

KING-GAGE® LP2

Tank Liquid Level

Inventory Monitoring

Process Integration

Multiple Tank Level Indicator

- 8 Tank Input Channels
- Dual Serial Communications Ports
- Nonvolatile Datapack iButton Memory
- Provides 24 Vdc Transmitter Excitation
- Operator Interface Keypad

The new LP2 Multiple Tank Indicator combines intelligent signal processing and data acquisition for seamless integration in process control. LP2 indicators will provide continuous measurement of liquid inventory in storage or processing tanks. Calculating level on the basis of hydrostatic pressure created by liquid depth, the system measures total product mass for more precise material accounting.

LP2 multiple tank indicators accept up to eight input channels that receive proportional 4-20 mA signals from liquid level transmitters. The actual sensor used to detect hydrostatic pressure (created by liquid depth) can be either electronic or pneumatic. With the latter, an electronic pressure transmitter is used to convert the sensor's pneumatic signal into 4-20 mA output (using a KING-GAGE® D/P Module or D/P Transmitter).

LP2 indicators express tank level directly in engineering units. The indicator references a capacity profile to correlate transmitter output to actual tank geometry. The indicator then formats the resulting value directly as the total weight or volume of liquid in the tank. As an operator interface, the keypad provides access to function selection and density adjustments. There are no user conversion factors involved or scaling points to enter. All application details are factory programmed into an innovative nonvolatile modular memory called the *Datapack iButton*.



**LP2™ Multiple Tank Indicator
with Operator Interface**

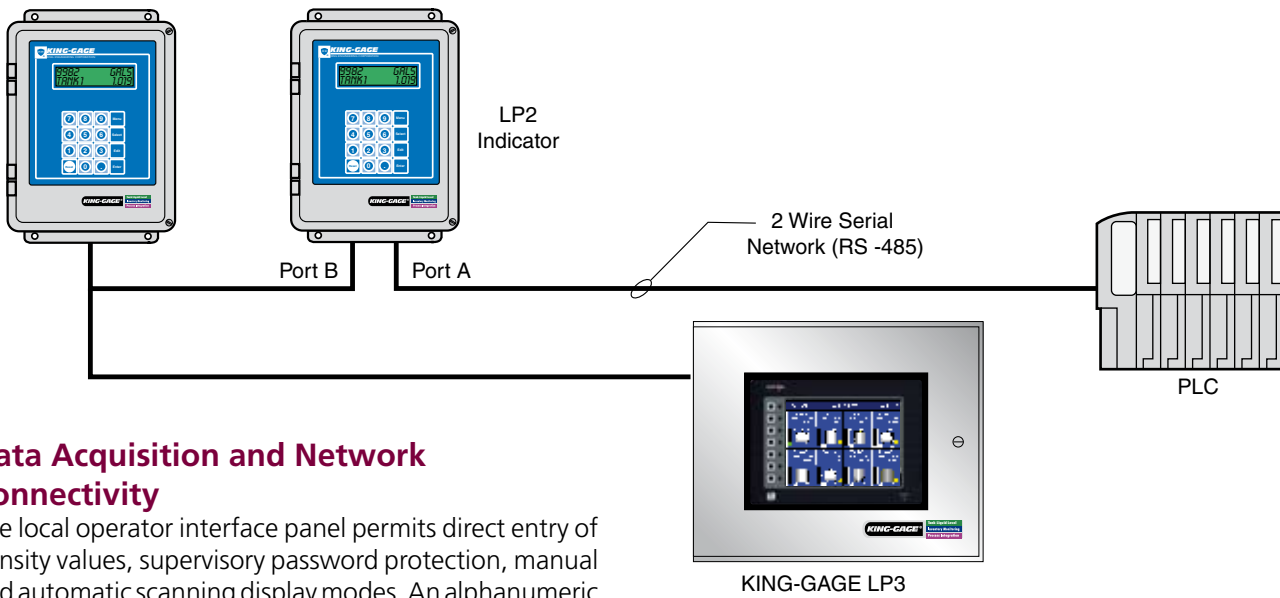

Data Acquisition and Network Connectivity

The local operator interface panel permits direct entry of density values, supervisory password protection, manual and automatic scanning display modes. An alphanumeric LCD panel provides 10-character tank identification with 8-digit display value and current density selection. Dual serial communications ports (RS-485) can be configured for different protocols such as master/satellite, ASCII data exchange or Modbus-RTU emulation. This flexibility means that LP2 indicators can be simultaneously linked to different data networks.

LP2 multiple tank indicators can be used to eliminate analog I/O at your PLC or PC-based control system. As data acquisition hubs, each LP2 tank level indicator provides multiple point serial communications. An expandable network of up to 32 discrete indicators can be installed on a single two wire network (RS-485) for total of 256 possible input channels.

Dual serial ports support multiple network configurations including query-response communications with a computer (or PLC), remote satellite displays or interface to a KING-GAGE LevelVIEW™ system.

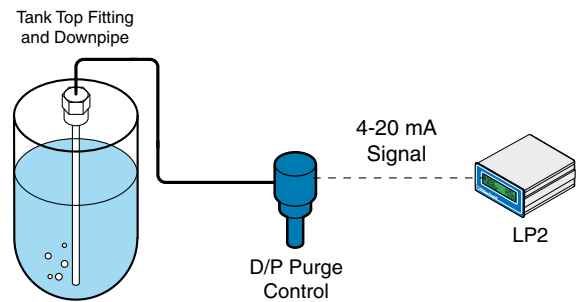
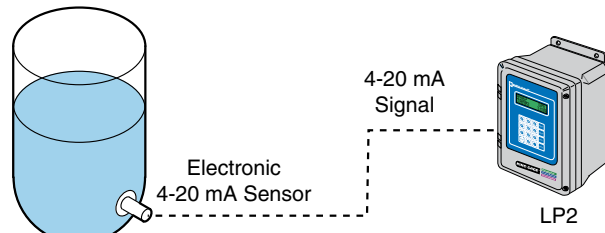

24 Vdc Output (Transmitter Excitation)

The LP2 tank indicator incorporates an internal 24 Vdc supply that can be used to power the signal loop. A pair of shunt/jumpers for each input channel are used to enable or disable this voltage supply across the signal input terminals. If an external power supply is used (occasionally tied through the I/O card of a PLC), the internal 24 Vdc can be easily disabled at the LP2.

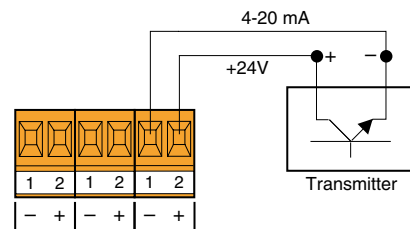

Transmitter Signal Loop
Onboard 24 Vdc Power Supply Enabled

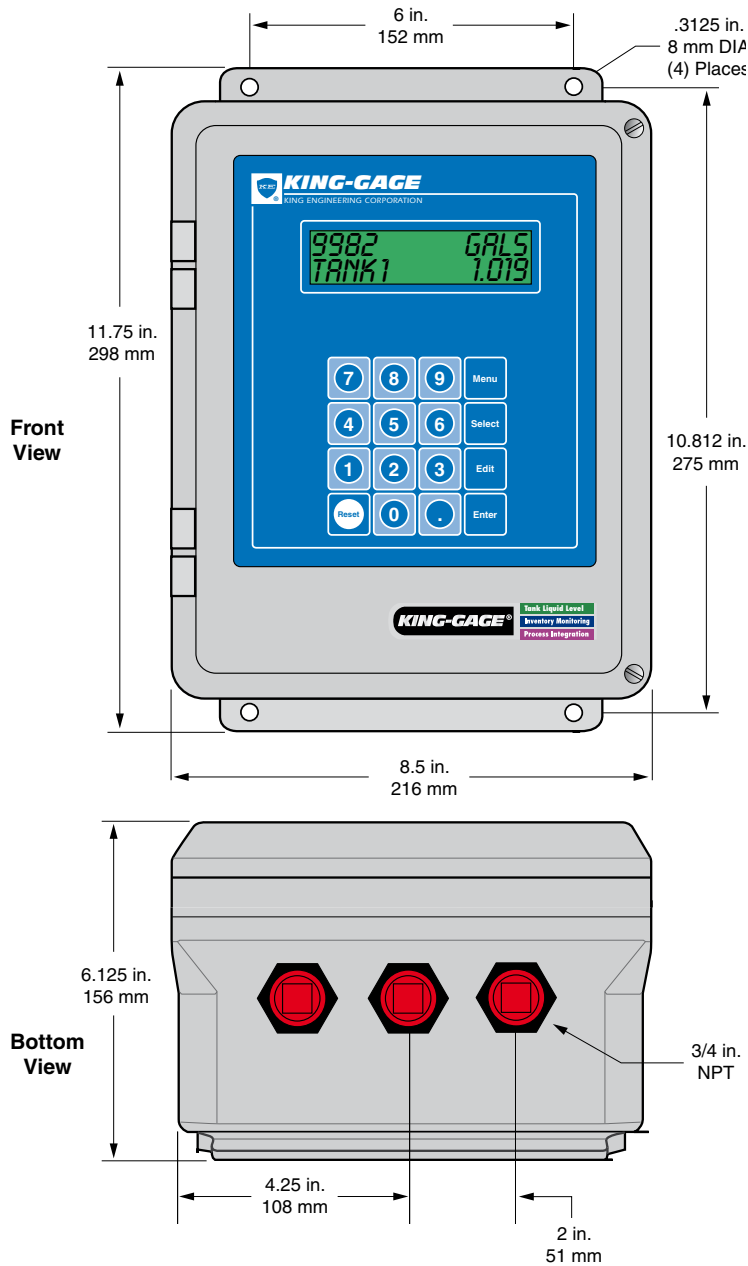

Specifications

Power Requirements

100-240 Vac, 50-60 Hz, 25 watts (fused internally for 2.5 A 120/250 V)

Temperature Range (Environmental)
30°F to 120°F (0°C to 50°C) operating range

Signal Input

4-20 milliampères (mAdc)

Input Channels

8 input channels; two wire 4-20 mA analog signal

Keypad

Membrane numeric keypad, five (5) function keys, positive tactile response

Power Output

24 Vdc nominal; fused @ 0.5 Amp

Input Impedance

 (Resistance)

120 ohm nominal (2.4 Vdc drop @ 20 mAdc)

Memory

Nonvolatile 64kbit memory iButton*

Digital Readout

Alphanumeric 0.3173 in. (8 mm) 16-character x 2-line LCD; numeric 8-digit (0-99999999 maximum)

Accuracy

±0.048% FS (±0.024% FS, typical)

Resolution

±0.024% FS maximum (±0.004 mA)

Communications

Two (2) serial EIA RS-485 ports; two wire multidrop

Enclosures

Shown: Engineered thermoplastic (NORYL) enclosure; UL 50, NEMA type 3, 3S, 4, 4X, 12; hinged cover with dual latching screws.

Optional: 14 gauge stainless steel enclosure; UL 50 type 4, 4X, 12, 13; hinged cover with dual latching screw lugs.

Application Programming

The LP2 indicator references a capacity profile to correlate transmitter output to actual tank geometry. This profile plus additional application details are factory programmed into an innovative nonvolatile Datapack iButton memory module. Different units of measurement and/or specific gravity values can be assigned to each tank in the system. LP2 stores all the user selections in its Datapack iButton memory. The more critical data is restricted to read only access to prevent any possible corruption of the original factory programming.

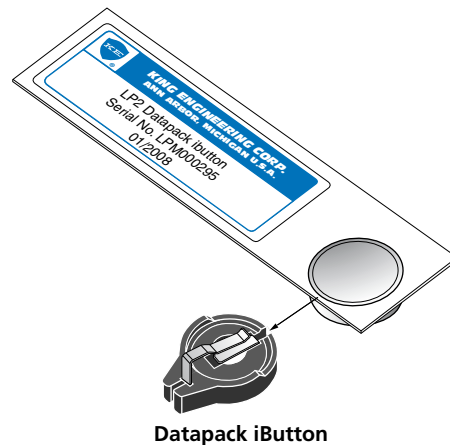

Datapack iButton

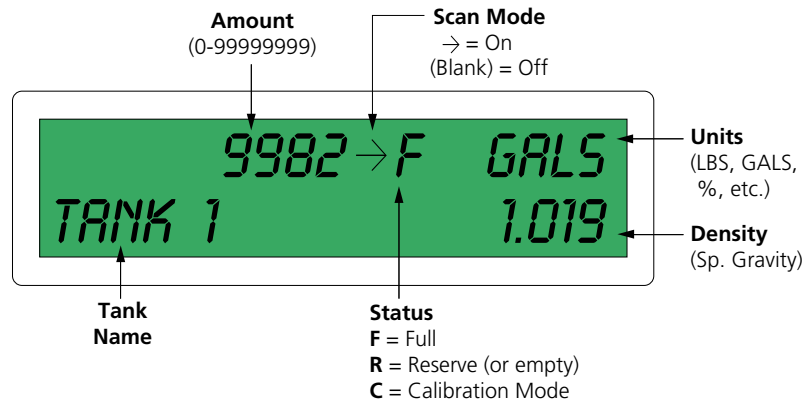

Operator Interface and Menu Selections

You can view tank input channels either by scanning or random access. Press the desired channel number directly to view tank level. To continue viewing tank channels in sequential order, simply press SELECT to view the next channel. Holding the key down for 3-seconds initiates the auto scroll mode for all tank channels. Press any key to restore normal single channel display mode.

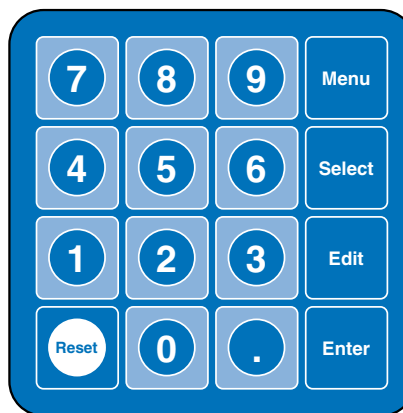

The user interface of the LP2 is extremely easy to operate. Simply press the MENU key to cycle through options such as Display Unit selection, Specific Gravity input, Calibration mode and Password Access (to restrict specific gravity entry).

LP2 indicators can be used as basic stand alone tank level indication. Combining both accuracy and reliability, they provide a complete tank level gauging solution where precise accounting of liquid inventory is needed. LP2 indicators also simplify future upgrades requiring system interconnectivity for industrial networks.

Menu Display Modes

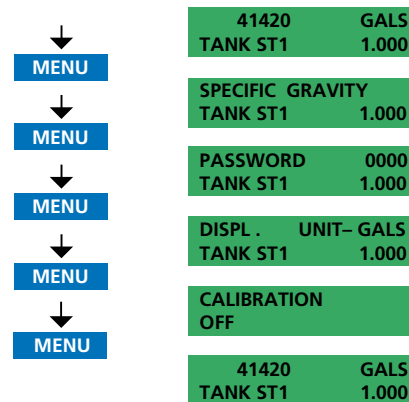

* iButton is a trademark of Dallas Semiconductor.

© KING-GAGE and the KE emblem are registered trademarks and LP2 is a trademark of King Engineering Corp.

© 2008 King Engineering Corporation. All rights reserved.
Specifications subject to change without notice.



3201 South State, Ann Arbor, Michigan 48108 U.S.A.
PO Box 1228, Ann Arbor, Michigan 48106-1228
Phone: 734-662-5691 ■ FAX: 734-662-6652
www.king-gage.com