

# LevelPRO SP™

## Multiple Tank Level Processor & Digital Setpoint Control

- 8 Tank Multiple Input Capacity
- Operator Interface Keypad
- Digital Setpoint SPDT Relays
- Provides 24 Vdc Transmitter Excitation
- Dual Serial Communications Ports

The new **LevelPRO SP** processor provides continuous measurement of liquid inventory in storage or processing tanks. Calculating level on the basis of hydrostatic pressure created by liquid depth, the system measures total product mass for more precise material accounting.

A full numeric keypad and function keys support various user selections, including direct entry of control setpoints (high or low level) for each tank. The two line alphanumeric LCD readout shows tank level, readout unit (user selective), tank name and specific gravity in the normal display mode.

### Digital Setpoint Control

The added functionality of digital setpoint control offers a complete level monitoring and simplified process control solution for the user. Setpoints are easily entered as volume, weight or percent full values for consistent and accurate process triggers such as pump control or other on/off functions.

LevelPRO SP includes a display panel to visually confirm setpoint actuations for each tank. Personnel can easily monitor level setpoint status of any or all tanks in the system at a glance.



LevelPRO™ SP Multiple Tank Processor  
with Setpoint Status Display

## LevelPRO SP Operator Interface

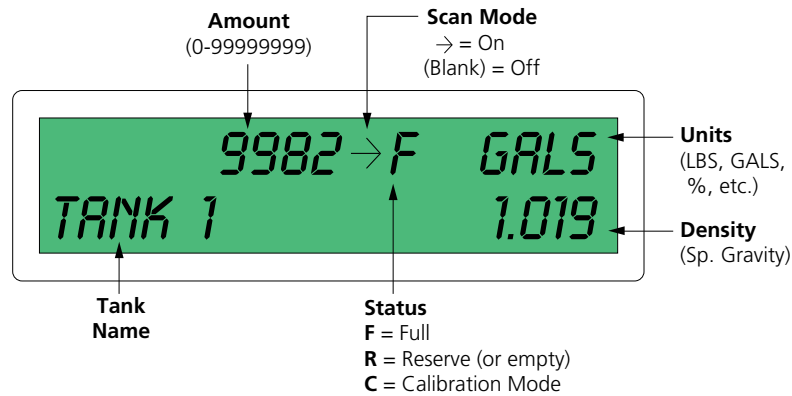

You can view tank input channels either by scanning or random access. Press the desired channel number directly to view tank level. To continue viewing tank channels in sequential order, simply press SELECT to view the next channel. Holding the key down for 3-seconds initiates the auto scan mode for all tank channels. Press any key to restore normal single channel display mode.

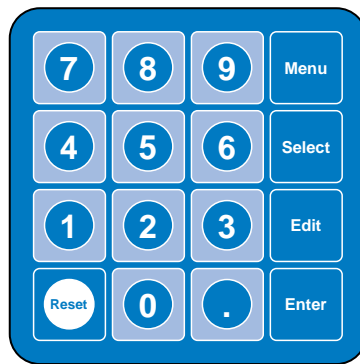

Entering setpoints is as simple as choosing the tank channel and following the menu selections until SET# 1 or SET# 2 appears. Press the EDIT key and directly enter the level value for the setpoint. This value is stored in nonvolatile memory and will be automatically compensated for any later changes in specific gravity.

The user interface of the LevelPRO is extremely easy to operate. Simply press the MENU key to cycle through options such as Display Unit selection, Specific Gravity input, Calibration mode, Setpoints input and Password Access (to restrict specific gravity entry).

The LevelPRO SP provides the user with two (2) fully independent SPDT relays per tank input channel. The configuration includes normally-open (NO), normally-closed (NC) and common (C) relay contacts. Factory programming options include standard LOW-HIGH (descending/ascending) or HIGH-HIGH (ascending/ascending) setpoint actuation.

### Menu Display Modes

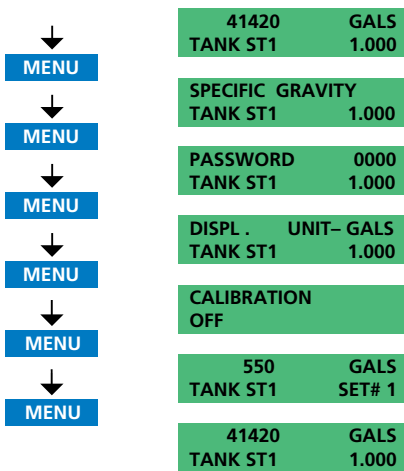

### Tank Setpoint Editing

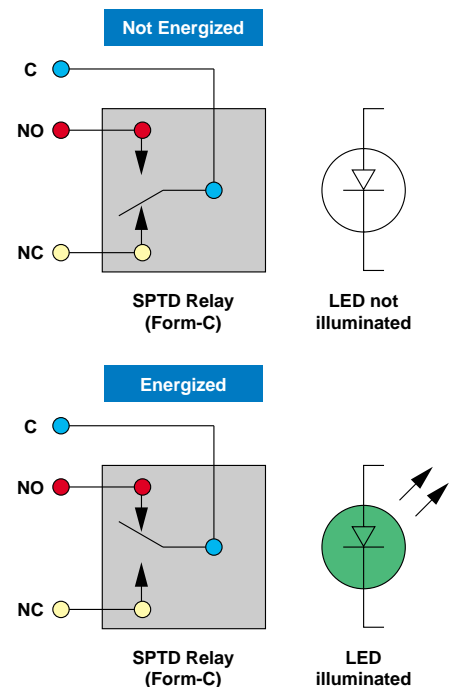
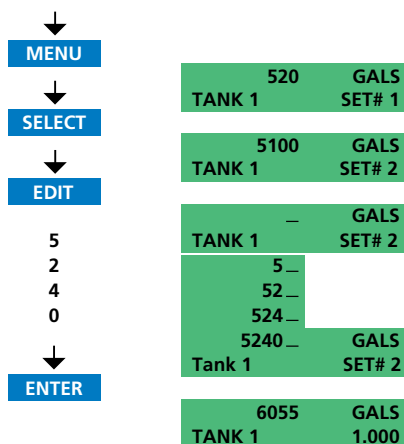

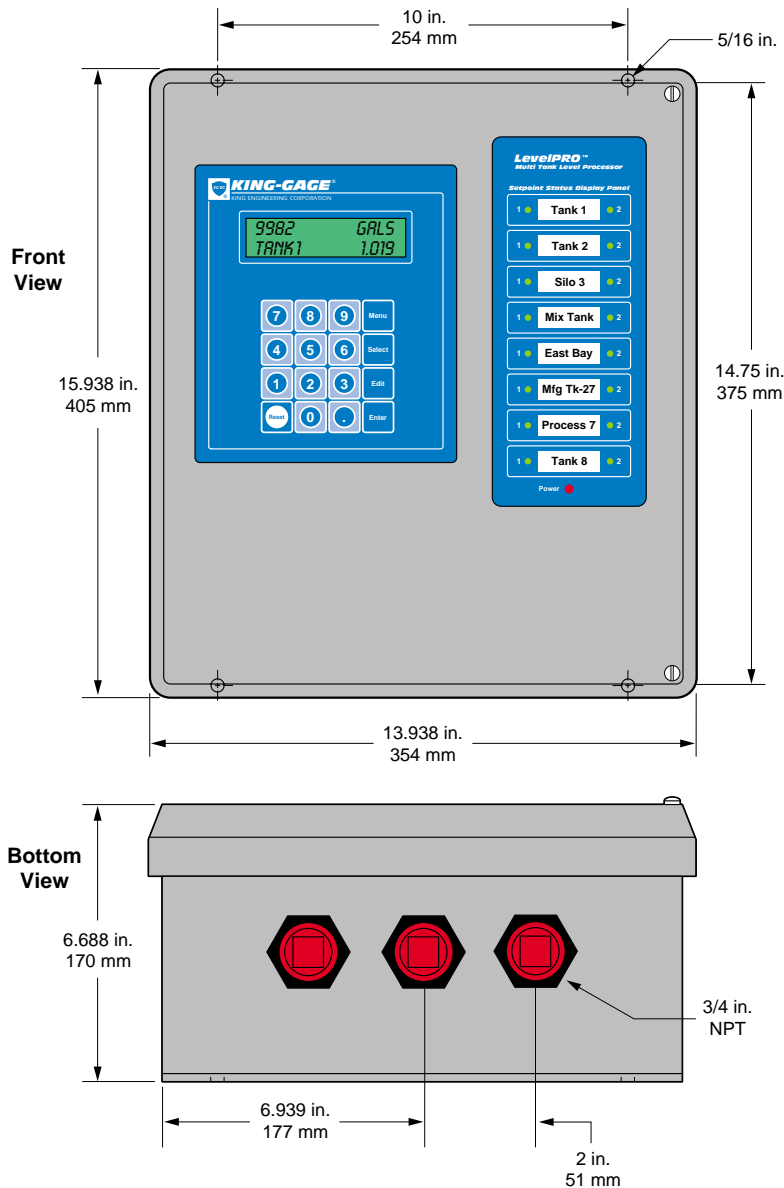

## Application Programming

The LevelPRO processor references a capacity profile to correlate transmitter output to actual tank geometry. The processor then formats the resulting value directly as the total weight or volume of liquid in the tank. This profile plus additional application details are factory programmed into an innovative nonvolatile **Datapack iButton\*** memory module. Different units of measurement and/or specific gravity values can be assigned to each tank in the system. LevelPRO stores all the user selections in its Datapack iButton memory. The more critical data is restricted to read only access to prevent any possible corruption of the original factory programming.

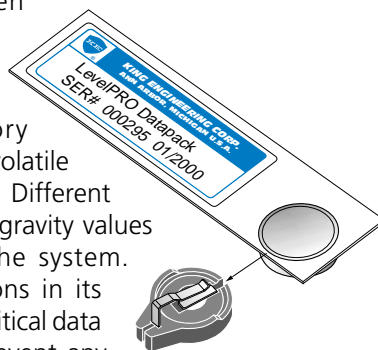

## Specifications

- Power Requirements**  
 100-240 Vac, 50-60 Hz, 25 watts (fused internally for 2.5 A 120/250 V)
  - Temperature Range** (Environmental)  
 30°F to 120°F (-1°C to 49°C) operating range
  - Signal Input**  
 4-20 milliampères (mA<sub>dc</sub>)
  - Input Channels**  
 8 input channels; two wire 4-20 mA analog signal
  - Keypad**  
 Membrane numeric keypad, five (5) function keys, positive tactile response
  - Power Output**  
 24 Vdc nominal; fused @ 0.5 Amp
  - Input Impedance** (Resistance)  
 120 ohm nominal (2.4 Vdc drop @ 20 mA<sub>dc</sub>)
  - Memory**  
 Nonvolatile 64kbit memory iButton
  - Digital Readout**  
 Alphanumeric 0.3173 in. (8 mm) 16-character x 2-line LCD; numeric 8-digit (0-99999999 maximum)
  - Accuracy**  
 ±0.048% FS (±0.024% FS, typical)
  - Resolution**  
 ±0.024% FS maximum (±0.004 mA)
  - Communications**  
 Two (2) serial EIA-485 ports; two wire multidrop
  - Setpoint Relays**  
 Sixteen (16) independent user setpoints; two (2) setpoints per tank channel; SPDT (form-C) relays; maximum 3.0 A @ 115 Vac. Rated for minimum 100,000 cycle/life at rated load.; continuously adjustable over full input range.
  - Status Display Panel**  
 LED setpoint indicators for visual confirmation when individual SPDT relays are energized.
  - Housing**  
 Fiberglass-reinforced polyester (FRP) enclosure; U.L. listed (U.L. 508) types 3, 3R, 3S, 4, 4X, and 12.
- Not Shown:** Optional stainless steel (type 304) enclosure; overall maximum dimensions 15-1/2" H x 13" W x 6" D.

# LevelPRO SP™

## Data Acquisition and Network Connectivity

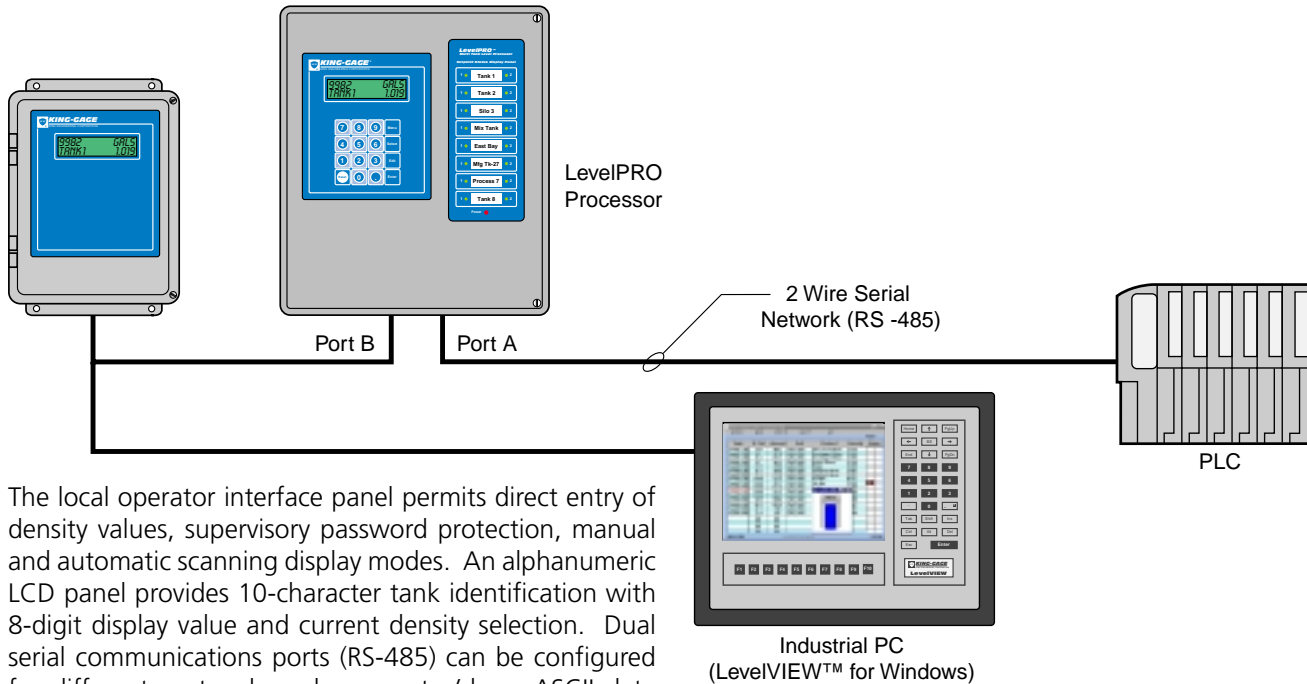

The local operator interface panel permits direct entry of density values, supervisory password protection, manual and automatic scanning display modes. An alphanumeric LCD panel provides 10-character tank identification with 8-digit display value and current density selection. Dual serial communications ports (RS-485) can be configured for different protocols such as master/slave, ASCII data exchange or Modbus-RTU emulation. This flexibility means that LevelPRO processors can be simultaneously linked to different data networks.

## Input Requirements

LevelPRO multiple tank processors accept up to eight input channels that receive proportional 4-20 mA signals from liquid level transmitters. The actual sensor used to detect hydrostatic pressure (created by liquid depth) can be either electronic or pneumatic. With the latter, an electronic pressure transmitter is used to convert the sensor's pneumatic signal into 4-20 mA output (using a KING-GAGE® D/P Module or D/P Transmitter).

The LevelPRO tank processor incorporates an internal 24 Vdc supply that can be used to power the signal loop. The voltage supply can be set as enabled or disabled for each individual signal input channel. This can be done to accommodate an external power supply (occasionally tied through the I/O card of a PLC).

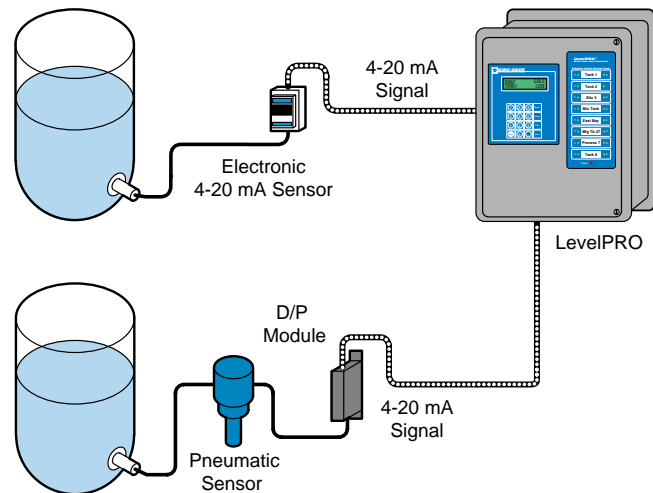

© KING-GAGE and the KE emblem are registered trademarks and LevelPRO SP is a trademark of King Engineering Corp.

\* iButton is a trademark of Dallas Semiconductor.

Specifications subject to change without notice.