

# **KING-GAGE®**

## **4-20 mA Liquid Level Transmitter**

### **LevelTRAN**

Liquid Level Transmitter  
Model 541\*-1-\* w/Cable  
and Junction Enclosure

Installation and Operation  
Instructions



© 2002 King Engineering Corporation. All rights reserved.

The information contained in this manual was accurate at the time of release. Specifications are subject to change without notice.

**Warranty** - All King Engineering products are guaranteed to be free from defects in material and workmanship for one year from the date of purchase. Any product or part found to be defective under normal use within one year of purchase will be repaired or replaced at no charge if returned to the company at Ann Arbor, Michigan within ten days of discovery of the defect. No other warranties, whether expressed, implied or statutory, including the warranties of fitness for a particular purpose or merchantability, are given by this agreement.

The exclusive remedy for nonconformity of these goods shall be repair and/or replacement of the nonconforming goods or parts.

Seller will not be liable for consequential damages resulting from breach of this agreement. The term "consequential damages" shall include but shall not be limited to damage to all machines, equipment and goods other than the goods sold hereby, interruption of production, loss of profits, delays of any kind, administrative expense and overhead.

#### **Revisions:**

- (A) May 2001 – Beta Release
- (B) June 2001 – Beta Release w/ Flex Conduit
- (C) October 2001 – Production release (LevelTRAN)
- (D) November 2001 - Replacement part numbers p. 9
- (E) January 2002 - Model No. Revised (cover page)

### KING-GAGE LevelTRAN Level Transmitter

Two-wire sensor/transmitter provides a direct 4-20 mAdc analog electronic output signal. Fixed-range transmitter is designed specifically for hydrostatic pressure measurement for liquid level gauging.

Transmitter package includes 15 feet of cable and corrosion-resistant Signal Junction Enclosure. (This enclosure also houses the external zero adjustments and signal loop connection terminals.)

### Range Designation

A model number/range designation is listed on the end of the transmitter housing. The last two digits of the model number actually refer to the transmitter range. As an example, MODEL 5411-1-10 is a 0-10 psig range transmitter.

### Model No. Designations

541x-1-xx

Pressure Range	
05	..... 0-5 psig
10	..... 0-10 psig
15	..... 0-15 psig
30	..... 0-30 psig
50	..... 0-50 psig

Configuration (Housing)	
1	..... Standard Length
2	..... Long Length

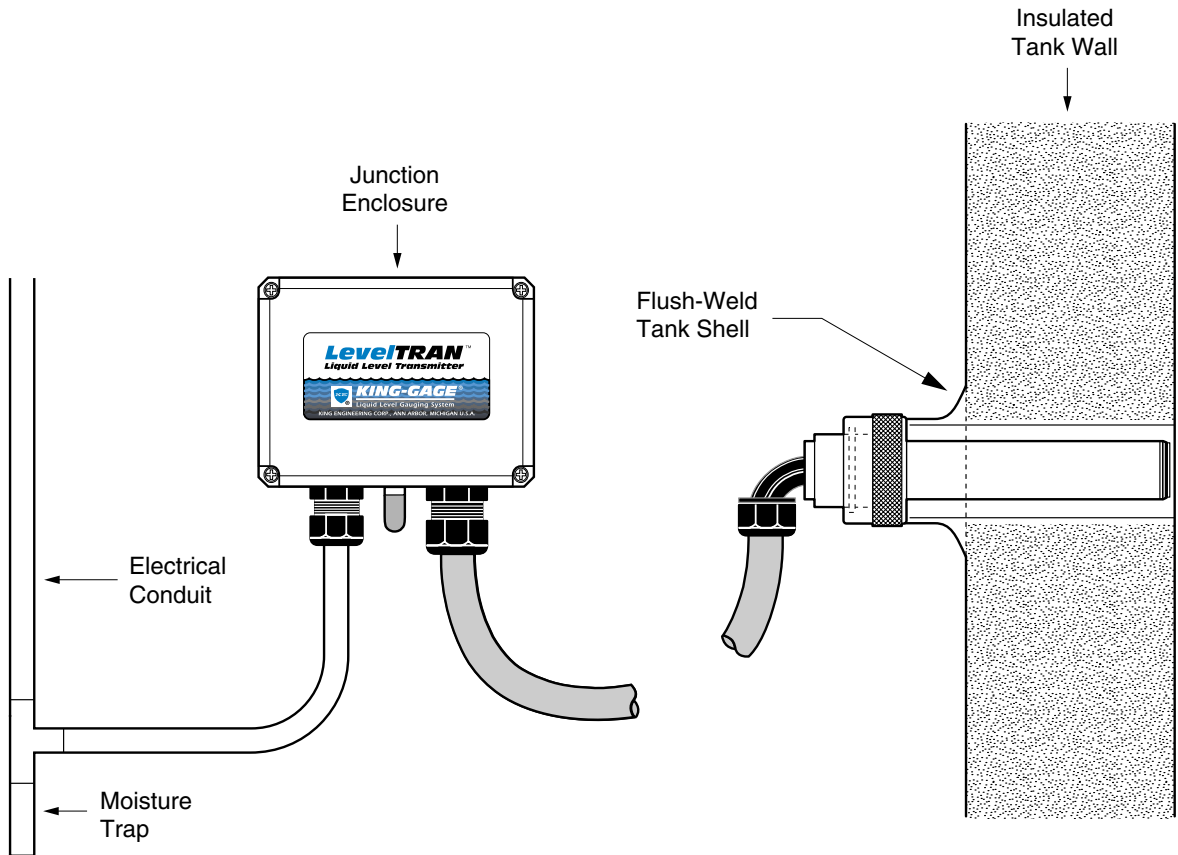

## Mounting Supplied Junction Enclosure

This corrosion resistant non-metallic enclosure houses the zero adjustment and serves as the signal terminal connections for the transmitter. The supplied transmitter cable must terminate within the enclosure to maintain the atmospheric reference vent integrity. Do not mount enclosure beyond what the supplied cable length will allow — DO NOT SPLICE additional cable onto the transmitter.

The enclosure is designed to accept four (4) mounting screws (not supplied). Refer to the illustration on page 7.

**Enclosure Vent** - a vent plug is furnished installed into the bottom of the Junction Enclosure. A polypropylene breathable shield prevents infiltration of moisture into the enclosure. Do not plug or paint over this vent element.

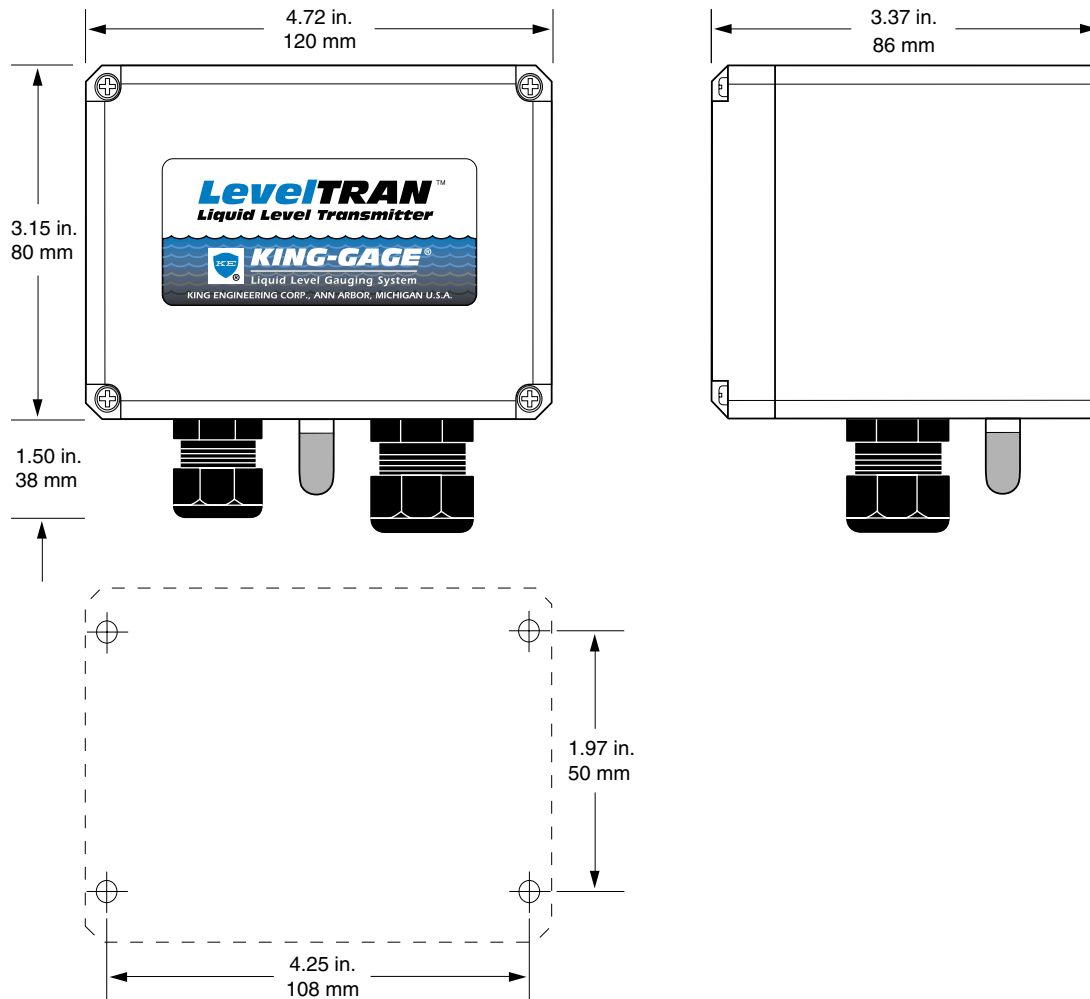

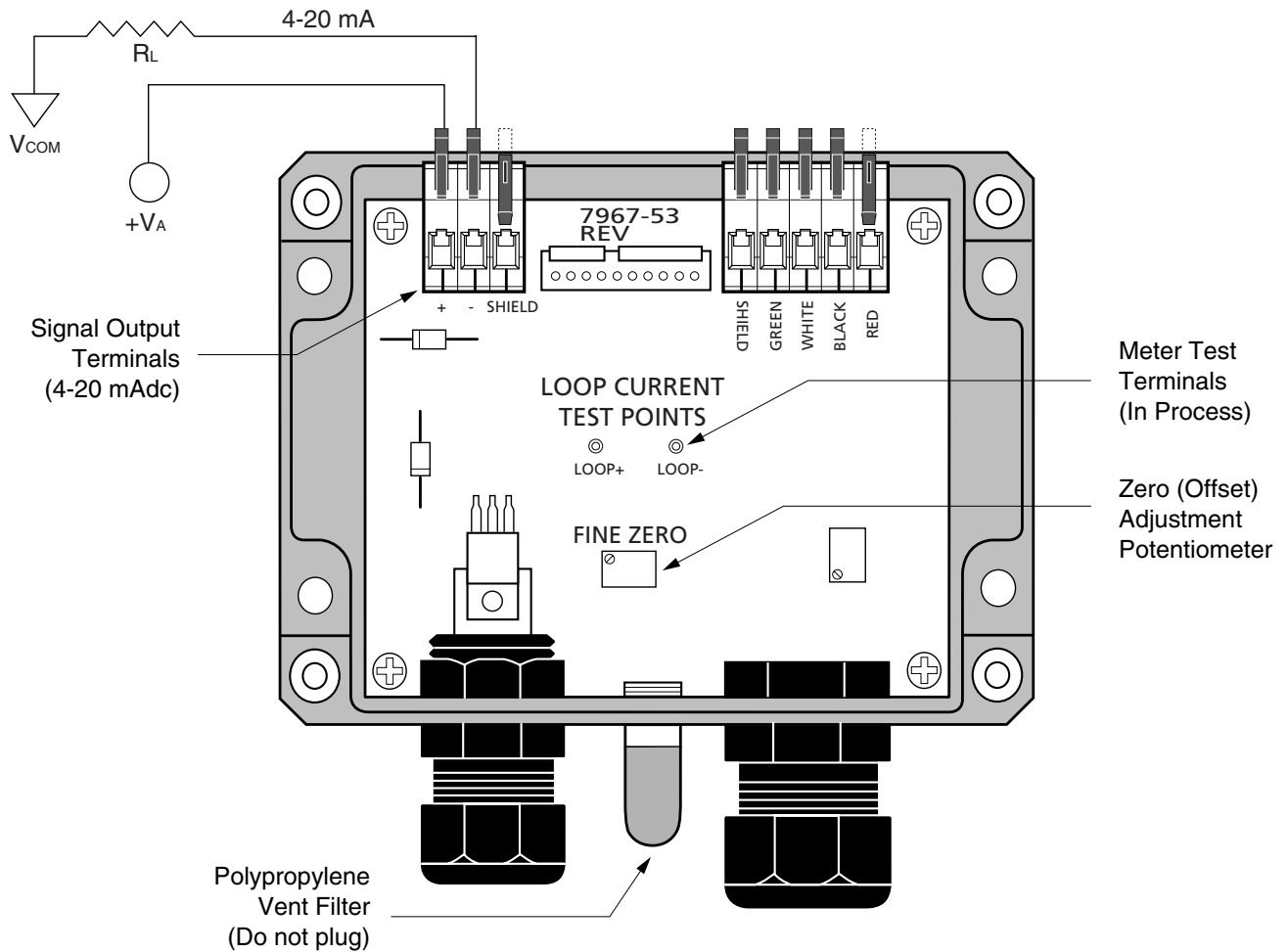

Interior View - Junction Enclosure

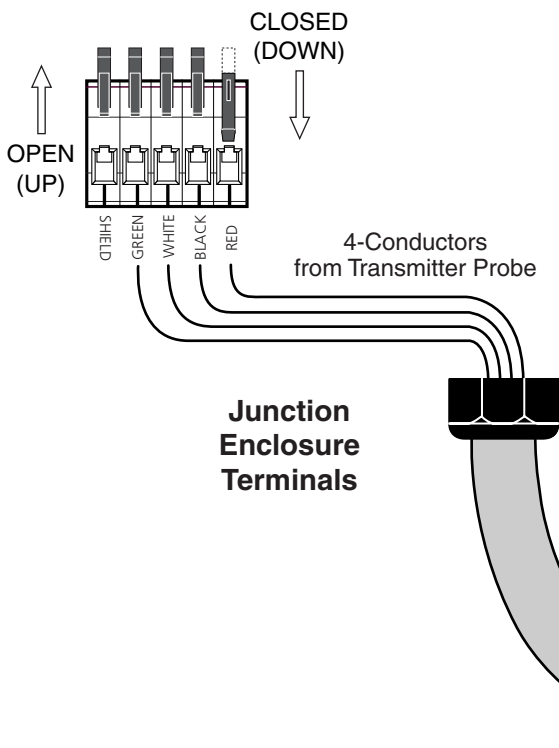

**Sensor Cable**

The transmitter cable contains four (4) individual color coded wires plus shield that are to be terminated within the junction enclosure. Follow color code as noted on the circuit board contained inside the enclosure.

This integral cable maintains the necessary atmospheric reference vent for the sensor. It must be terminated within the supplied vented enclosure. A water-tight plastic connector seals the sensor cable at the bottom of the junction enclosure.

### Power Requirement

The LevelTRAN transmitter requires a source of DC power for operation. Minimum excitation voltage must be no less than 18 VDC. Any receiver installed on the signal loop (meters, data loggers, controllers, etc.) must be taken into account when determining the required power supply voltage to be used. The internal resistance of each device added together represents the total "load" residing on the signal loop circuit.

$$\text{Load Capacity} = \frac{(\text{Supply Voltage} - 18)}{(\text{OHMS})} \times .02$$

### Load Capacity at Supplied Voltage

20 Vdc	24Vdc	28Vdc	32Vdc
100 ohms	300 ohms	500 ohms	700 ohms

KING-GAGE® tank processors and LevelBAR provide 24 Vdc excitation to power the signal loop circuit. (If the application requirement exceeds 300-ohms, an external power supply of appropriate voltage will be required.)

### Signal Cabling

The 4-20 mA signal loop needs to be run using twisted pair (two conductor) cable. "Noise" or EMI (electromagnetic interference) does not generally create a problem since it is common to both wires in the pair and essentially cancels itself out. In most applications, non-shielded twisted pair instrumentation cable (20-22 AWG) will be suitable for the signal loop between the LevelPRO and sensor/transmitter.

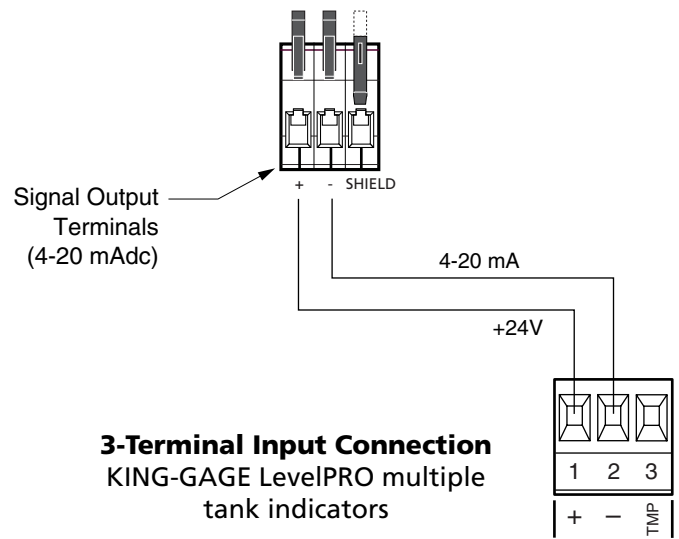
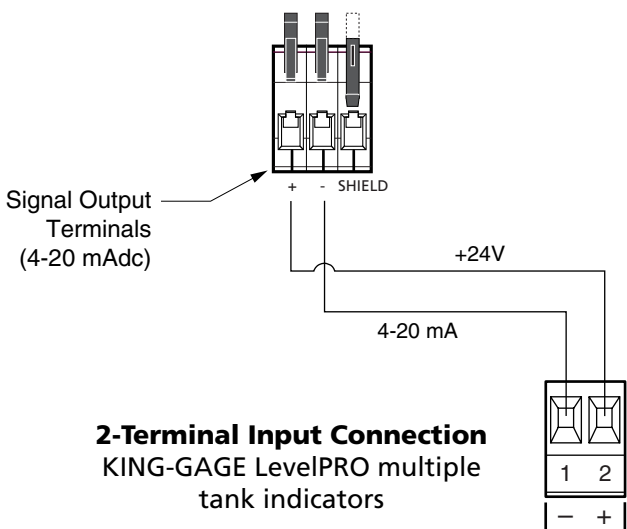
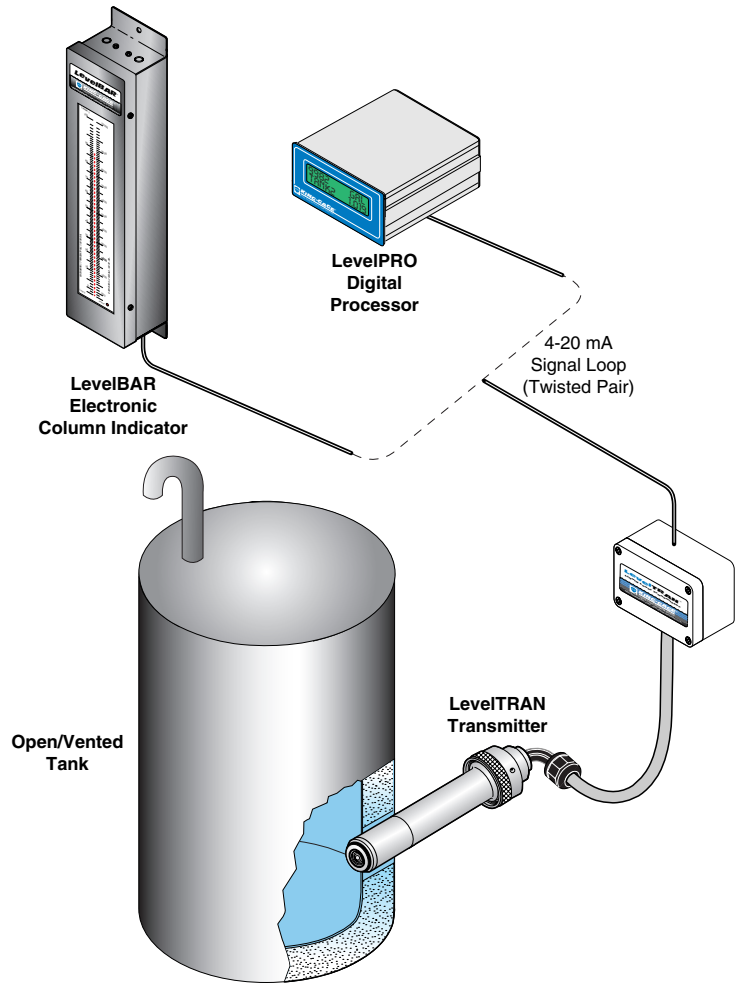

Detail - Mounting Junction Enclosure

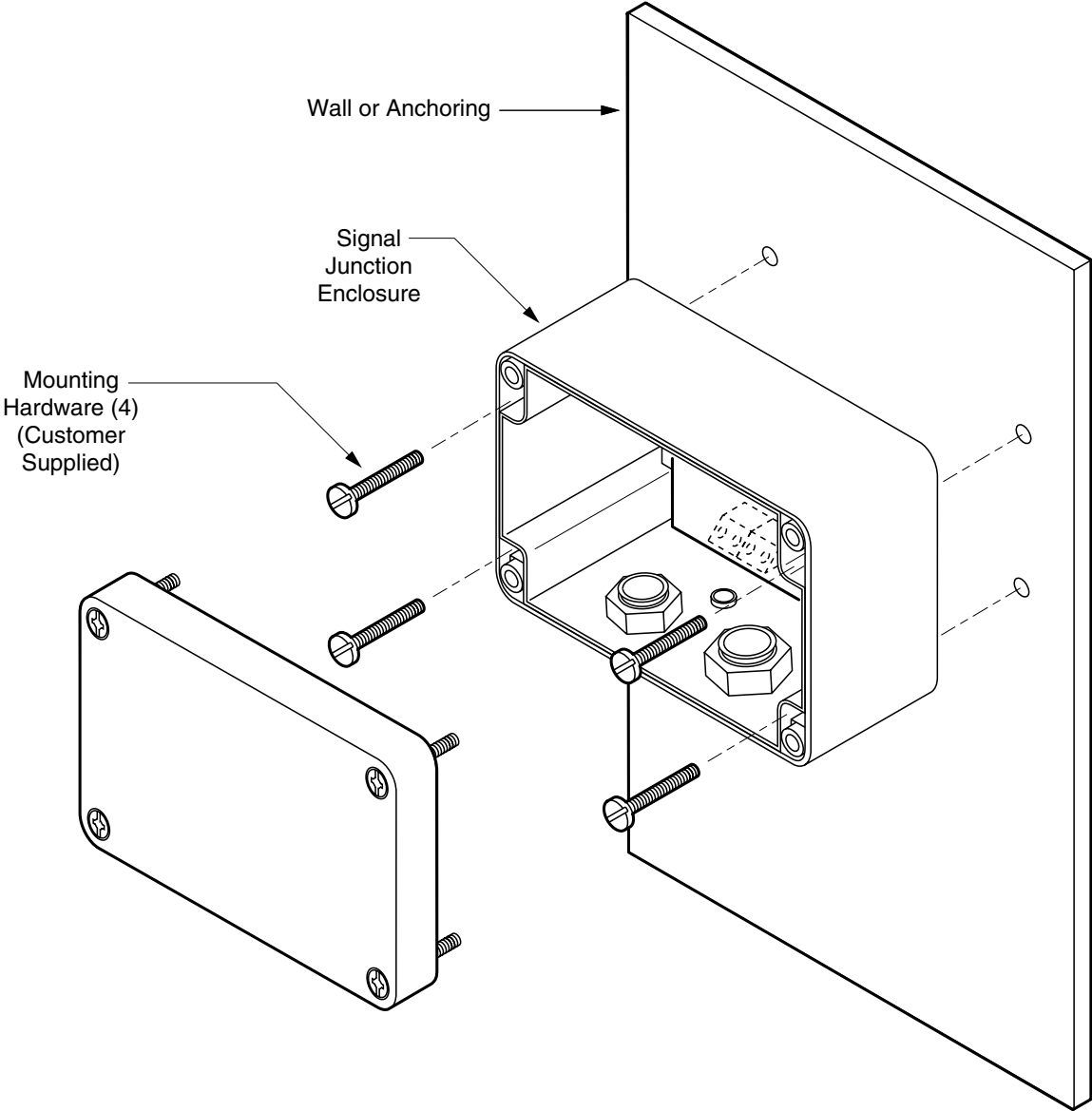

### Transmitter Adjustments

The LevelTRAN transmitter provides for the zero (trim) adjustment to be made within the signal junction enclosure. Test meter connections are also located within the enclosure making for simplified in-process monitoring by maintenance or operating personnel.

#### Zero Adjustment

Some adjustment of the transmitter "zero" setting may be periodically required. It is generally recommended that the zero output be checked at least every 12 months.

### In-Process Monitoring

The milliamp output signal (4-20 mA<sub>dc</sub>) can be checked while the transmitter is installed at the tank. Test meter terminals are provided within the Signal Junction Enclosure (see previous page) that permit accurate reading without disturbing the signal loop wiring.

**Important!** Set meter for DC current, mA or .001 Amp scale. Internal resistance through the meter must be 20 ohms or less. Higher resistance values will erroneously show lower milliamp reading on meter.

**Note:** Always re-install cover when done.

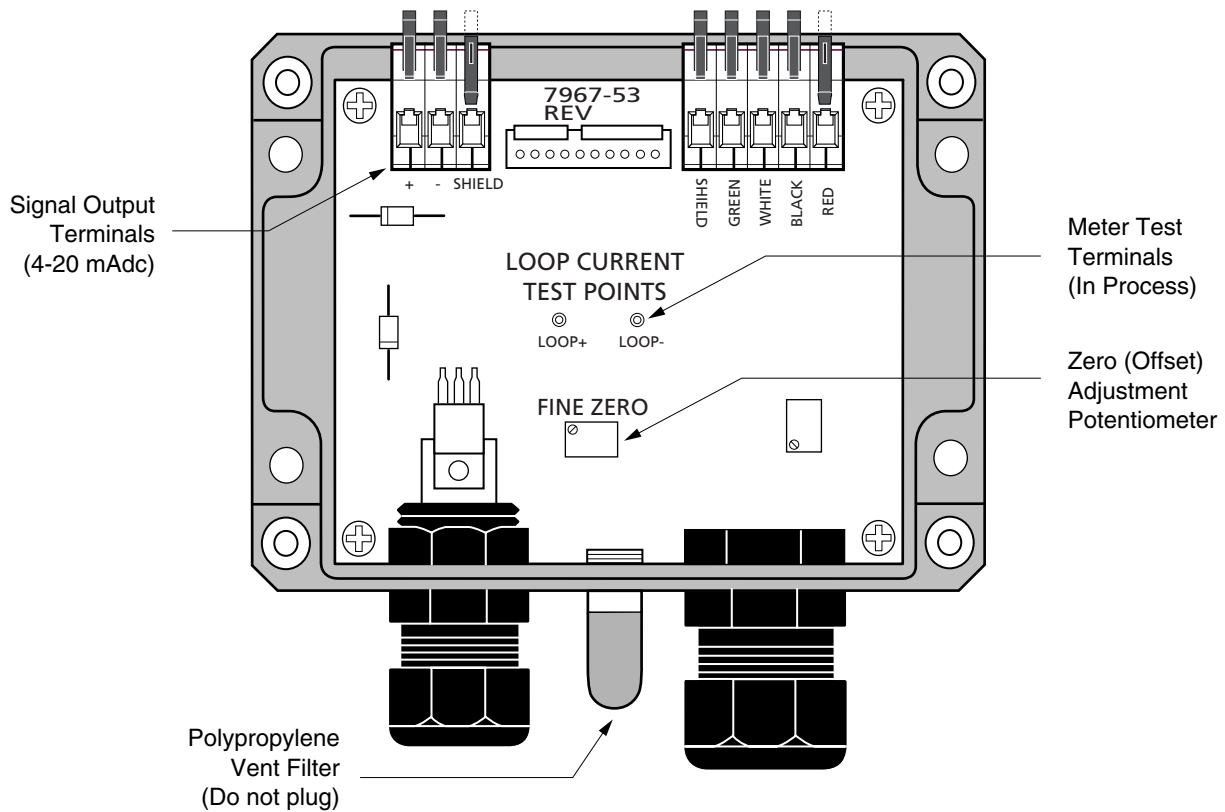

Span Adjustment/Test Meter Location - Signal Junction Enclosure

# Replacement and Maintenance Procedures

## Replacing Sensing Element Assembly

The transmitter's sensing element can be replaced in the unlikely event it becomes physically damaged. This element is available as a sub-assembly including O-ring seals (as shown). To remove, simply pull the element out of the transmitter housing, separate the wiring connector and disconnect the vent tube. To install the replacement element, connect the wiring and secure the vent tube before inserting the assembly into the transmitter housing.

## O-Ring Seals

The outer O-ring at the head of the sensing element forms the critical seal at the tank mounting and should be replaced if there are signs of physical damage (such as a cut). If replacement seal is needed, refer to the part number called out in the illustration.

The inner O-ring that seal the sensing element within housing are generally protected and should not require replacement. Part numbers are shown for reference only.

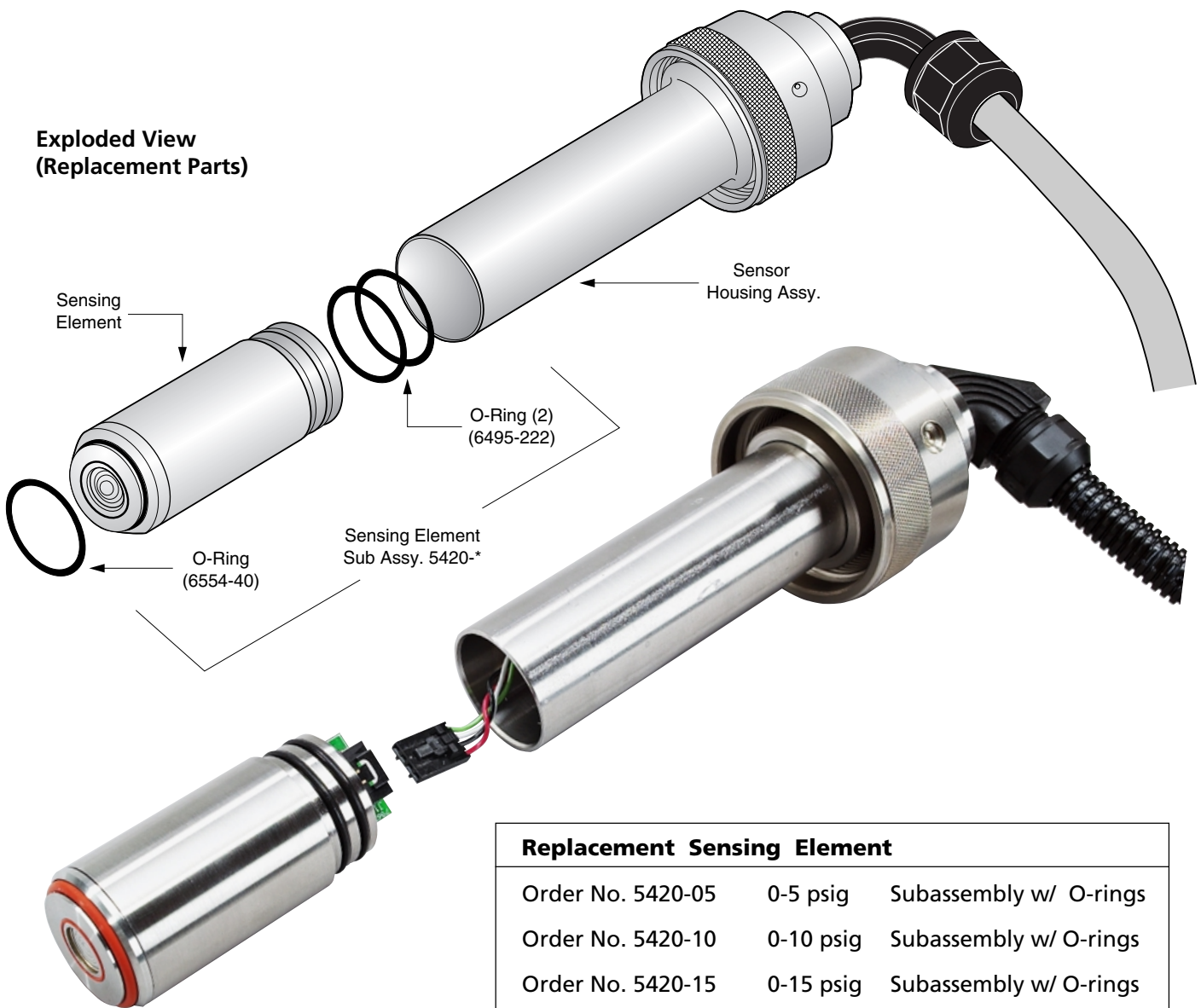

Replacement Sensing Element		
Order No. 5420-05	0-5 psig	Subassembly w/ O-rings
Order No. 5420-10	0-10 psig	Subassembly w/ O-rings
Order No. 5420-15	0-15 psig	Subassembly w/ O-rings
Order No. 5420-30	0-30 psig	Subassembly w/ O-rings
Order No. 5420-50	0-50 psig	Subassembly w/ O-rings

## Calculating Milliamp Output

The King-Gage Electronic Sensor is factory-calibrated to nominal range only. Since there is no appreciable degree of span adjustment, the milliamp output of the sensor at full tank level will generally be less than 20.00 mA.

Actual output can be calculated based on total tank depth and specific gravity of the liquid product:

$$\frac{(B - A) \times C}{27.6807} = \text{Tank Pressure}$$

where ...

- A** = Reserve (inches of depth from low point of tank to sensor)
- B** = Full Tank (inches of depth from low point of tank to full)
- C** = Specific Gravity of Tank Contents

Now, using the calculated tank pressure from above, the actual milliamp value at full can be determined:

$$\frac{(16 \times \text{Tank Pressure}) + 4}{\text{NOMINAL psig RANGE}} = \text{mA Output}$$

## Example - mA Output Calculation for Tank Gauging Application

The following example shows how the milliamp output of the sensor at full tank can be calculated. The "Reserve" represents the distance from the lowest point on the bottom of the tank to the installed sensor. "Full" is the level of contents at which the tank is filled to capacity. The liquid contents of the tank is milk @ 1.032 sp.gr. The sensor installed is a nominal 15 psig range model.

**C** = 1.032 (specific gravity)

**B** = 400 in. (full level)

**A** = 28 in. (reserve)

$$\frac{(400 - 28) \times 1.032}{27.6807} = 13.87 \text{ psig}$$

$$\frac{(16 \times 13.87) + 4}{15 \text{ PSIG}} = 18.79 \text{ mA}$$

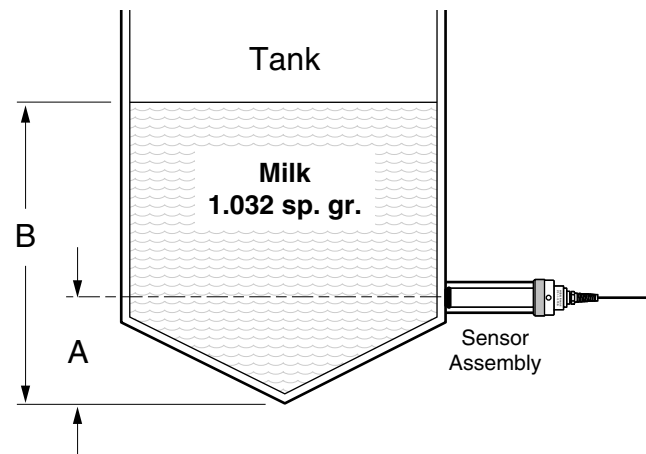

3201 South State St, Ann Arbor, Michigan 48108-1625 U.S.A.  
PO Box 1228, Ann Arbor, Michigan 48106-1228 U.S.A.  
Phone: (734) 662-5691 ■ FAX: (734) 662-6652