

**AcraSensor Diaphragm Sensing Unit Assy**  
Part No. 8999-\*\*-4

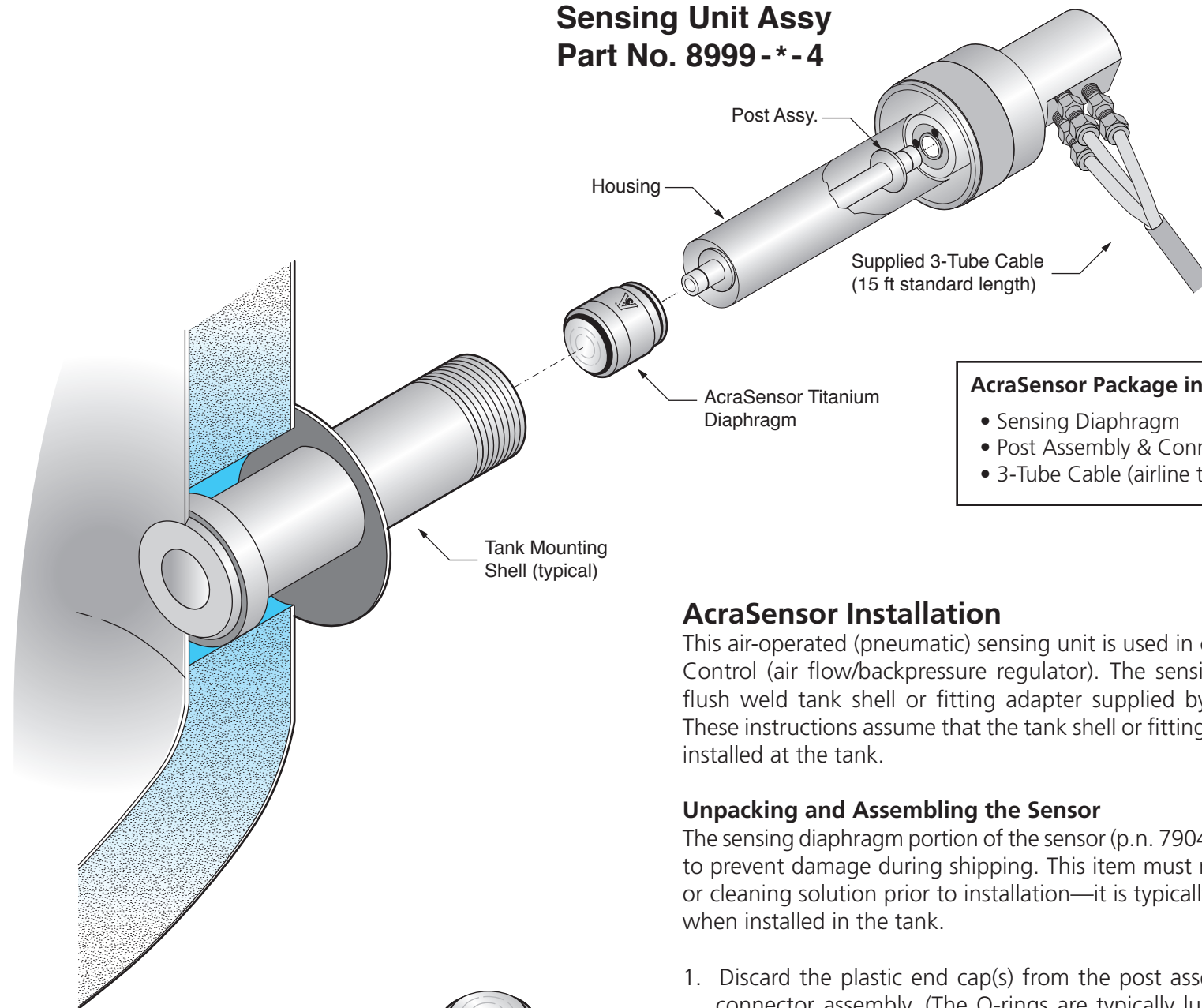

- AcraSensor Package includes:**
- Sensing Diaphragm
  - Post Assembly & Connector Assembly
  - 3-Tube Cable (airline tubing)

**AcraSensor Installation**

This air-operated (pneumatic) sensing unit is used in conjunction with a Sensor Control (air flow/backpressure regulator). The sensing unit mounts within a flush weld tank shell or fitting adapter supplied by King Engineering Corp. These instructions assume that the tank shell or fitting adapter has already been installed at the tank.

**Unpacking and Assembling the Sensor**

The sensing diaphragm portion of the sensor (p.n. 7904-1) is packaged separately to prevent damage during shipping. This item must not be immersed in water or cleaning solution prior to installation—it is typically cleaned by the CIP cycle when installed in the tank.

1. Discard the plastic end cap(s) from the post assembly and insert into the connector assembly. (The O-rings are typically lubricated at the factory to ease assembly—if necessary, apply an appropriate lubricant designed for O-ring seals.)
2. Remove the sensing diaphragm from the separate container. Grasp the outer edge of the assembly and avoid direct contact with the flexible face of the diaphragm. Push the diaphragm body onto the post assembly.
3. Carefully insert the assembly into the tank shell or adapter. Thread the end nut (of connector assembly) onto the end of the shell and hand tighten until adequately snug.



**AcraSensor Part Number Designation**

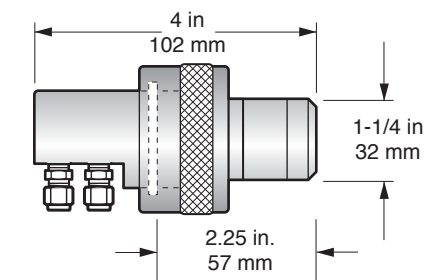

**Part No. 8999-1-4 (Short Mount)**  
For installation on non-insulated tanks with single wall construction.

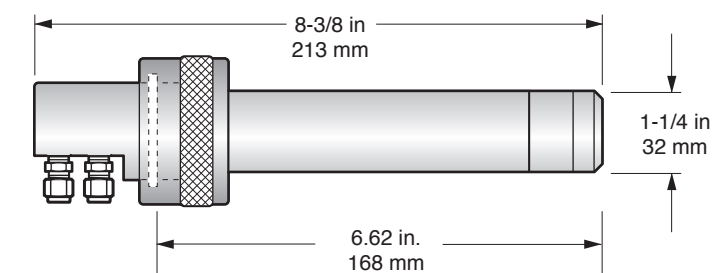

**Part No. 8999-2-4 (Standard Mount)**  
For insulated wall tanks up to 4-1/2 in. thick (or using "short" adapter).

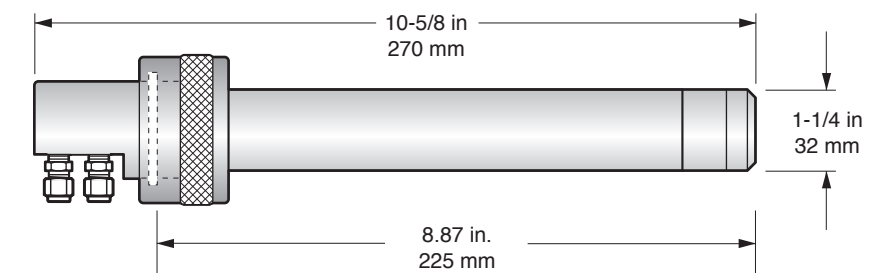

**Part No. 8999-3-4 (Long Mount)**  
For insulated wall tanks up to 6-3/4 in. thick (or using "standard" adapter).

**INSTALLATION INSTRUCTIONS**

**KING-GAGE®**  
**AcraSensor Pneumatic Tank Level Sensing Unit**

			DATE	10/01/2010
C	10/10	Assy. revised w/ sleeve	DRAWN BY	D.Kennedy
B	11/02	Revised and redrawn	APPROVED	



DWG. NO.	<b>K-1060-1-8999</b>
SHEET 1 OF 2	REV. <b>C</b>

## Tubing Connections

The AcraSensor package typically includes a length of 3-tube cable (15 ft standard length) for the airline connections. The cable should be used for the interconnections to the Sensor Control or D/P Sensor Control unit (refer to separate installation instructions for these items).

Refer to the illustrations provided that correspond to the applicable Sensor Control model.

3-tube cable is comprised of individual 1/4" tubes wrapped by a PVC protective sheath. Interconnections between the Sensor Control unit and AcraSensor are made by connecting each tube to the corresponding ports. Do not "tee" into these lines. Tube fittings (if supplied) correspond to the tube sizes listed below.

### Designation Connection Tube Size

P – Purge ..... 1/8 NPT ..... 1/4" tube

V – Vent..... 1/8 NPT ..... 1/4" tube

S – Signal..... 1/8 NPT ..... 1/4" tube

## CA—Compressed Air Requirements

Compressed air supply used for the Sensor Control and tank sensing unit must be clean, dry and oil-free. An instrument grade sub-micron rated compressed air filter should be installed in the main air supply line upstream of the feeds to individual Sensor Control(s).

If Sensor Control is mounted where freezing temperatures (32°F/0°C) may occur, compressed air supply must be adequately dry to prevent condensation from icing up the control. Use a compressed air dryer under these conditions.

**Caution:** Failure to use adequately filtered compressed air will result in poor performance and may void your warranty. A coalescing type compressed air filter with automatic sump drain is specifically recommended.

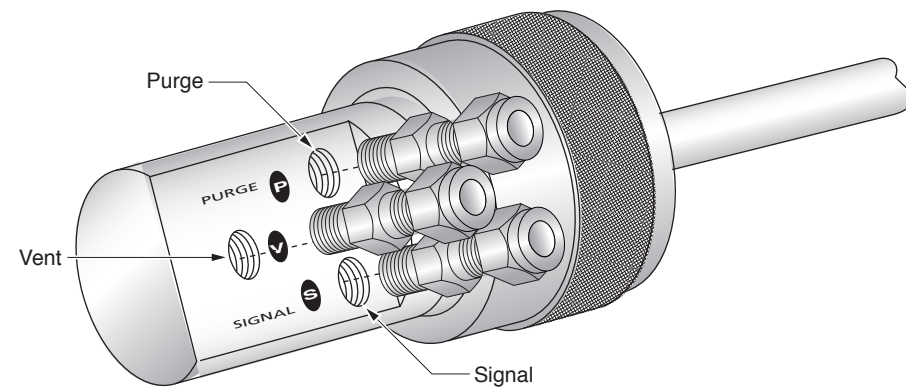

AcraSensor Connector

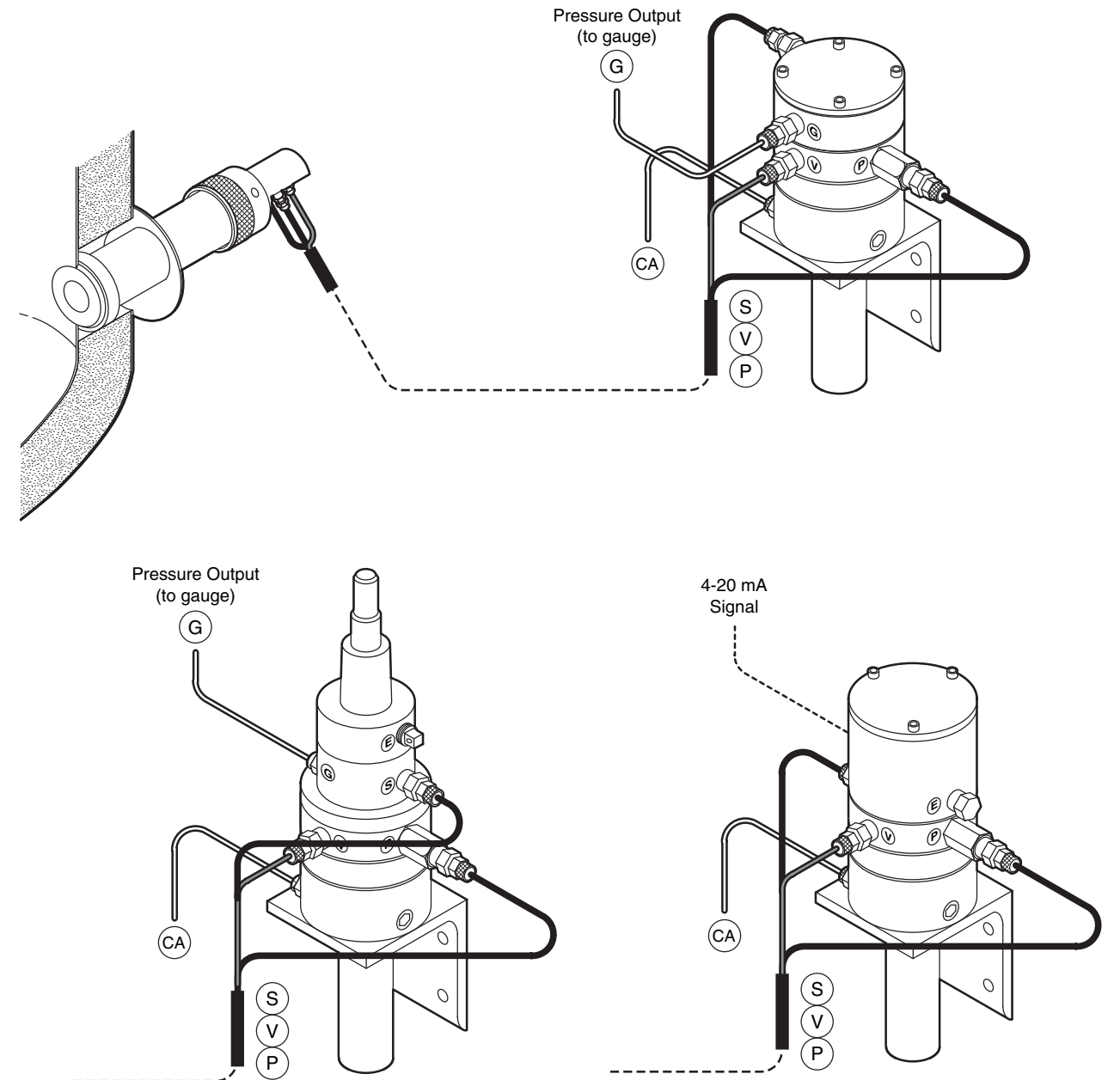

## INSTALLATION INSTRUCTIONS

### **KING-GAGE®** AcraSensor Pneumatic Tank Level Sensing Unit

			DATE	10/01/2010
C	10/10	Assy. revised w/ sleeve	DRAWN BY	D.Kennedy
B	11/02	Revised and redrawn	APPROVED	



DWG. NO.	<b>K-1060-1-8999</b>
SHEET	<b>2 OF 2</b>
REV.	<b>C</b>