

KING-GAGE®

4-20 mA Liquid Level Transmitter

ES2 Liquid Level Transmitter

Installation and Operation Instructions



© 2007 King Engineering Corporation.
All rights reserved.

The information contained in this manual was accurate at the time of release. Specifications are subject to change without notice.

Warranty - All King Engineering products are guaranteed to be free from defects in material and workmanship for one year from the date of purchase. Any product or part found to be defective under normal use within one year of purchase will be repaired or replaced at no charge if returned to the company at Ann Arbor, Michigan within ten days of discovery of the defect. No other warranties, whether expressed, implied, or statutory, including the warranties of fitness for a particular purpose or merchantability, are given by this agreement.

The exclusive remedy for nonconformity of these goods shall be repair and/or replacement of the nonconforming goods or parts.

Seller will not be liable for consequential damages resulting from breach of this agreement. The term "consequential damages" shall include but shall not be limited to damage to all machines, equipment and goods other than the goods sold hereby, interruption of production, loss of profits, delays of any kind, administrative expense and overhead.

Revisions:

- (A) August, 2004 – Original Release
- (B) December 2004 - Revision (pg 10)
- (C) Jan 2005 - housing details
- (D) April 2005 - Cable Recommended
- (E) November 2005 - Span Limits, mA output
- (F) January 2007 - M12 connector, voltage supply
- (G) April 2007 - added Model 550*-3R-**

Specifications

Pressure Ranges

0-5, 0-10, 0-15, 0-30, 0-50 psig
(Gage pressure measured relative to ambient atmospheric pressure)

Accuracy

Less than $\pm 0.20\%$ FS
Includes linearity, hysteresis, non- repeatability errors.

Pressure Media

Gas or Liquids compatible with 316 stainless steel (diaphragm); silicone rubber (O-ring). All other wetted parts 316L.

Electrical

Input (excitation): 14-40 Vdc
Output (mA): 4-20 milliamperes

Span Adjustment

Adjustable to 70-140% nominal range (-30% /+40%)

5 psig	0-3.5~7.0 (0-97 thru 194 in. water)
10 psig	0-7.0~14.0 (0-194 thru 387 in. water)
15 psig	0-10.5~21.0 (0-291 thru 581 in. water)
30 psig	0-21.0~42.0 (0-581 thru 1162 in. water)
50 psig	0-35.0~70.0 (0-969 thru 1937 in. water)

Non-Repeatability (Worst Case)

Less than 0.02% FS

Operating Temperature Range

0°F to 175°F/ -17°C to 79°C

Table of Contents

Specifications

Accuracy, Repeatability	Page 2
Span Adjustment Ranges	Page 2
Electrical input/output.....	Page 2
Temperature Range.....	Page 2

ES2 Transmitter Models

Mounting Dimensions.....	Page 5-6
--------------------------	----------

Signal Connections

Voltage/Load Capacity	Page 8
Signal Cable	Page 8
Signal (4-20 mA) connections	Page 8-10
Remote Box connections.....	Page 10

Zero/Span Calibration

Calibrating Range (span).....	Page 11
Span Adjustment - Coarse Setting.....	Page 12
When Output will be less than 20 mA.....	Page 13

Tank Gauging Applications

Calculating mA output.....	Page 13
Calculating tank pressure.....	Page 13

Service

Replacement parts	Page 14
-------------------------	---------

KING-GAGE ES2

Level Transmitter

Two-wire sensor/transmitter provides a direct 4-20 mA dc analog electronic output signal. The ES2 transmitter is designed specifically for hydrostatic pressure measurement for liquid level gauging.

Range Designation

The last two digits of the model number actually refer to the transmitter range. As an example, MODEL 5502-3-10 is a 0-10 psig range transmitter.

Model No. Designations

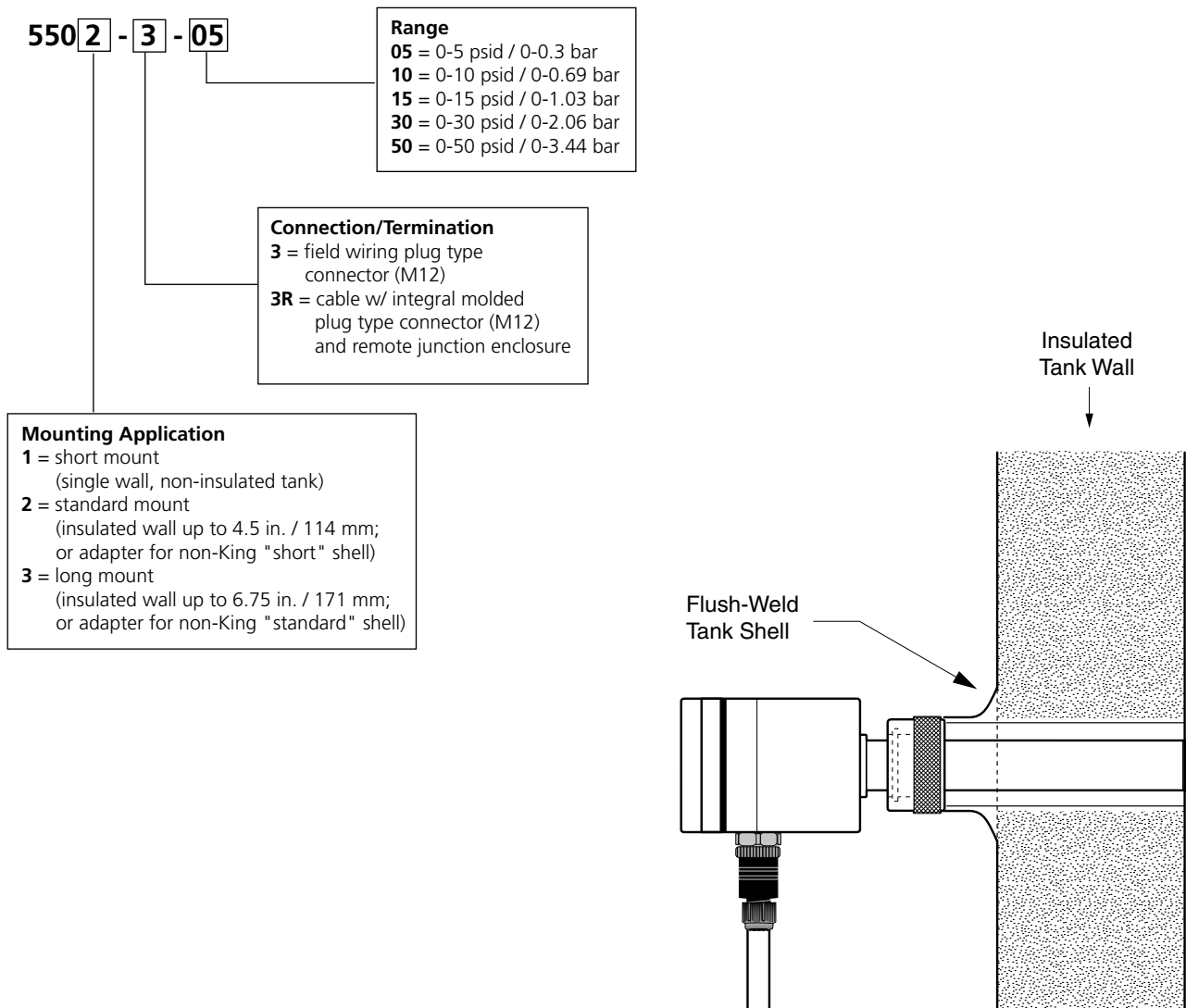

Mounting Dimensions

The ES2 Transmitter incorporates all associated user connections and adjustments within its integral stainless steel housing. The outlet connector boss is 1/2 NPT and furnished with a strain relief cord connector (accepts cable diameters between 0.187 in. to 0.25 in.). Mounting dimensions for the three (3) models vary in overall length only.

Allow adequate clearance for installation and removal of the transmitter. Clearance dimensions will vary depending upon type of cable/conduit connector used.

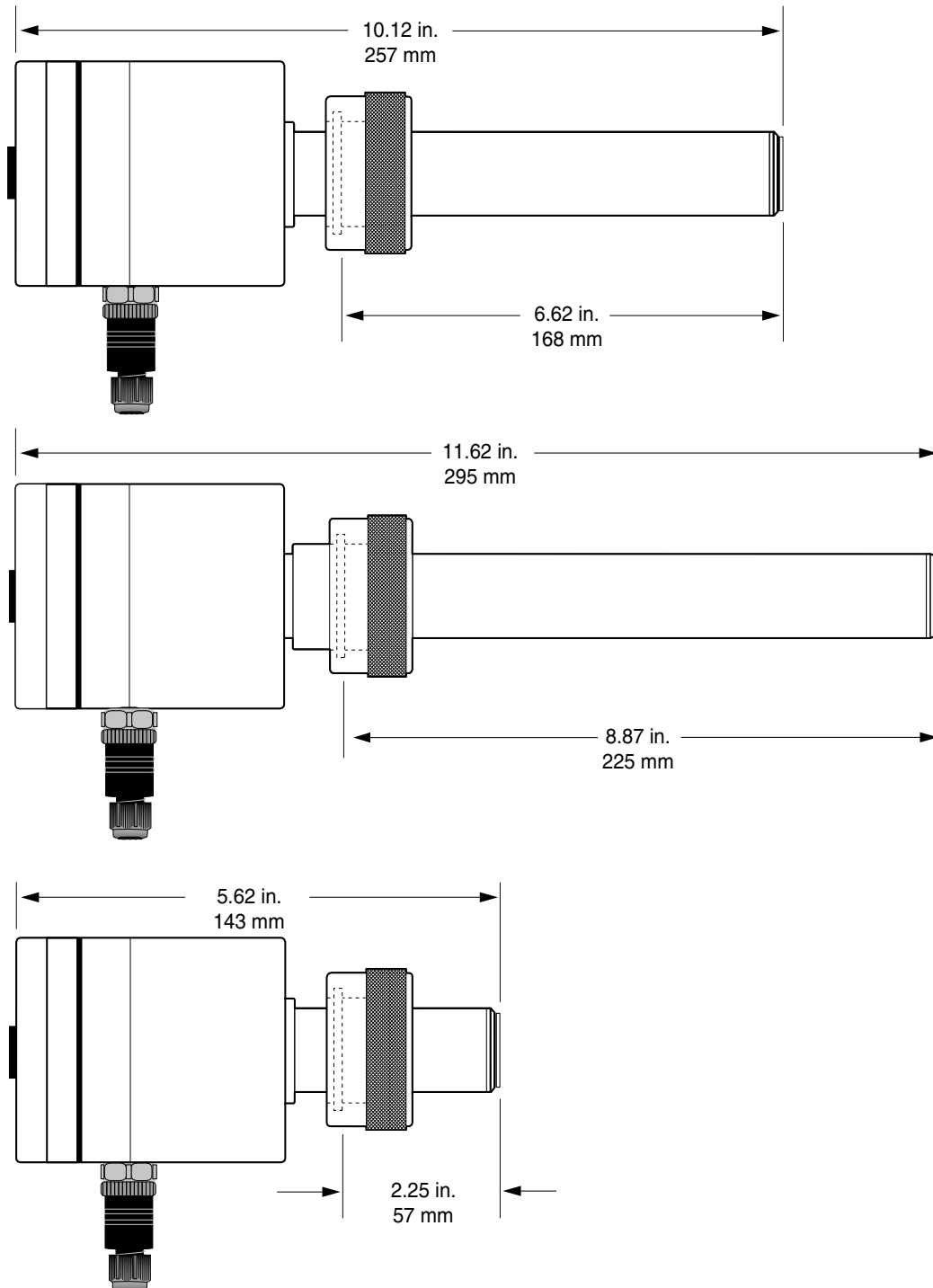

End View Mounting Dimensions

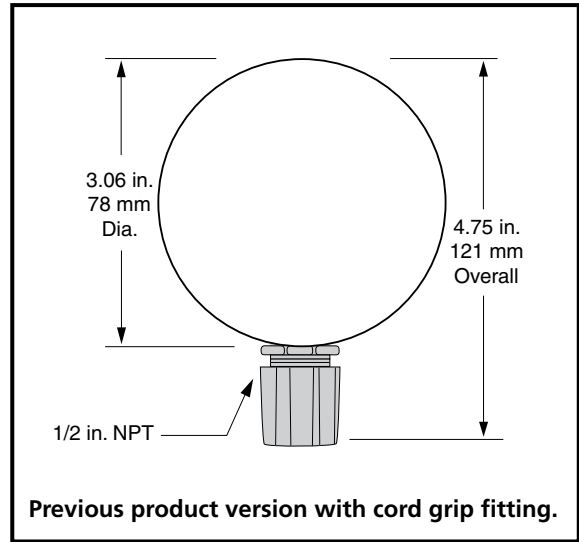
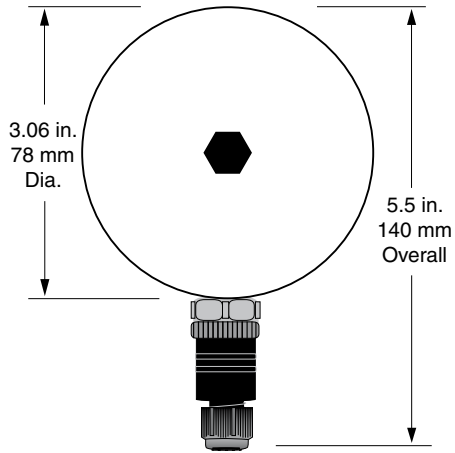

ES2 Transmitter shown with M12 plug-in field wiring connector (See page 9)

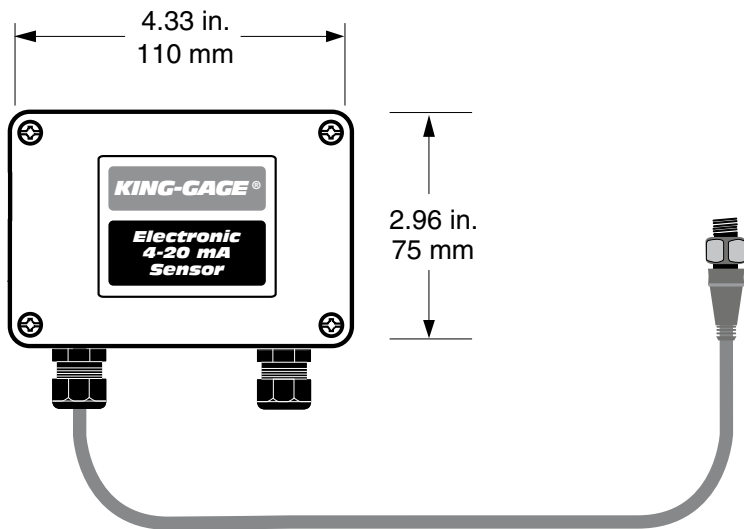

ES2 Optional Remote Junction Enclosure with Molded Cable Assembly

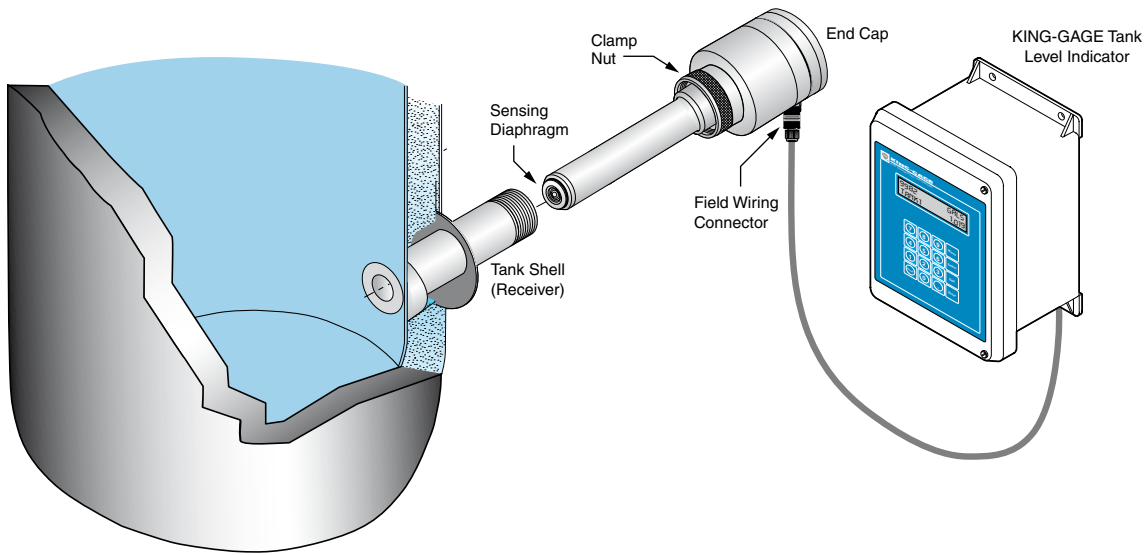

ES2 Liquid Level Transmitter Application
(typical system with tank level indicator)

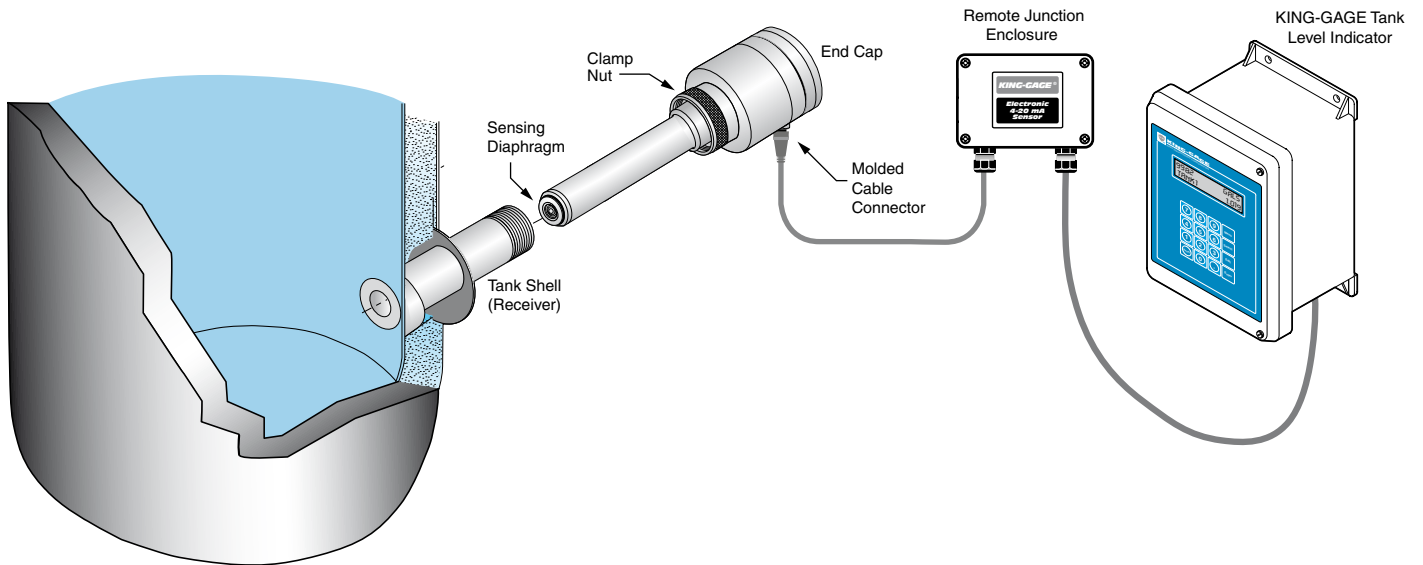

ES2 Liquid Level Transmitter with Remote Junction Enclosure
(typical system with tank level indicator)

Power Requirement

The ES2 transmitter requires a source of DC power for operation. Minimum excitation voltage must be no less than 14 Vdc. Any receiver installed on the signal loop (meters, data loggers, controllers, etc.) must be taken into account when determining the required power supply voltage to be used. The internal resistance of each device added together represents the total "load" residing on the signal loop circuit.

$$\text{Load Capacity} = \frac{(\text{Supply Voltage} - 14)}{(\text{OHMS})} \times .02$$

Load Capacity at Supplied Voltage

20 Vdc	24Vdc	28Vdc	32Vdc
300 ohms	500 ohms	700 ohms	900 ohms

KING-GAGE® tank processors and LevelBAR provide 24 Vdc excitation to power the signal loop circuit. (If the application requirement exceeds 500-ohms, an external power supply of appropriate voltage will be required.)

Transmitter Signal Cable

Use unshielded twisted pair cable (20-22 AWG) for the signal loop between transmitter and receiver.

NOTE: Avoid installing sensitive measuring equipment, or wire carrying low level signals, near sources of electrical and magnetic noise, such as breakers, transformers, motors, SCR drives, welders, fluorescent lamp controllers, or relays. Use twisted pair wiring to reduce magnetic noise pickup. Look for 10 to 12 twists per foot. Never run signal-carrying wires in the same conduit that carries power lines, relay contact leads, or other high-level voltages or currents.

The signal output is transmitted through 4-20 mA current loops that are low impedance electric circuits. Long cabling runs can increase the susceptibility for higher levels of noise to be transferred to the current loop circuit. Also, intermittent EMI or RFI with a changing frequency or intensity may induce interference on the transmitted output signal.

Recommended Signal Cable
 Unshielded twisted pair cable (UTP), 20-22 AWG
Example: Belden 9407

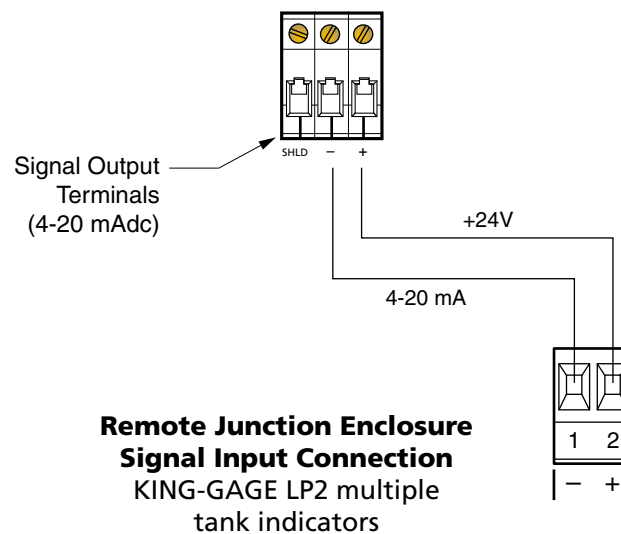
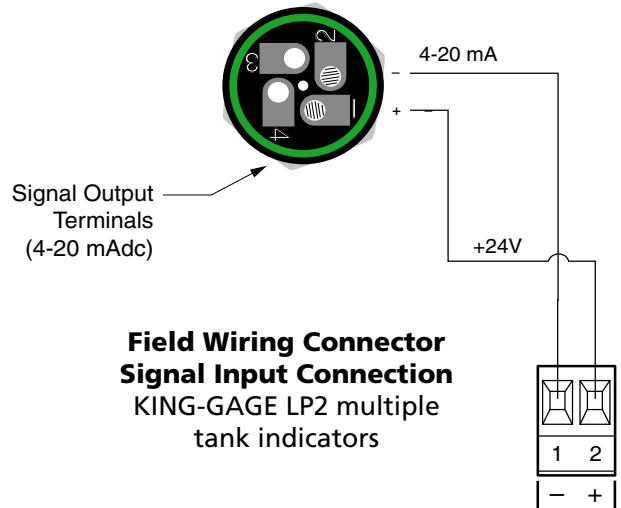

ES2 Signal Connection

ES2 transmitters are provided with an impermeable field wiring connector to ensure maximum protection against moisture infiltration of the transmitter housing. This connector is based on the M12 standard and can also be used with molded cable assemblies designed for this type of signal termination. The connector assembly as supplied allows for field wiring of the individual terminals (2) using standard two wire or twisted pair cabling.

Signal Cable

Please follow the installation instructions carefully to ensure that the connector assembly is adequately sealed to prevent corrosion of the field wiring terminals. This is especially critical when stripping back the cable sheath. We strongly recommend that cable be 20-22 AWG.

1. Strip back 1" (2.5 cm) of the outer cable sheath.
2. Strip back 1/4" (0.5 cm) of the insulation on each of the two conductors.

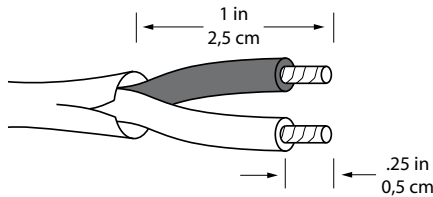

(NOTE: Cat 5e cable is composed of four pairs 24 AWG stranded conductors and not suggested for use when wiring the transmitter.)

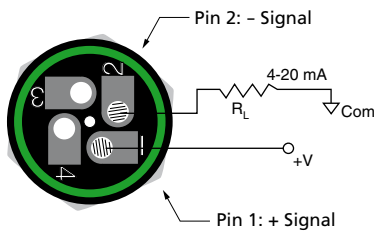

Connector Body - Detail



Field Wiring Connector

Field Wiring Connector

Refer to the diagram to access the field wiring terminals of the connector assembly. The connector body incorporates four (4) terminals – however, only two (2) terminals are used for the 4-20 mA signal loop. There may be numbers molded into the connector body specifying the PIN designations.

3. The connector body employs screw clamping terminals that require a small blade screwdriver. (Note that screws have been removed from the two unused terminals.)
4. Connect the positive + signal (typically red wire) to PIN 1.
5. Connect common or negative – signal (typically black wire) to PIN 2.

Assemble and Seal Connector

6. Make certain that the field wiring cable passes through the seal grommet and end cap.
7. Hand-tighten the compression sleeve until snug.
8. Hand-tighten the end cap until snug. Use a wrench to tighten an additional 1/2 turn.

Plug completed connector assembly into the external receptacle on ES2 housing (it is keyed for proper orientation). Hand-tighten the stainless steel connector nut onto the receptacle.



ES2 Housing Location of Receptacle

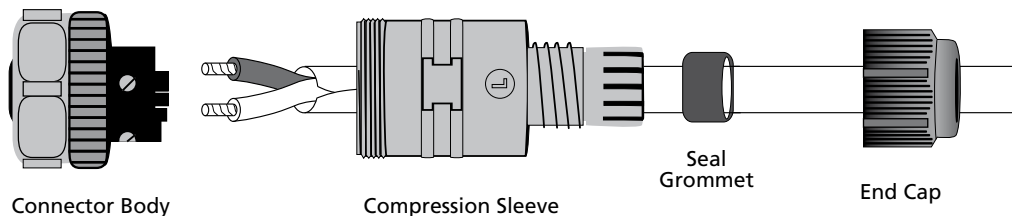

Field Wiring Connector Assembly

Internal Signal Connections

Screw clamp terminals are provided for positive (+ Signal) and negative (- Signal) or common sides of the signal loop circuit. As is typical of two-wire transmitters, all electrical power is supplied through the signal loop wiring. Refer to the Current Loop diagram for proper wiring of the circuit with polarity to the external power (+V) source.

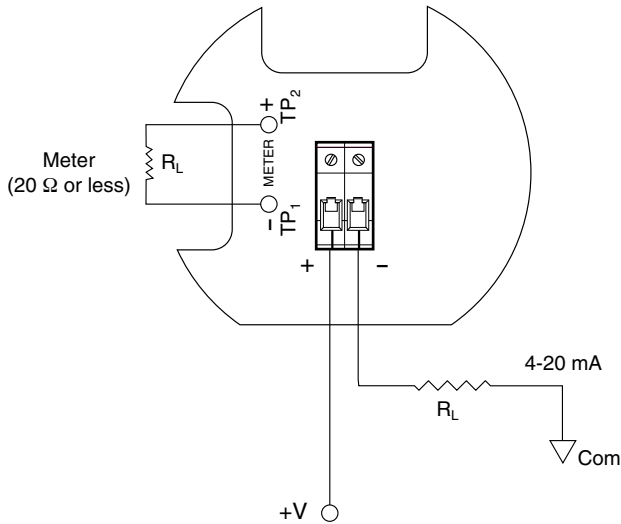

Test Point Terminals (TP1, TP2) – Test meter terminals are provided within the transmitter housing (see diagram) for measuring the output signal without disturbing the signal loop. Do not connect any device or meter whose internal resistance exceeds 20 ohms across these test points. Also refer to “In-Process Zero/Span Adjustment” in the following section.

NOTE: Older versions of the ES2 transmitter were not supplied with the external M12 plug connector described in the previous section. For units without the external connector, use the internal screw clamp terminals for making the signal loop wiring connections.

ES2 Optional Remote Junction Enclosure –
Signal Loop Connections and Remote Zero Adjust

When supplied with the remote junction enclosure, the molded cable assembly is connected to the receptacle provided on the ES2 transmitter housing. Signal loop connections are now conveniently extended to the junction enclosure (standard cable length is 16 ft/5 m). Open the enclosure to reveal the screw clamp type wiring terminals +/- Signal for connecting twisted pair cabling from the tank level indicator or remote receiver.

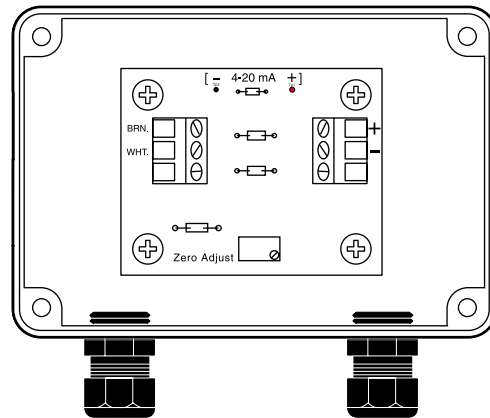

The junction enclosure package also includes a remote zero adjustment for the ES2 transmitter. (Note that span/zero settings have been factory preset and typically do not need adjustment during initial installation of the transmitter.) Test point terminals are provided within the junction enclosure for use with a multimeter.

ALWAYS USE THE TEST POINT TERMINALS within the remote enclosure when checking the signal output or making adjusting the zero setting of the transmitter. These are located at the top edge of the card and labeled as “- 4-20 mA +” (they are designed to easily accept the clip type leads used with a handheld meter).

ZERO ADJUST

Refer to “Adjusting Zero Setting” on the following page. (Note that there is no span adjustment available within the junction enclosure.)

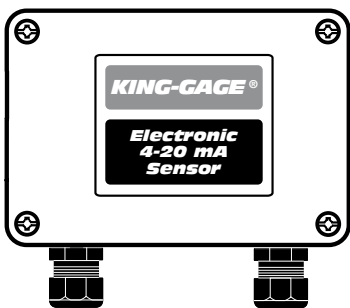

Molded Plug Type Cable & Remote Junction Enclosure (optional)

ES2 Calibration – Zero/Span Adjustment

This procedure is intended to recalibrate the existing zero and span output settings. It is generally recommended that the zero output be checked at least every 12 months. Generally speaking, slight adjustment of the zero potentiometer is all that is needed to maintain transmitter accuracy. However, since zero is an offset adjustment, shifting this setting upward or downward will have some corresponding effect on span.

Adjusting Zero Setting

Check zero by measuring the output using the meter terminal posts (TP1 & TP2) on the transmitter board.

- 1-1. Adjust zero potentiometer as necessary to increase output (clockwise) or decrease output (counterclockwise) until the signal displays as 4.00 or 4.01 mA on the test meter.

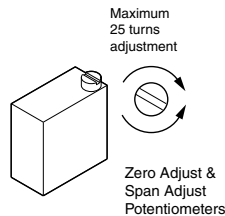

Adjusting Span Setting

This requires applying pressure to the face of the ES2 sensing diaphragm equivalent to the maximum depth (hydrostatic) pressure. Measure the output using the meter terminal posts on the transmitter board.

- 1-2. Adjust span potentiometer as necessary to increase output (clockwise) or decrease output (counterclockwise) until the signal displays as 20.00 or 20.01 mA on the test meter.
- 1-3. Next step is to re-check the zero output and slightly adjust if necessary.

In-Process Zero/Span Adjustment

It is possible to make adjustments to the zero setting while the ES2 transmitter is installed at the tank. The meter terminal posts permit in-process monitoring without disturbing the loop wiring. Confirm that the tank is empty (or liquid level is below sensor). Measure the transmitter output using a milliammeter and adjust zero potentiometer as required.

Using Multimeter: Set multimeter for DC current, using mA or .001 amp scale. The internal resistance of the meter must be 20 ohms or less since higher resistance values will create incorrect readings. Connect the meter leads to the **TP1** and **TP2** posts on the internal circuit board.

Adjusting span settings of an installed transmitter is not a very precise method for calibration (since the hydrostatic pressure may not be accurately determined). In-process span adjustment is not recommended for this reason.

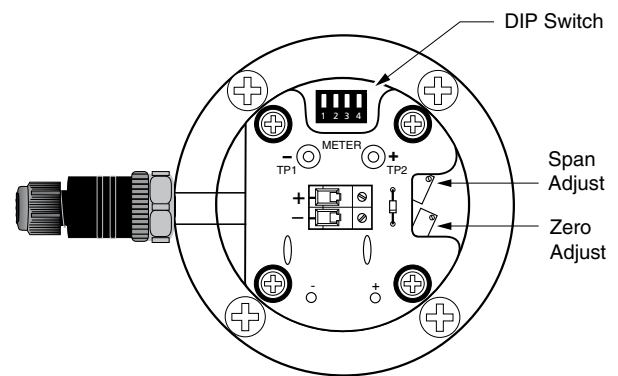

ES2 Range Adjustment DIP Switch Settings

The ES2 transmitter span can be adjusted from 70% to 140% of the nominal range indicated by the model number. (Refer to Model No. Designation on page 3.) This is how the transmitter's pressure range can be changed for a specific application. When the ES2 transmitter is used with a KING-GAGE® digital tank level indicator, the "Application Datapack" (SRAM or iButton memory module) is generally programmed with the nominal range setting. The indicator programming will correlate the output signal to tank capacity regardless of whether the maximum tank level generates less than 20.00 mA output from the transmitter.

WHEN NOT TO CHANGE SPAN - If a KING-GAGE indicator is part of the system, you should not have to change the range (span) of the transmitter.

Coarse Range Setting

An initial coarse range setting is provided by the DIP switches. Use the previously outlined Zero/Span Calibration to achieve the final trim setting for precise 4.00-20.00 mA output over the intended pressure range.

The DIP switches on the transmitter circuit board affect the span (range) of the transmitter. These provide coarse adjustment in addition to the fine span adjustment of the potentiometer. Please refer to the individual DIP switch positions listed for adjusting the existing setting of the transmitter.

The four (4) switches provide 16 increments of coarse adjustment. Prior to changing any switch setting, check the current output of the transmitter at the desired upper pressure value. Also note the existing switch setting.

- 2-1. Apply the desired maximum pressure to the sensing diaphragm of the ES2 transmitter (requires a pressure test shell available from King Engineering).
- 2-2. Record the existing setting positions of the DIP switches.
- 2-3. Adjust the potentiometer to maximum output by turning clockwise until it "clicks".
- 2-4. To increase the milliamp output, use a higher switch setting arrangement; to reduce the milliamp output, use a lower switch setting arrangement. (The goal is to achieve a output signal value just slightly above 20 milliamps and then use the potentiometer to trim the setting.)
- 2-5. Follow the Zero/Span Calibration procedure to check both the zero and span output.

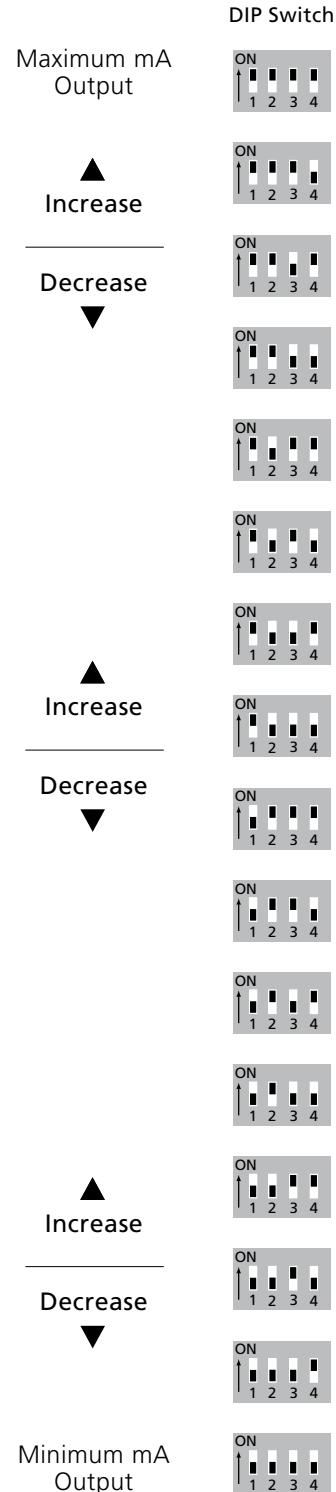

Coarse Range Setting – Alternate Version

Previous versions of the ES2 transmitter employ similar DIP switches, but only offer 5 increments of coarse adjustment. With these versions, the span potentiometer offers greater range of adjustment.

Coarse Setting Procedure: The number of switches in the ON position will increase the milliamp value as each switch controls an identical fixed resistor. To increase milliamp output, place additional switches into the ON position. To decrease milliamp output, move switches to the off position.

Calculating Milliamp Output

When Output will be Less Than 20 mA...

■ Maximum Pressure Below 3.00 PSI

When the nominal 5 PSI transmitter is used on an application whose maximum pressure is less than 3.00 PSI, the full calculated range output will be less than 20 mA. To determine the actual milliamp output of the transmitter when the maximum applied pressure is below the lower span limit, use the following formula:

$$\frac{(16 \times \text{Calculated PSI})}{3.0} + 4 = \text{mA Output}$$

The King-Gage® ES2 transmitter is factory-calibrated to nominal range only. Unless span is adjusted for a specific calculated pressure range, the milliamp output of the sensor at full tank level will generally be less than 20.00 mA.

Actual output can be calculated based on total tank depth and specific gravity of the liquid product:

$$\frac{(B - A) \times C}{27.6807} = \text{Tank Pressure}$$

where ...

- A** = Reserve (inches of depth from low point of tank to sensor)
- B** = Full Tank (inches of depth from low point of tank to full)
- C** = Specific Gravity of Tank Contents

Now, using the calculated tank pressure from above, the actual milliamp value at full can be determined:

$$\frac{(16 \times \text{Tank Pressure})}{\text{NOMINAL psig RANGE}} + 4 = \text{mA Output}$$

(NOTE: If pressure range is adjusted between 70% or 140% of nominal, refer to the calculation referenced on page 8 for determining milliamp output.)

Example - mA Output Calculation for Tank Gauging Application

The following example shows how the milliamp output of the sensor at full tank can be calculated. The “Reserve” represents the distance from the lowest point on the bottom of the tank to the installed sensor. “Full” is the level of contents at which the tank is filled to capacity. The liquid contents of the tank is milk @ 1.032 sp.gr. The sensor installed is a nominal 15 psig range model.

C = 1.032 (specific gravity)

B = 400 in. (full level)

A = 28 in. (reserve)

$$\frac{(400 - 28) \times 1.032}{27.6807} = 13.87 \text{ psig}$$

$$\frac{(16 \times 13.87)}{15 \text{ psig}} + 4 = 18.79 \text{ mA}$$

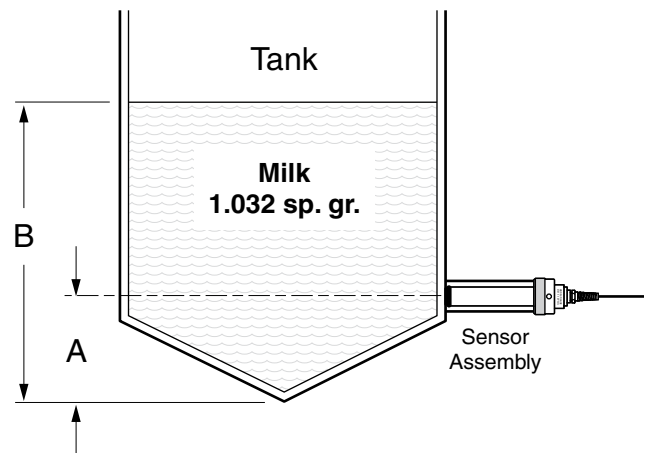

Service Parts & Replacement

O-Ring Seals

The outer O-ring at the head of the sensing element forms the critical seal at the tank mounting and should be replaced if there are signs of physical damage (such as a cut). If replacement seal is needed, refer to the part number called out in the illustration.

The end cap of the housing seals against an O-ring on the end of the housing. If this O-ring is missing or damaged, moisture may infiltrate the housing. (Order Replacement O-ring 6554-150)

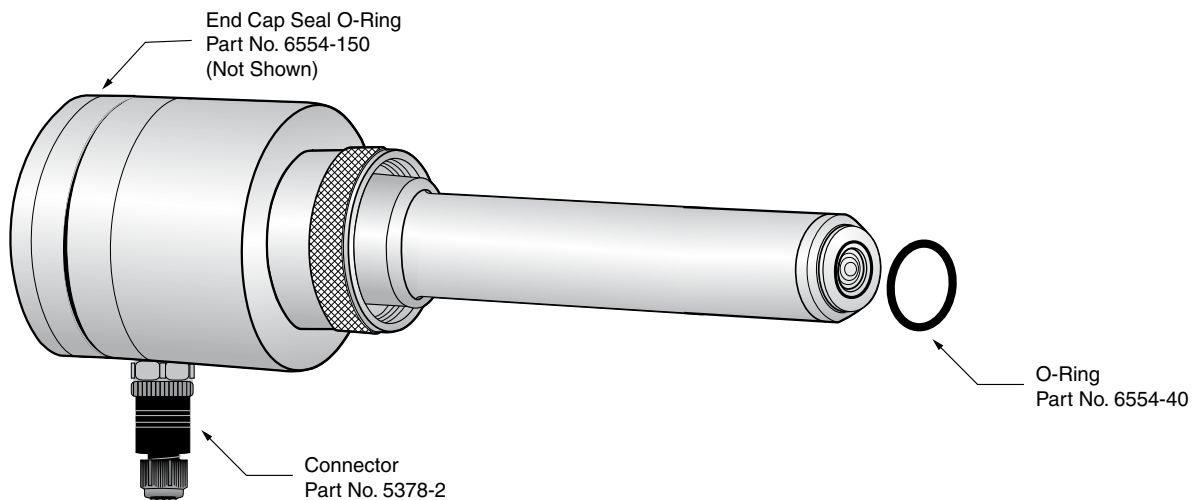

This Page Intentionally Left Blank



3201 South State St, Ann Arbor, Michigan 48108-1625 U.S.A.

PO Box 1228, Ann Arbor, Michigan 48106-1228 U.S.A.

Phone: (734) 662-5691 ▪ FAX: (734) 662-6652

www.king-gage.com