

## Application Notes

### Read before installing transmitter

**Mounting:** This transmitter is designed for installation within a tank shell or fitting adapter manufactured by King Engineering Corp. (i.e., KING-GAGE). This is typically a fitting for flush mounting of the transmitter or an external pipe flange adapter.

**Power Requirement\***  
14-40 Vdc (excitation voltage)

**Output Signal**  
4-20 mAdc

**Operating Temperature Range**  
0°F to 175°F / -17°C to 79°C

\* KING-GAGE® LevelBAR indicators and LP2 tank indicators incorporate a 24 Vdc output to power the transmitter.

### Mounting Transmitter at Tank

1. The transmitter is installed within a flush-weld mounting shell through the tank wall, or within an adapter to mate to an existing tank fitting.
2. Check that O-ring is properly seated in groove around the diaphragm face of transmitter.
3. Carefully insert the transmitter into the fitting or adapter. Avoid bumping the diaphragm face against hard surfaces.
4. Hand tighten the clamp nut until snug.

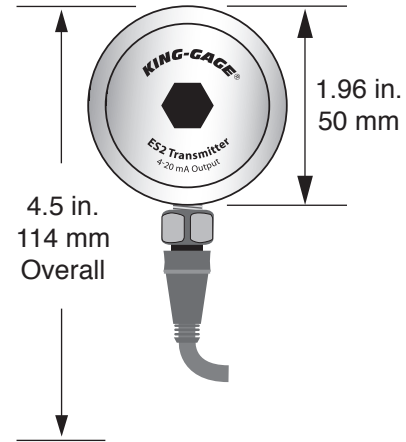
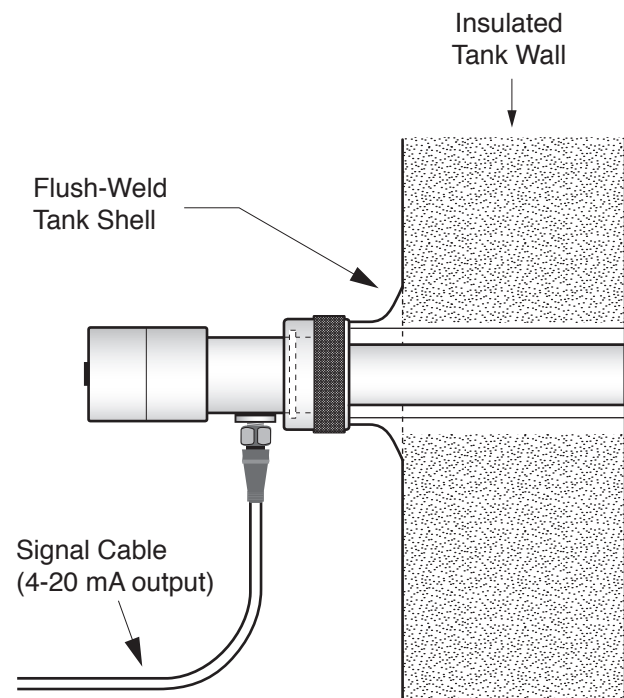

**CAUTION! DO NOT** – Bump or strike face of transmitter or allow water to enter transmitter. Do not passivate tank with transmitter installed

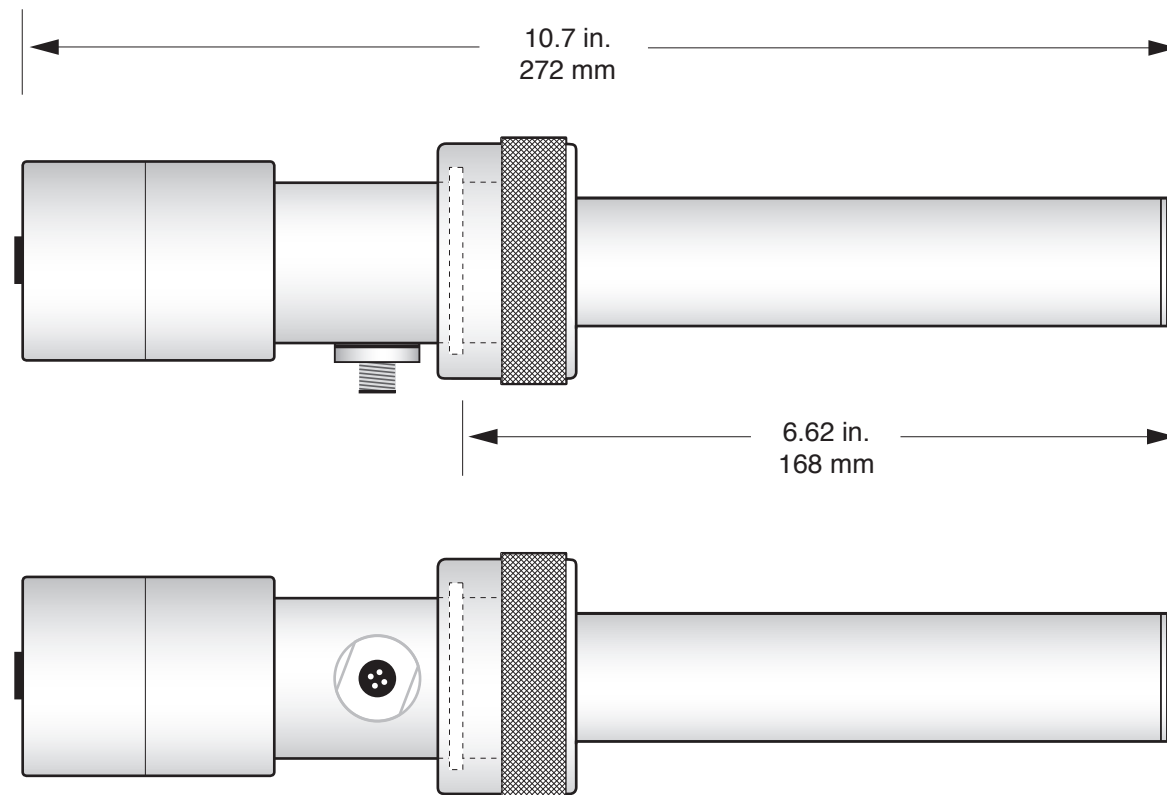

REV.	DESCRIPTION	DATE	APP'D
D	Connector revisions	12/14/06	✓ [Signature]
E	Version ES2.5	11/28/07	
F	Molded cable assembly shown	10/13/08	
G	Revised housing, dimensions	10/23/09	

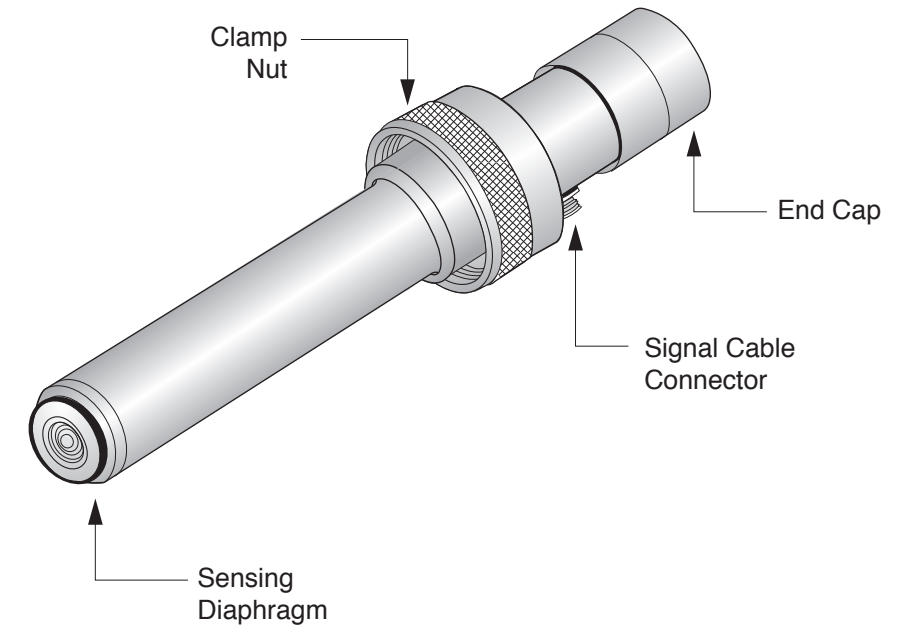

### Transmitter Model No.

5502-3-05	Range: 0-5 psig
5502-3-10	Range: 0-10 psig
5502-3-15	Range: 0-15 psig
5502-3-30	Range: 0-30 psig
5502-3-50	Range: 0-50 psig

## INSTALLATION INSTRUCTIONS

**KING-GAGE®**  
**ES2 Standard Mount Transmitter**  
**Model 5502-3-xx**

DATE	10/23/09
DRAWN	D. Kennedy
APP'D	jg



<b>K-1090-3-5502</b>		REV. <b>G</b>
SHEET <b>1</b>	OF <b>2</b>	

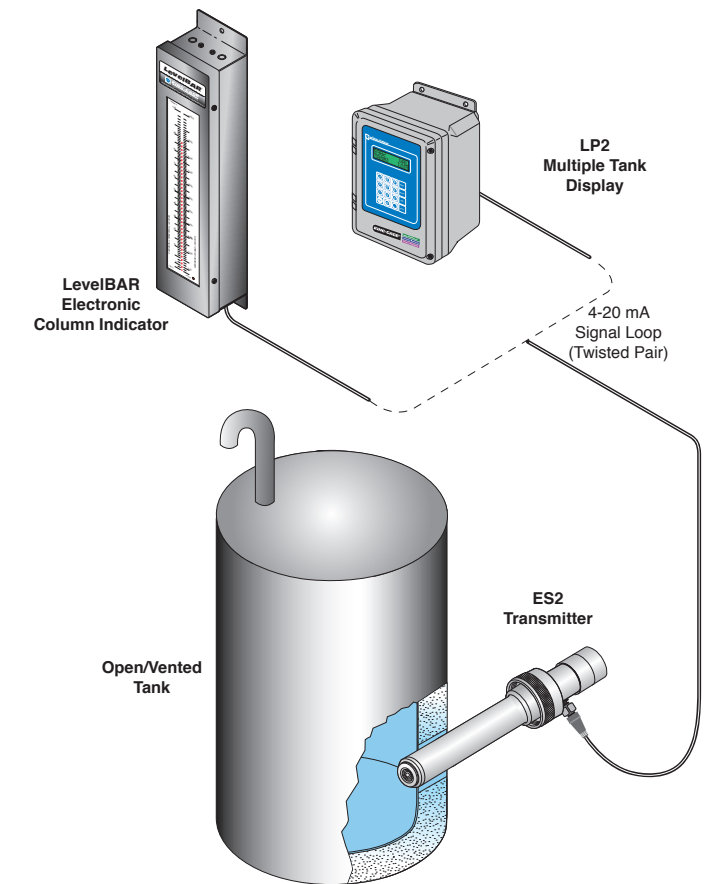
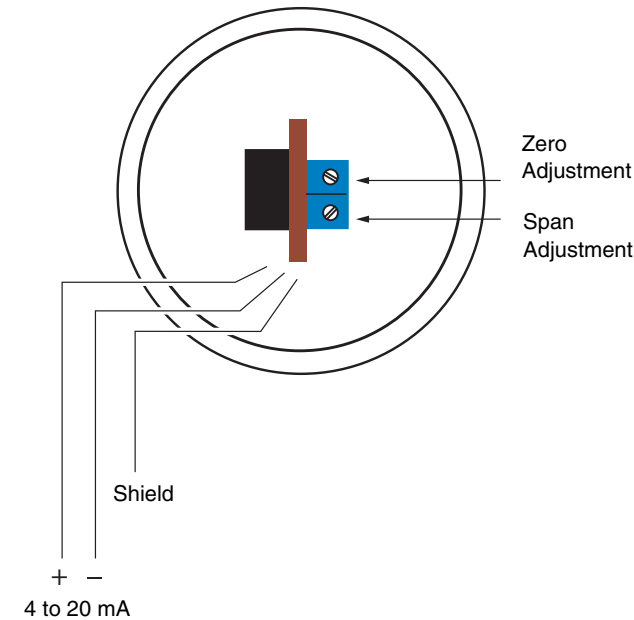
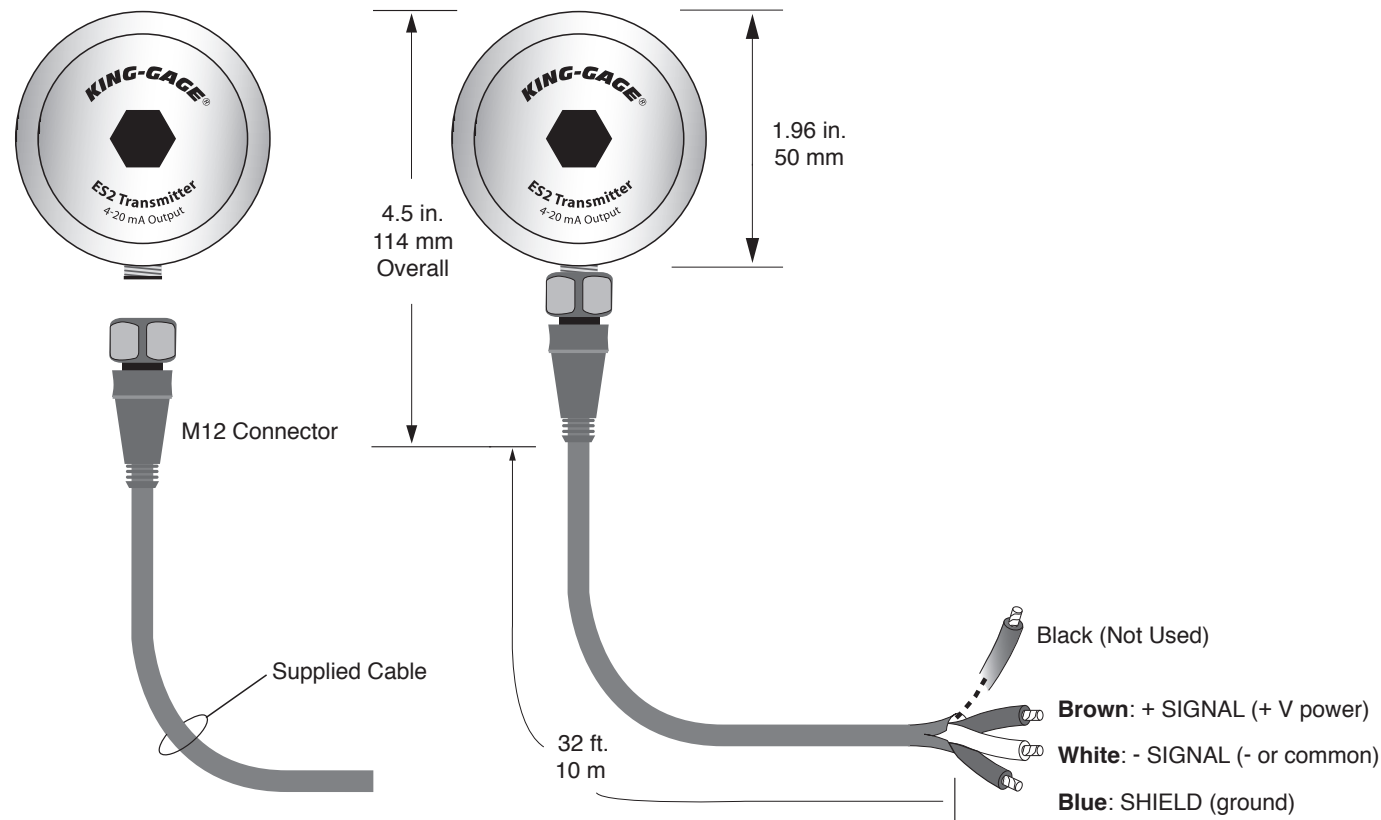

### ES2 Signal Connection

ES2 transmitters are provided with an impermeable field wiring connector to ensure maximum protection against moisture infiltration of the transmitter housing. This external connector receptacle has a metric M12 screw collar and is intended for plug type molded cable assemblies designed for 4-pole signal termination. (Note that only 3 conductors are utilized for the transmitter output wiring, as noted below.)

### Supplied Signal Cable

The supplied cable includes a molded plug connector that mates to the M12 receptacle of the ES2 transmitter housing. Note that only 3 conductors of the cable are used to convey the 4-20 mA output signal that includes ground or shield (BROWN +, WHITE -, BLUE Gnd/Shield).

BROWN	+ signal
WHITE	- signal
BLUE	Gnd (shield)
BLACK	N/A (not used)

Conductors should be securely fastened to the termination point (terminal block, etc). If cable is spliced, it is recommended to solder the wires to ensure positive connection or use suitable crimp butt splice wire connectors.

### Power Requirement

The ES2 transmitter requires a source of DC power for operation. Minimum excitation voltage must be no less than 14 VDC. Any receiver installed on the signal loop (meters, data loggers, controllers, etc.) must be taken into account when determining the required power supply voltage to be used. The internal resistance of each device added together represents the total "load" residing on the signal loop circuit.

$$\text{Load Capacity} = \frac{(\text{Supply Voltage} - 14)}{(\text{OHMS}) \cdot .02}$$

### Load Capacity at Supplied Voltage

20 Vdc	24Vdc	28Vdc	32Vdc
300 ohms	500 ohms	700 ohms	900 ohms

## INSTALLATION INSTRUCTIONS

**KING-GAGE®**  
**ES2 Standard Mount Transmitter**  
**Model 5502-3-xx**

DATE	10/23/09
DRAWN	D. Kennedy
APP'D	jg



K-1090-3-5502	
SHEET	REV.
2 OF 2	G