

Application Notes

Read before installing transmitter

Mounting: This transmitter is designed for installation within a tank shell or fitting adapter manufactured by King Engineering Corp. (i.e., KING-GAGE). This is typically a fitting for flush mounting of the transmitter or an external pipe flange adapter.

Supplied Cable and Enclosure: The supplied cable includes a molded plug connector that mates to the M12 receptacle of the ES2 transmitter housing. Note that only 2 conductors of the cable are used to terminate within the junction enclosure (BROWN +, WHITE -). The remote junction enclosure provides screw clamp type terminals for the external signal loop wiring, isolated test meter terminals and zero adjustment potentiometer. Entry points at the junction enclosure are provided with watertight cord grip fittings for the sensor cable and external signal transmission wiring.

IMPORTANT! Avoid mounting Junction Enclosure in locations subjected to frequent washdown. Mount enclosure as high above the floor as practical.

Power Requirement*
14-40 Vdc (excitation voltage)

Output Signal
4-20 mAdc

Operating Temperature Range
0°F to 175°F / -17°C to 79°C

* KING-GAGE® LevelBAR and LP2 tank indicators incorporate a 24 Vdc output to power the transmitter.

CAUTION! DO NOT – Bump or strike face of transmitter. Do not passivate tank with transmitter installed. ES2 transmitter has been factory calibrated with the remote zero/terminal board supplied. Changing this pairing may necessitate readjustment of the transmitter.

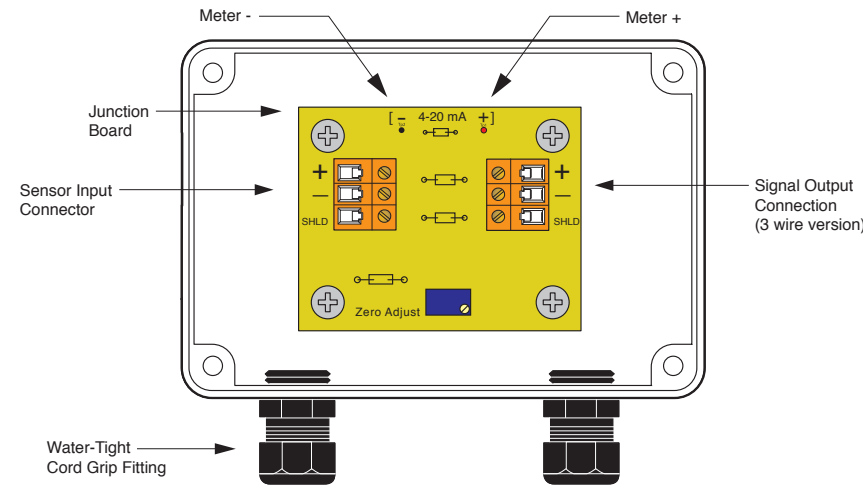
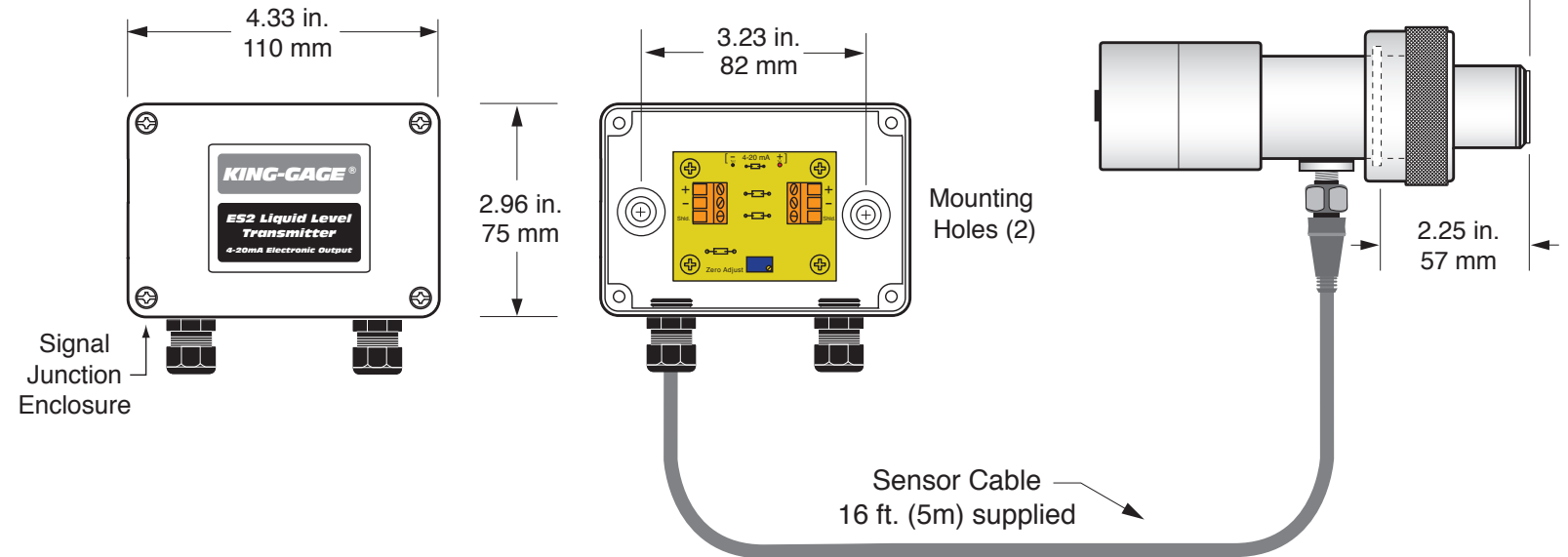

Interior View - Junction Enclosure

Power Requirement

The ES2 transmitter requires a source of DC power for operation. Minimum excitation voltage must be no less than 14 VDC. Any receiver installed on the signal loop (meters, data loggers, controllers, etc.) must be taken into account when determining the required power supply voltage to be used. The internal resistance of each device added together represents the total "load" residing on the signal loop circuit.

$$\text{Load Capacity} = \frac{(\text{Supply Voltage} - 14)}{.02} \text{ (OHMS)}$$

Load Capacity at Supplied Voltage

20 Vdc	24Vdc	28Vdc	32Vdc
300 ohms	500 ohms	700 ohms	900 ohms

Transmitter Model No.	
5501-3R-05	Range: 0-5 psig
5501-3R-10	Range: 0-10 psig
5501-3R-15	Range: 0-15 psig
5501-3R-30	Range: 0-30 psig
5501-3R-50	Range: 0-50 psig

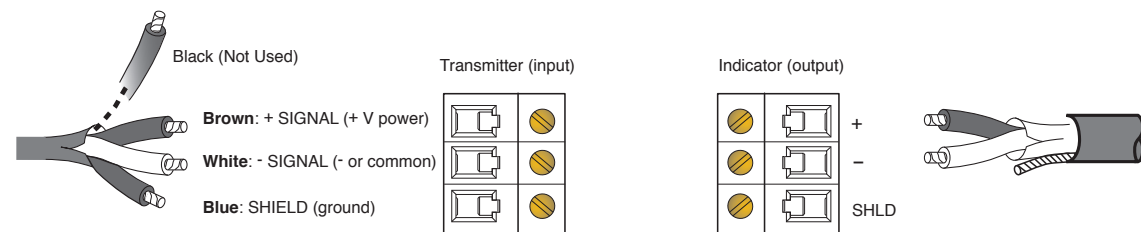

Junction Enclosure Terminals

REV.	DESCRIPTION	DATE	APP'D
E	Version ES2.5	11/28/07	
F	Junction Board Revision	3/18/08	X
G	Revised housing, dimensions	10/29/09	

INSTALLATION INSTRUCTIONS

ES2 Transmitter - Short Mount w/ molded cable & junction enclosure Model 5501-3R-xx

DATE	10/29/09	KING ENGINEERING CORPORATION <small>Since 1937</small>	DWG NO.
DRAWN	Kennedy		K-1090-1-5501
APP'D	jg	Box 1228, Ann Arbor, Michigan 48106-1228 U.S.A. Phone: (734) 662-5691 • FAX: (734) 662-6652 www.king-gage.com	SHEET
			1 OF 2

Mounting Transmitter at Tank

1. The transmitter is installed within a flush-weld mounting shell through the tank wall, or within an adapter to mate to an existing tank fitting.
2. Check that O-ring is properly seated in groove around the diaphragm face of transmitter.
3. Carefully insert the transmitter into the fitting or adapter. Avoid bumping the diaphragm face against hard surfaces.
4. Hand tighten the clamp nut until snug.

Mounting Junction Enclosure

- Refer to overall clearance dimensions as shown on SHEET 1.
5. Remove cover from enclosure to install fasteners (screws or bolts are not supplied).
 6. Anchor securely to wall or other structural surface within 15 feet of transmitter location.

Output Signal Connections

- Remove cover to access internal connections (see Sheet 1). Power is supplied to the transmitter through the signal loop from the receiver or separate power supply.
7. Use unshielded twisted pair cable (20-22 AWG) for the signal loop between the transmitter and receiver.
 8. Insert stripped end of each wire into the connector and tighten screw to securely clamp it in place. Maintain proper + (positive or "signal") and - (negative or common) polarity as depicted in these diagrams.
 9. Use supplied cord connector fitting or install appropriate 3/8 in. NPT conduit hub at junction enclosure.
 10. Keep housing closed following installation.

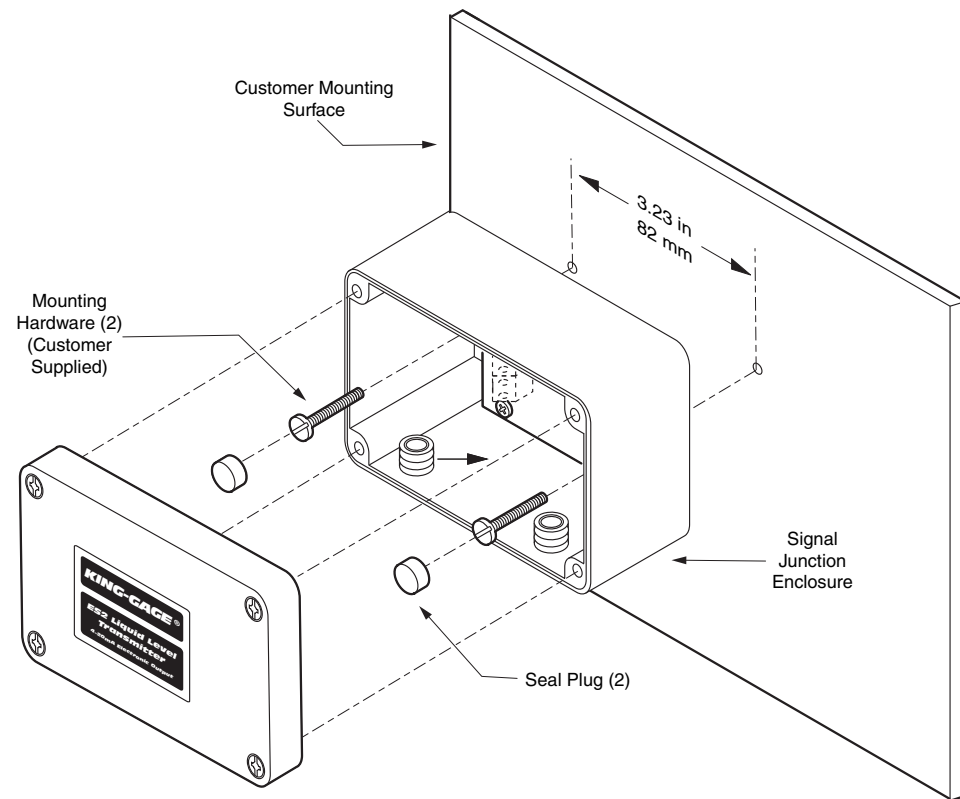

Detail- Mounting Junction Enclosure

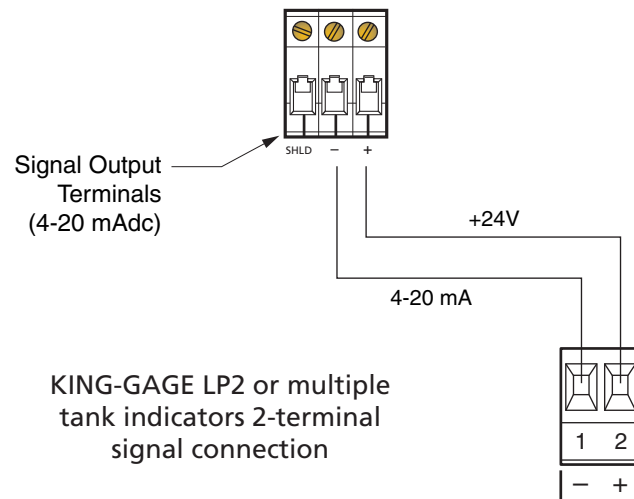
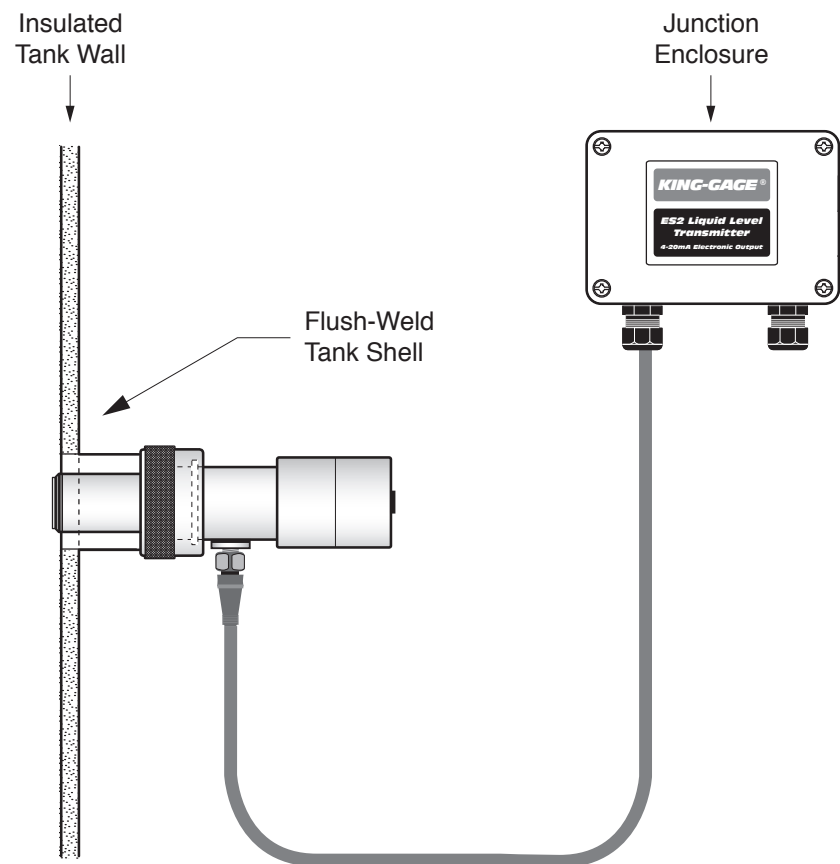

KING-GAGE LP2 or multiple tank indicators 2-terminal signal connection

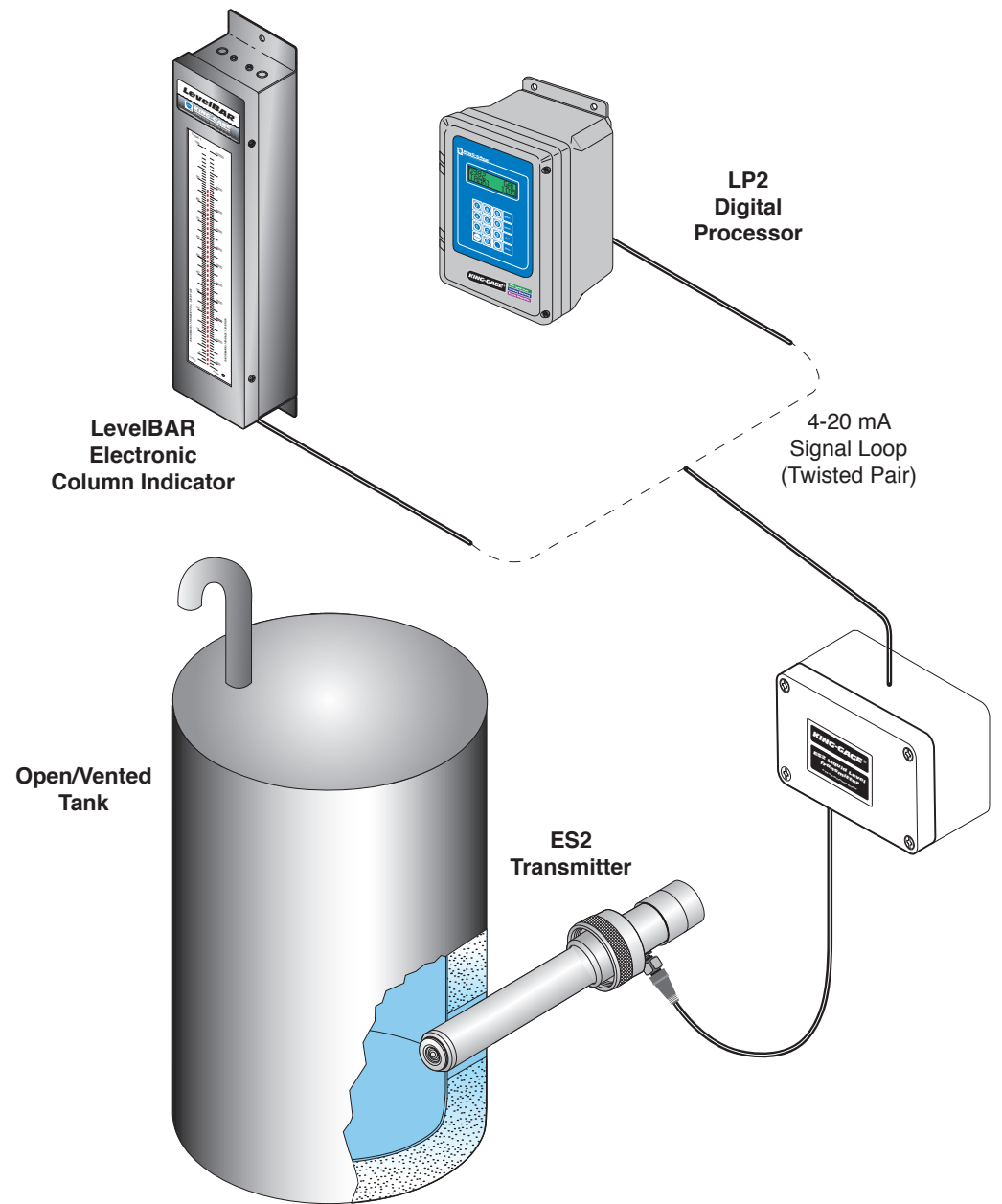

INSTALLATION INSTRUCTIONS

KING-GAGE®
ES2 Transmitter - Short Mount
w/ molded cable & junction enclosure
Model 5501-3R-xx

DATE	10/29/09
DRAWN	Kennedy
APP'D	jg



DWG NO.	K-1090-1-5501
SHEET	2 OF 2
REV.	G