

KING-GAGE®

AcraSensor Liquid Level Pressure Sensors

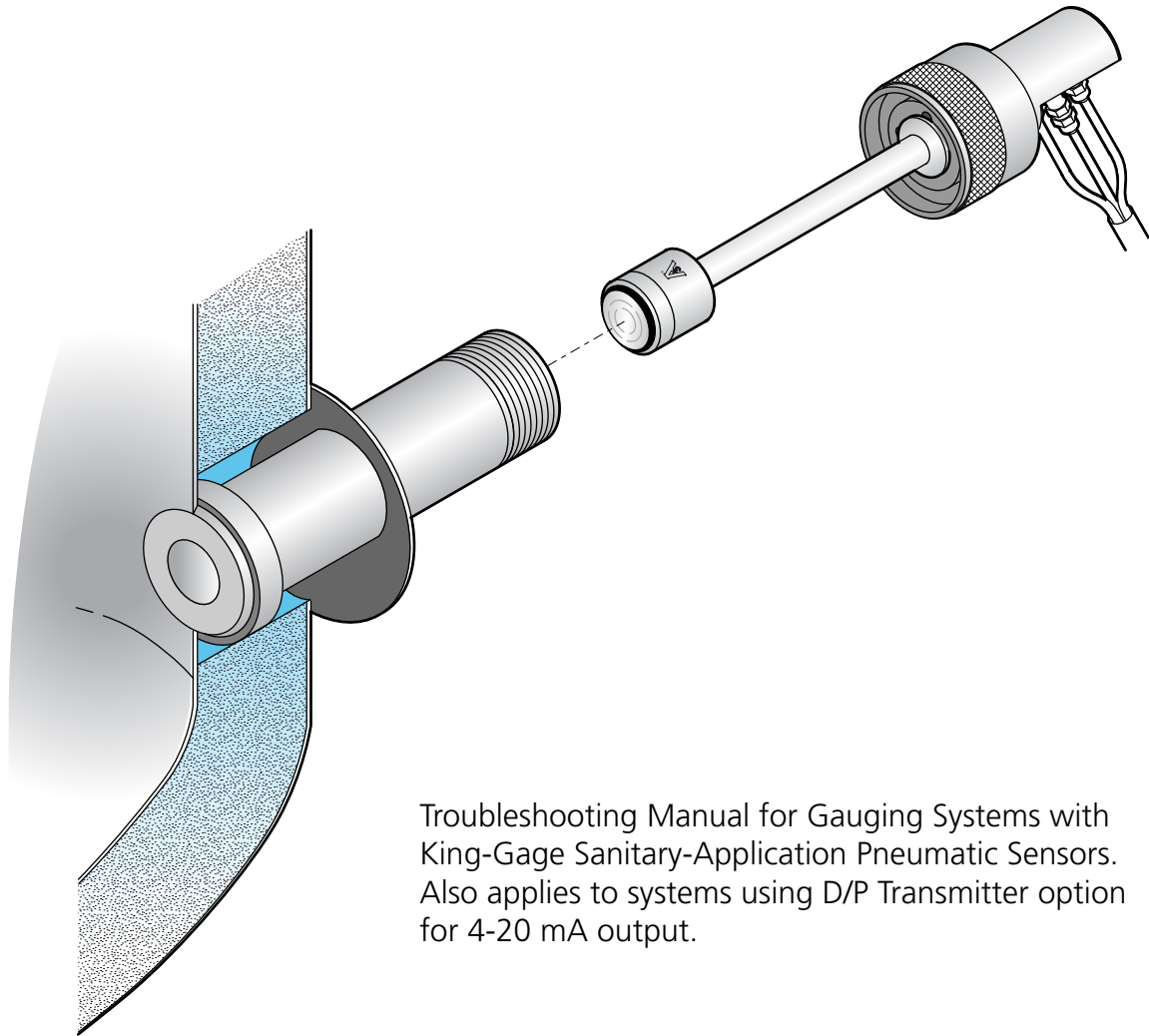

Troubleshooting Manual for Gauging Systems with King-Gage Sanitary-Application Pneumatic Sensors. Also applies to systems using D/P Transmitter option for 4-20 mA output.

© 2006 King Engineering Corporation.
All rights reserved.

The information contained in this manual was accurate at the time of release. Specifications are subject to change without notice.

Warranty - All King Engineering products are guaranteed to be free from defects in material and workmanship for one year from the date of purchase. Any product or part found to be defective under normal use within one year of purchase will be repaired or replaced at no charge if returned to the company at Ann Arbor, Michigan within ten days of discovery of the defect. No other warranties, whether expressed, implied or statutory, including the warranties of fitness for a particular purpose or merchantability, are given by this agreement. The exclusive remedy for nonconformity of these goods shall be repair and/or replacement of the nonconforming goods or parts.

Seller will not be liable for consequential damages resulting from breach of this agreement. The term "consequential damages" shall include but shall not be limited to damage to all machines, equipment and goods other than the goods sold hereby, interruption of production, loss of profits, delays of any kind, administrative expense and overhead.

Revisions:

- (A) July, 1979 – Original Release
- (B) January, 1988 – Revised/Expanded w/ New Format
- (C) July, 1995 – Revised/Redrawn
- (D) November, 2006 – Deleted ref. to 760 series

Table of Contents:

Specifications/Dimensions	Page 4
AcraSensor - Titanium Metal Diaphragm Sensor	
Exploded View of Diaphragm Unit Assembly	Page 5
AcraSensor - Silicone Rubber or Buna-N Diaphragm Sensor	
Exploded View of Diaphragm Unit Assembly	Page 6
Connector Assembly with Barrel Insert Cable Connector	Page 7
Complete Sensor Package w/ Sensor Control	
Pneumatic Output.....	Page 8
4-20 mA Output (D/P Sensor Control)	Page 9
Preliminary - Operational Requirements	
Tube Connections, Compressed Air Supply.....	Page 10
Troubleshooting Checklist	Page 10
Troubleshooting and Problem Diagnosis	
Symptom #1 - High Reading (Empty Tank).....	Pages 11 - 12
Symptom #2 - Negative Reading (Empty Tank)	Page 12
Symptom #3 - Negative Reading (Full Tank).....	Page 12
Symptom #4 - High Reading (Full Tank)	Page 13
Symptom #5 - Low or No Reading (Full Tank)	Pages 14 - 15
Symptom #6 - Reading Stops Rising	Page 15
Symptom #7 - Overpressure Condition.....	Page 15
Symptom #8 - Fluctuating/Bouncing Reading	Page 16
Reference Documentation	Page 16

Specifications -

Diaphragm Material

- .001"
commercially-pure titanium or
- .015" silicone rubber, FDA-approved

Sensitivity

Less than .001 psi (.02" water)

Repeatability

± .002 psi (+ .05" water)

Accuracy

± .007 psi (+ 0.2" water)

Temperature Range

30° F to 300° F/-1° C to 149° C

Burst Pressure

Titanium Diaphragm - Better than 100 psid (positive or reverse differential). Refers to maximum pressure differential applied to diaphragm.

Silicone Rubber Diaphragm - Better than 6.0 psid (positive or reverse differential).

Pressure Range

Integral electronic transmitter (868 D/P Sensor Control) provides 4-20 mA dc proportional two wire output. Pressure ranges available: 0-5, -10, -15, -30, -50 psid.

Sensor is a 1:1 pneumatic force balance diaphragm capable of repeating hydrostatic pressure as an equivalent pneumatic output. Maximum measurement pressure is determined by compressed air supply pressure (35 psi min. to 150 psi max.) minus 20 psi.

Total air consumption of sensor package (including 860-series Sensor Control) is less than 10 CFH.

** Accuracy stated applies to temperature range of 30° F to 150° F/-1° C to 66° C. Total accuracy of complete system with indicator will vary based on component selections.*

Dimensions -

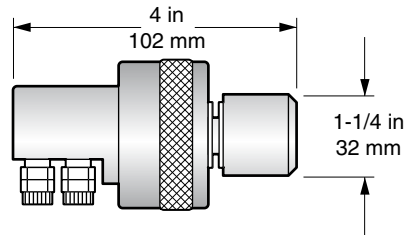

Short Length - Not generally recommended for new applications; fits King short shell

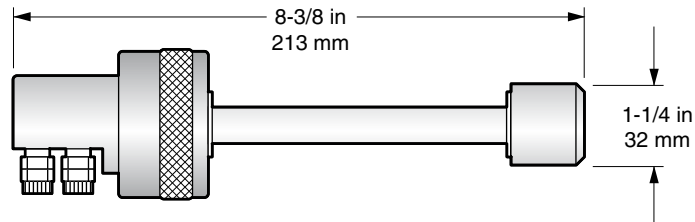

Standard Length - For single wall or insulated wall (up to 4.5"); also fits adaptors for non-King "short" shells

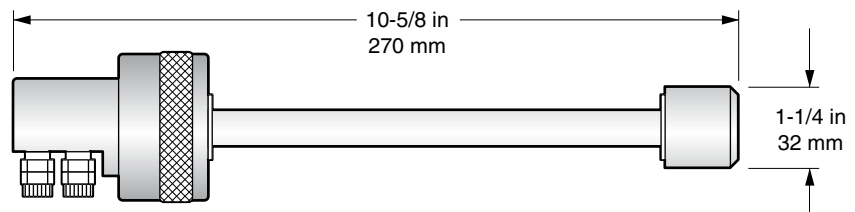

Long Length - For Crepaco silo or other thicker wall (up to 6.75") vessels; also fits adaptors for non-King standard (insulated wall) shells

AcraSensor - Metal Diaphragm Unit

AcraSensor utilizes a titanium diaphragm that is laser-fused to the sensor probe. **Figure 1** shows exploded view of typical sensor assembly. Missing or damaged O-rings will affect the performance of the sensor and should be replaced as required.

Detail 1 shows connector with port designations for tubing connections to Sensor Control (see pages 8-9).

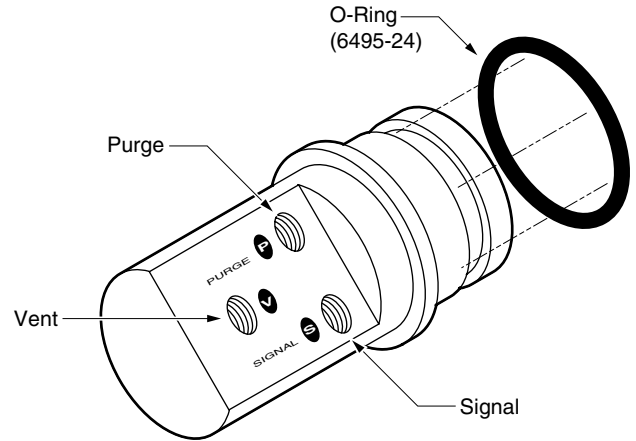

Detail 1 - Connector

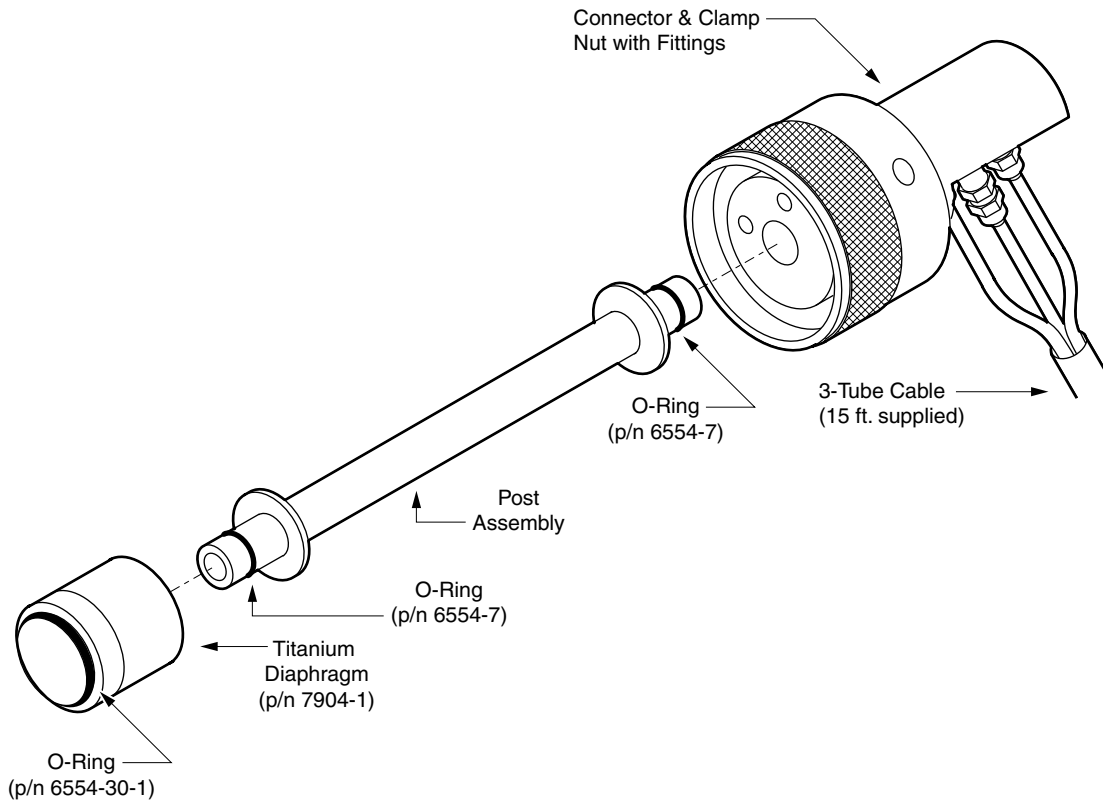
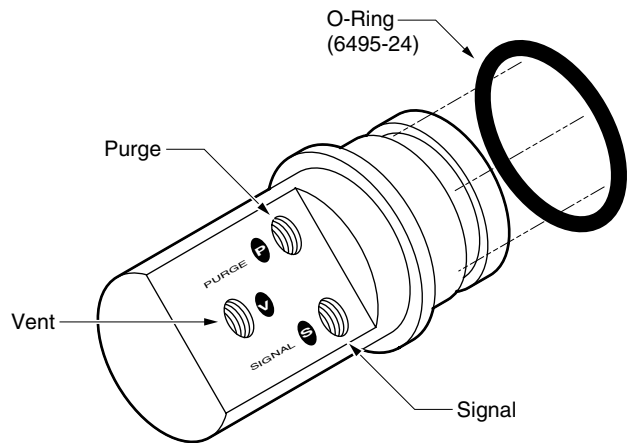

Figure 1 - Exploded view of typical sensor

AcraSensor - Silicone Rubber or Buna-N Diaphragm Unit

AcraSensor uses a molded silicone rubber (or buna-N) diaphragm that is installed onto end of probe. **Figure 2** shows exploded view of typical sensor assembly. Missing or damaged O-rings may affect the performance of the sensor and should be replaced as required.

Detail 1 shows connector with port designations for tubing connections to Sensor Control (see pages 8-9).



Detail 1 - Connector

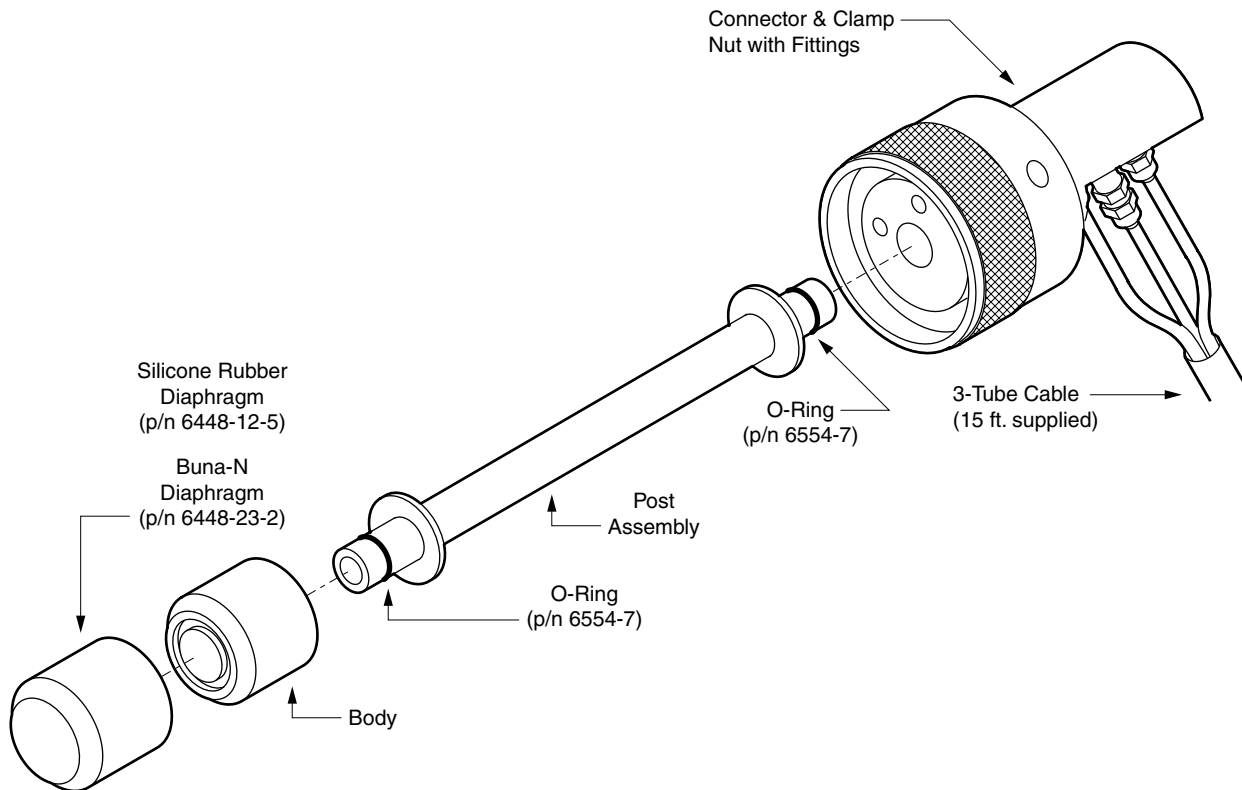
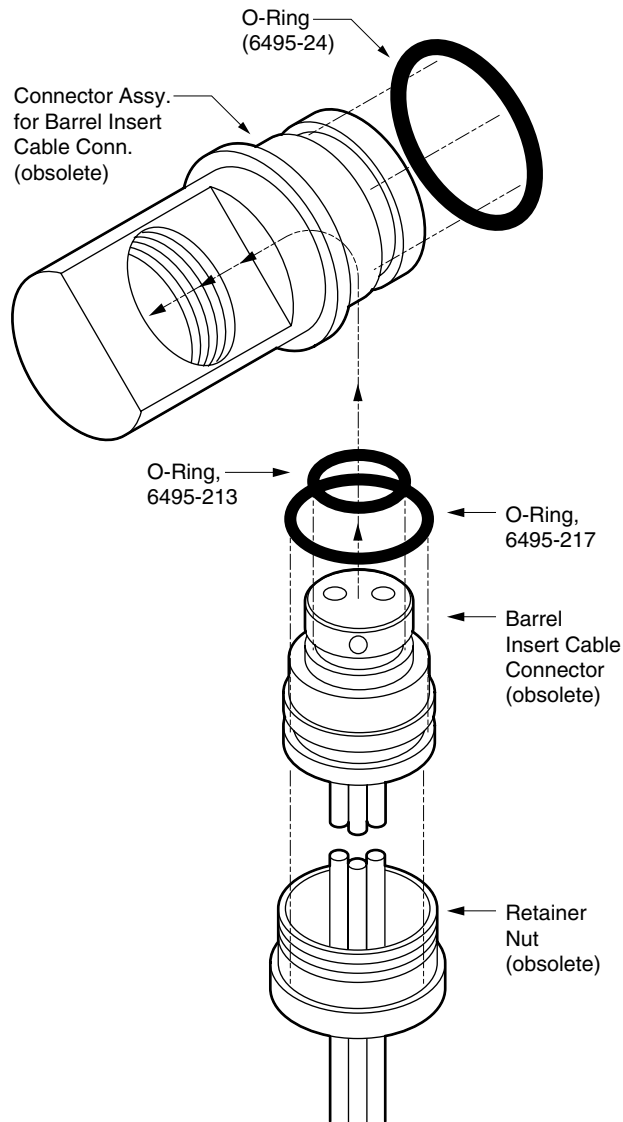

Figure 2 - Exploded view of typical sensor

Connector Assembly with Barrel Insert Cable Connector

Older versions of the AcraSensor have a "barrel insert" cable connector instead of three individual tube fittings (**Detail 2**). Other than the O-ring seals, service parts for that cable connector are not available. Replace with current connector assembly p/n 1752-22-3.



Detail 2 - Barrel Insert Connector

Complete Sensor Package - Pneumatic Output

AcraSensor pneumatic diaphragm sensors are used in conjunction with a Sensor Control. A compressed air supply must be connected to the Sensor Control for operation of the pneumatic sensor. The 3-tube interconnecting cable between the sensor at the tank and the control unit must be leak-tight. Even a slight leak at one of the tube fittings can affect the pneumatic output from the sensor.

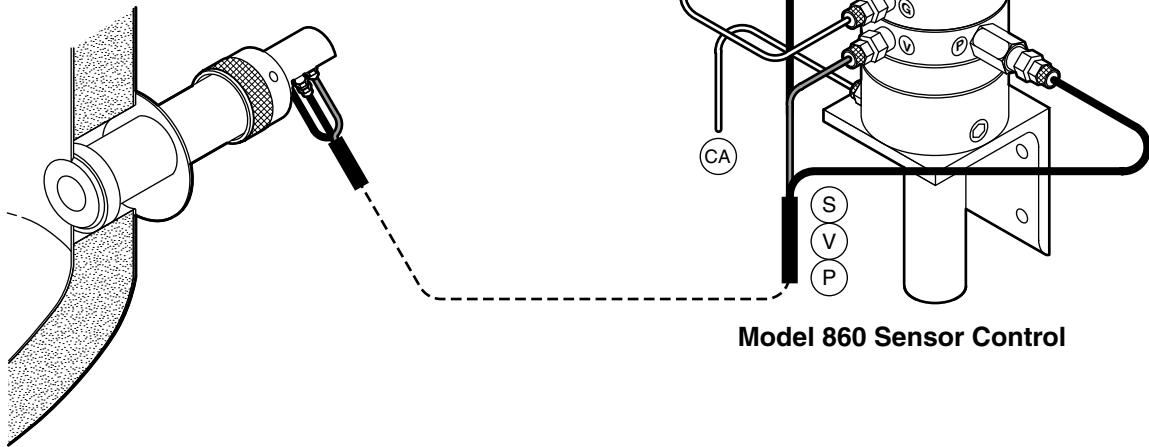

Model 860 Sensor Control

SafeGard Option

Sensor Control may include an output pressure limit control (SafeGard) to protect manometer type indicator from being overpressured. The control can be manually adjusted to either raise or lower the maximum pressure output to the indicator. If adjusted too low, it may prevent the full signal pressure from being transmitted to the indicator.

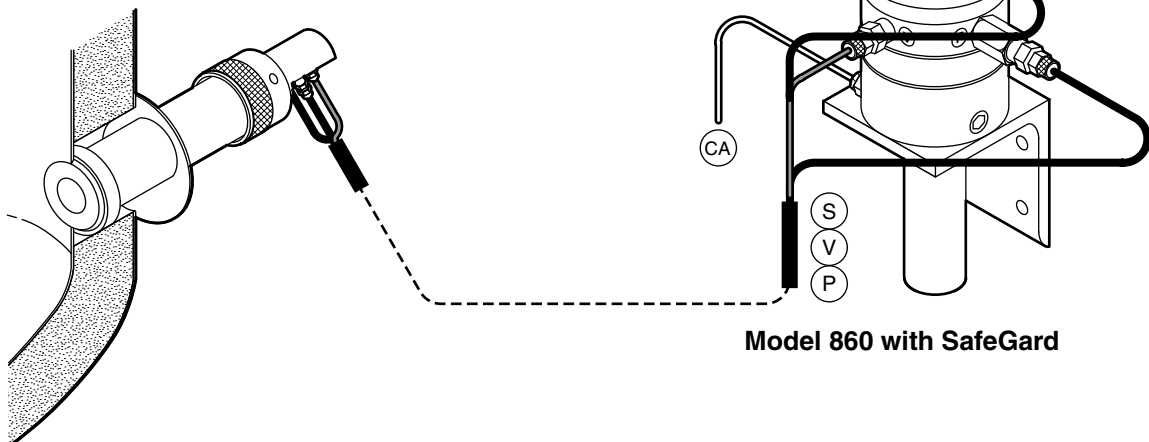

Model 860 with SafeGard

Complete Sensor Package - Electronic 4-20 mA Output

AcraSensor pneumatic diaphragm sensors can also be used in conjunction with a D/P Sensor Control to provide a direct 4-20 milliamp signal for process control or remote level indication. A compressed air supply must be connected to the D/P Sensor Control for operation of the pneumatic sensor. The 3-tube interconnecting cable between the sensor at the tank and the control unit must be leak-tight. Even a slight leak at one of the tube fittings can affect the accuracy of the output signal.

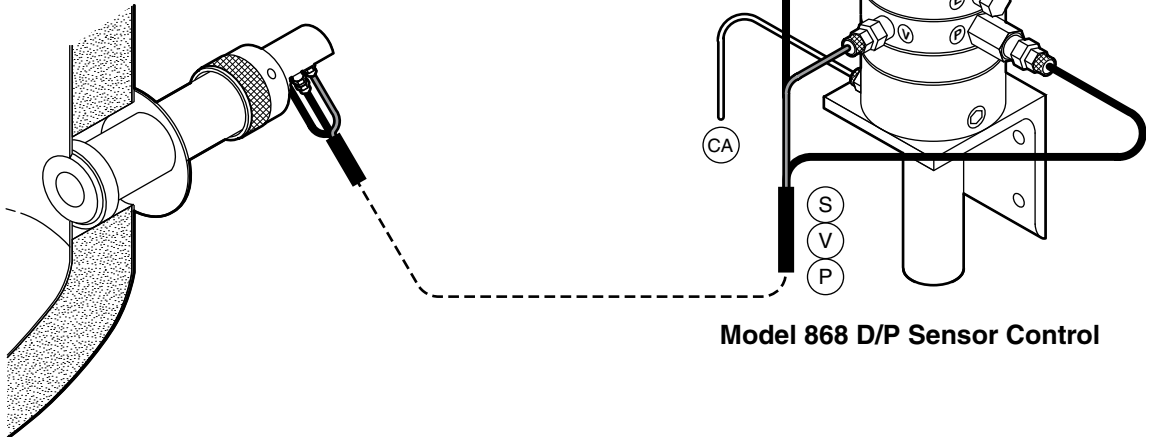

Model 868 D/P Sensor Control

Using a Manometer Type Gauge -

A tee fitting can be substituted at the "S" port of the D/P Sensor Control so that the pressure signal can be routed to a pneumatic King-Gage column indicator.

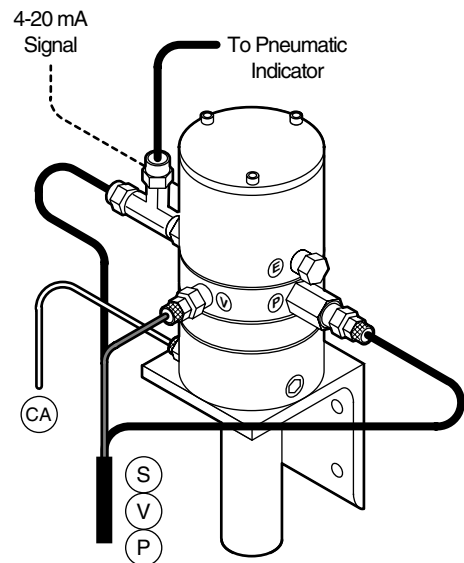

Model 868 with Tee Fitting

Preliminary - Operational Requirements

■ Compressed Air Supply

Make certain that air supply to Sensor Control is turned on. Also check that supply pressure is set to a minimum of 35 psig. The supply line must provide clean, dry and oil-free air to the Sensor Control. ***This equipment must not be used in conjunction with an in-line lubricator***, since even clean oil will foul the internal flow orifices of the Sensor Control.

Sensor Controls have a maximum allowable inlet pressure of 150 psig. Under no circumstances should this maximum pressure rating be exceeded.

Calculating minimum supply pressure required To determine the supply pressure required for proper operation of the AcraSensor/AcraSensor system, refer to the following calculation:

$$(\text{inches depth} \times \text{sp. gravity} \times .0361) + 20 = \text{psig}^*$$

*Actual minimum supply pressure should be the resulting value from the above calculation, or 35 psig, whichever is greater.

■ Tubing Connections

Check that the 3-tube cable has been properly connected to the Sensor Control and AcraSensor diaphragm unit. The individual tubes should be interconnected between similarly designated ports:

Sensor Control	AcraSensor
"P" (purge air).....	"P" (purge inlet)
"V" (vent).....	"V" (exhaust vent)
"S" (pressure signal).....	"S" (pressure signal)

Unless a D/P Sensor Control with 4-20 mA output is used, a gauge pressure connection ("G") is provided for routing the pneumatic signal to an appropriate indicator. (The 4-20 mA output of a D/P Sensor Control is transmitted over a twisted two conductor electrical cable.)

Troubleshooting Checklist

The following listing outlines some basic troubleshooting procedures to follow when the sensor does not operate or inaccurate operation is suspected.

More detailed troubleshooting procedures are covered in following sections of this manual.

■ No Output Signal

Check that compressed air supply is turned on and 3-tube cable has been connected at both the sensor and control unit.

D/P Sensor Controls Only - check that signal loop wiring has been connected to transmitter and the indicator (or other source of Vdc electrical power.)

■ Low Output Signal

Check that Sensor Control air supply pressure is set properly. Refer to "**Operational Requirements**" on this page for supply pressure guidelines. Other possibilities include leaks in system tubing or at connections between AcraSensor and Sensor Control unit.

D/P Sensor Controls Only - check that ZERO output of transmitter is 4.00 mA. If necessary, adjust transmitter (refer to transmitter manual). Other causes include high load resistance on the signal loop exceeding the capacity of the power supply. If practical, measure loop resistance if above 700 ohms power supply voltage must be increased.

■ High Output Signal

Possible restriction in vent tube or internal vent of Sensor Control. Disconnect tube at Sensor Control "V" port - if output signal decreases, Sensor Control should be serviced. If no effect on output signal, check length of tube for kinks, or evidence of liquid contamination.

Other causes may include: Venting capacity of tank is exceeded by rapid fill rate (tank vent must be open and unobstructed - dirt screens may restrict venting capacity). Tank agitation may be forcing product against sensor diaphragm. To check, stop agitation and check if sensor output signal changes.

D/P Sensor Controls Only - check ZERO and SPAN settings of transmitter. If ZERO or SPAN settings are too low, milliamp output will be elevated (refer to transmitter manual for procedures.)

■ Product Leakage

Diaphragm may be ruptured due to physical damage, exposure to incompatible chemicals, or restriction in sensor vent line. Inadequate seal within shell or adapter may be due to damaged O-rings or inadequate clamping torque. (If tank shell was recently installed, excessive grinding of weld area may have oversized the hole so that seal cannot be achieved - consult factory.)

Detailed Troubleshooting Procedures

When the gauging system is not functioning properly, the individual components should be isolated and tested separately. However, the first step should be to check that system components have been properly installed and all connections (pneumatic tubing/electrical wiring) have been completed.

■ Symptom No. 1 - High Reading (tank is known to be empty)

This condition is defined as having a slight reading of product present in the tank, even though tank is known to be completely empty. This may also be referred to as a high "air-on" reading.

- 1-1. Check for vent restriction by removing tube from "V" port of the Sensor Control. If the reading drops, this may indicate a restriction within the backpressure regulator, or perhaps that the small vent hole at the rear of the control is obstructed. (Under normal operating conditions, removing the vent tube may cause a noticeable rise in the readings on a column indicator or digital indicator.)
- 1-2. If the vent tube is disconnected, check for signs of moisture (tank product or condensation). Even a slight amount of liquid can cause restriction within the vent tube. If present, determine whether it is due to product leakage (broken diaphragm) or condensation from the air supply (install a compressed air dryer upstream of the control).
- 1-3. Creases on the face of the metal diaphragm, or poor soft diaphragm installation can create a restriction at the sensor probe face. This inhibits exhaust air flow through the vent nozzle creating backpressure and may only be readily apparent at "air-on" or lower tank depths. (Vent nozzle is located within the metal diaphragm capsule or on the body and post assembly when using soft rubber diaphragm unit.)
- 1-4. Excessive air flow from Sensor Control (over 2 CFH) will produce visibly higher "air-on" and possibly create a pressure bias affecting the output signal at all times. Check for air flow using a rotameter connected to the "P" purge port of the control (specified nominal flow is 0.8 to 1.2 CFH). Also check that the compressed air supply pressure connected to the "CA" port does not exceed 150 psig. (Air Control Section of the Sensor Control may require service and replacement parts.)
- 1-5. **D/P Sensor Controls Only** - Check "zero" output of D/P transmitter portion of Sensor Control.
- 1-6. Check column type indicator by disconnecting signal line. Indicating liquid should rest at bottom mark on scale. Too much indicating liquid will result in a slightly high reading.

Digital indicator normally displays a "reserve" value (corresponding to the capacity of the tank below the sensor). Even when tank is completely empty the reserve will normally be displayed.

Typical "Air-On" Values for AcraSensor Units

The "air-on" value refers to slight pressure output of the sensor and control even when tank is empty or liquid level is below the sensor diaphragm.

AcraSensor (metal diaphragm) with 860-Series Sensor Control:less than 0.2" inches water

■ Symptom No. 2 - Negative Reading (Tank Empty)

This condition is defined as having a slight negative pressure (vacuum). Tank is empty but is not internally subject to vacuum or sub atmospheric pressure.

- 2-1. Check that tubing from indicator is connected to the "G" port. If this line is connected to the "V" port of an 860-Series Sensor Control, the internal vent generator will create a vacuum in the gauge line.
- 2-2. The AcraSensor metal diaphragm may be physically damaged or distorted. Inspect diaphragm for creases or indentations that could inhibit the function of the internal vent nozzle. If the diaphragm has been exposed to high pressure (100 psig or greater) it may appear to be "ballooned" outward. This will also prevent the diaphragm from sealing against the internal vent nozzle.

It is also possible that product or condensation has entered the metal diaphragm capsule. While it may appear to be dry, it is possible that the liquid has evaporated leaving behind some small particles that interfere with the sealing of the vent. In any case, replace the diaphragm to see if this corrects the situation.

Additionally, the Sensor Control should be checked for air flow from the "P" purge port. Normal air flow is approximately 1 CFH. Partial blockage of the internal flow orifice coupled with contamination of the diaphragm capsule can result in a slight vacuum being pulled on the underside of the diaphragm.

Product or Liquid Contamination - Whenever contamination by product leakage or condensation from an inadequately dry or unfiltered compressed air supply is suspected, complete disassembly of the sensor control is recommended. In addition, the AcraSensor metal diaphragm capsule should be replaced since residual particles can cause continued poor performance. Do not attempt to clean the metal diaphragm capsule by soaking it in any type of solvent or cleaning solution.

■ Symptom No. 3 - Negative Reading (tank partially or completely full)

This condition is defined as having a negative reading (or "EEEE09" display on digital indicator).

- 3-1. Check that tubing from indicator is connected to the "G" gauge port of the Sensor Control. If this line is connected to the "V" vent port of an 860-Series Sensor Control, the internal vent generator will create a vacuum in the gauge line.
- 3-2. Non-Vented Tank (Differential Pressure Measurement) - check that the high and low pressure signals are properly connected to the indicator. High pressure (signal from lower sensor) and low pressure (signal from "equalizer" or upper sensor) could be reversed causing a negative reading.

■ Symptom No. 4 - High Reading (tank empty or full)

This condition is defined as having consistently high readings, regardless of whether tank is empty, partially or completely full.

- 4-1. Manometer (fluid filled) Gauge - Check column type indicator by disconnecting signal line. Indicating liquid should rest at bottom mark on scale. Too much indicating liquid will result in a consistently high reading.
- 4-2. Tank dimensions or calibration data used to make scales (column indicator) or datapack (digital indicator) may not have been accurate. Also, note whether pitch of tank has been changed as this can affect accuracy (since the actual capacity curve will be changed from that for which the scale/datapack was made). Another possibility is the specific gravity of tank product is heavier than value used to calculate scale/datapack.

Check column type indicator (if applicable) and determine whether indicating liquid is same as noted on side of scale.
- 4-3. Check for liquid in tubing between AcraSensor and Sensor Control.
- 4-4. Possible restriction in vent tube or malfunction of backpressure regulator within Sensor Control. Disconnect vent tube at "V" vent port of Sensor Control. If reading drops, restriction exists within control. If reading remains high, check for kinks in the tubing run.
- 4-5. Tank may not be adequately vented to atmosphere. (Tanks that are heated may create elevated internal pressure if vents are closed or restricted.) If tank is closed, pressurized or inadequately vented to atmosphere, an equalizer must be installed for measuring differential pressure.
- 4-6. D/P Transmitter or D/P Sensor Control - Check zero adjustment of transmitter with empty tank and sensor output at "air-on". Reset zero to 4.00 mA if necessary.

- 4-7. Older-Style Barrel Insert Connector - If AcraSensor uses older barrel insert type connector (see page 7) one of the O-ring seals may be missing or damaged. Check barrel insert and inspect O-ring seals. Replace any O-ring that is cut or extremely worn.
- 4-8. If the tank has an agitator, the sensor may be affected by product flow across the face of the diaphragm creating a high reading. Turn off agitator and check if reading drops.
- 4-9. Excess air flow from "P" purge port of Sensor Control. Use a rotameter connected to the control to measure actual flow rate. Flow above 2 CFH will cause noticeably high readings. (Specified nominal flow rate is 0.8 to 1.2 CFH)

Note: A common cause of excess flow is due to bad O-ring seal on the internal flow orifice of the Sensor Control. Another cause results from enlargement due to attempted cleaning of the orifice using a wire or pin. The diameter of the orifice is critical in producing the desired 1 CFH flow rate.

Additional Notes Regarding Inaccurate Readings -

King-Gage Column Type Indicators - The indicating liquid used must be the same as is noted on the indicator scale. These liquids are color-coded as to their specific gravity. Using the wrong specific gravity liquid will create inaccurate readings.

King-Gage Digital Indicators - The Personality Datapack (preprogrammed tank capacity file configured as a PROM) must be installed in the digital indicator. The Datapack can be used only to gauge the specific tank for which it was programmed. Always make certain that Datapack(s) are installed in the appropriate indicator.

LevelBAR Electronic Indicators - The indicator reference voltage setting must correspond to the value noted on the scale. Make certain that indicator is properly set. Misadjustment can elevate or depress zero and/or span. Refer to LevelBAR manual for detailed REF HI, REF LO settings discussion.

■ Symptom No. 5 - Low or No Reading (tank partially or completely full)

This condition is defined as having low readings, or even no reading when tank contains product. No reading, however, does assume that compressed air supply is turned on at Sensor Control.

- 5-1. Check that all tubing is connected at AcraSensor and Sensor Control. Also check tubing and connections for leaks. Small leaks may cause low readings only at upper levels in the tank. Generally, it is best to look for leaks when tank is completely full and system is fully pressurized.

Older-Style Barrel Insert Connector - If AcraSensor uses older barrel insert type connector (see page 7) one of the O-ring seals may be missing or damaged. Check barrel insert and inspect O-ring seals. Replace any O-ring that is cut or extremely worn.

- 5-2. If Sensor Control includes a SafeGard, it is possible that the pressure setting is not correctly adjusted. When no reading exists, the SafeGard may be set so low that virtually no signal pressure is going to the indicator. If readings stop suddenly, even though tank level continues to increase, the SafeGard setting is too low.
- 5-3. If readings are consistently low, it could be that the tank contains a lighter specific gravity product than was calculated for the indicator. If incorrect capacity data was furnished, this would result in inaccurate (low) readings.

Also note whether tank pitch has been changed as this can affect accuracy (since the actual capacity curve will be changed from that for which the scale/datapack was made).

- 5-4. Column type indicator (if applicable) - Determine whether indicating liquid is same as noted on side of scale.

Also check to see if vent plug is correctly installed at top of glass tube. If equipped with Overflow Check Valve, remove and observe gauge reading. If reading rises, check valve may be sealed shut. Inspect for proper operation by shaking. The internal float element should rattle audibly if operational. If no rattle is heard, check valve may need to be serviced or replaced.

Overflow Check Valve - King-Gage column indicators are often equipped with a float-type check valve to prevent indicating liquid from escaping out the top of the glass tube during overpressure (overrange) conditions. Indicating liquid may contaminate float and inhibit proper operation of check valve, affecting operation of manometer type gauge.

- 5-5. D/P Transmitter or D/P Sensor Control - check zero adjustment of transmitter with empty tank and sensor output at "air-on". Reset zero to 4.00 mA if necessary.

If there is no output from D/P transmitter, check that signal wiring has been properly connected to "+" and "-" terminals. (If reversed, no electrical current will flow through transmitter.) Also check that signal loop wiring is hooked up to source of DC electrical power.

- 5-6. If the tank has an agitator, the sensor may be affected by product flow across the face of the diaphragm creating a pressure drop. Turn off agitator and check if reading rises.
- 5-7. If low readings occur only at upper tank levels, compressed air supply pressure may be set too low. (Refer to page 10 for supply pressure requirements.)
- 5-8. Improperly installed soft rubber diaphragm can be a possible cause of low readings. Check that molded diaphragm is evenly mounted on end of body and post assembly.

AcraSensor Metal Diaphragm - Check diaphragm face for creases or distorted appearance which may affect function of the internal vent nozzle. If the diaphragm has been exposed to high pressure (100 psig or greater), it may appear to be "ballooned" outward.

- 5-9. It is possible that product or condensation has contaminated metal diaphragm capsule. While it may appear dry, it is possible that liquid has evaporated leaving behind some small particles that interfere with the sealing of the vent nozzle. Replace diaphragm and see whether this corrects the situation.

5-10. Check Sensor Control air flow from "P" purge port. Normal air flow is approximately 1 CFH. Partial blockage of the internal flow orifice can reduce air flow to sensor resulting in low readings.

5-11. Check for signs of liquid in tubing between AcraSensor and Sensor Control. Also inspect tubing run to indicator (if applicable) for kinks or liquid contamination.

■ Symptom No. 6 - Reading Stops Rising While Tank is Being Filled

This condition is defined as having normal readings at lower levels in the tank. However, at some point readings stop rising even though tank level increases as filling continues.

6-1. If Sensor Control includes a SafeGard, it may be adjusted too low. This will cutoff gauge signal as the pressure increases. Check SafeGard pressure setting and adjust upward if necessary.

6-2. Check all tubing and connections for leaks. Some leaks may only occur at upper tank levels when pressure is higher. If possible, leak-check system when this condition occurs.

6-3. Compressed air supply pressure may be too low to balance liquid head. (Supply pressure should be at least 20 psig greater than liquid head pressure. Refer to page 10 for supply pressure requirements.)

6-4. Digital Indicators - If reading stops increasing and letter "H" appears on left side of display, top calculated value has been reached. If indicator displays "EEEE09", the signal applied exceeds range of indicator. This may be due to fact that liquid product has heavier specific gravity than that which was used to calculate the datapack.

Always check that datapack is installed in correct digital indicator (or proper mounting socket in expansion chassis on multiple tank digital indicators).

6-5. Column Indicators - Check that vent plug is installed at top of glass tube. If equipped with Overflow Check Valve, remove and inspect for contamination or malfunction. (When shaken, the internal float should rattle audibly if functional.)

6-6. Check that clamp ring on AcraSensor is securely tightened. Another possibility is that sensor diaphragm has a small hole permitting air to leak only at higher pressures when liquid depth is near top of tank.

■ Symptom No. 7 - Overpressure Condition (Overrange Signal)

This condition is defined as pressure signal exceeding range of indicator (or D/P transmitter, if applicable).

7-1. Tank product is of a higher specific gravity than was originally calculated. This will result in higher pressure signals which may exceed the range of the indicator.

7-2. Possible restriction or blockage of vent tube. Also, possible malfunction of backpressure regulator within Sensor Control prevents venting of excess air from AcraSensor. It may also be caused by a plugged vent hole on rear of Sensor Control.

7-3. Tubing is improperly connected at Sensor Control. If gauge line is mistakenly connected to "P" purge port of control, signal to gauge may go to full line pressure.

7-4. D/P Transmitter or D/P Sensor Control - If wrong range of transmitter was ordered, pressure output of AcraSensor may exceed full scale of transmitter. If transmitter output exceeds 20.00 mA, indicator may display "EEEE09" (overrange).

7-5. Closed or inadequate vent on tank may create internal pressure above liquid product when tank is being rapidly filled. Check that tank vent is clear and unobstructed.

7-6. Non-Vented (Differential Pressure) Application - If upper sensor is disconnected or low pressure input at indicator is disconnected, unequalized high pressure signal may exceed range of indicator.

If low pressure input at D/P Transmitter or D/P Sensor Control is disconnected, unequalized high pressure signal may exceed range of transmitter.

■ Symptom No. 8 - Fluctuating or Bouncing Readings

This condition is defined as having severely unstable readings. It may also be manifested by “bouncing” (e.g. rapid variations between high and low readings).

- 8-1. Sensor may be affected by tank agitator (if applicable). Turn off agitator and observe if reading stabilizes.
- 8-2. Possible liquid or product in tubing between AcraSensor and Sensor Control. If a small amount of liquid collects at a bend in the tubing, it may create pressure fluctuations. (Inspect vent tube and signal tubing for possible liquid accumulation.)

Recurring evidence of moisture (not tank product) is generally condensation resulting from an inadequately dry compressed air supply. A coalescing filter and compressed air dryer may be required for installation in the main supply line.

- 8-3. Column type indicator - Check indicator to determine that indicating liquid is same type as noted on side of scale.

If small bubbles are occasionally seen within the glass tube of the indicator, there may be insufficient indicating liquid. Remove signal line from gauge and check that indicating liquid rests at lowest mark on indicator scale.

Reference Documentation

The following is a list of reference documentation available for the AcraSensor:

Part No.	Description
SP & D 1060-25.00.....	Service Parts & Dimensions - Titanium Diaphragm Units (Weld-In Mount)
SP & D 1020-25.00.....	Service Parts & Dimensions - Rubber Diaphragm (Weld-In Mount)
K-1060-1-1777.....	Installation Instructions - AcraSensor Tank Shell Welding Procedures
K-1060-1-8999.....	Installation Instructions - AcraSensor Sanitary Sensor
K-1090-1-860.....	Installation Instructions - King Sensor Control - Model 860
K-1090-1-868.....	Installation Instructions - King Sensor Control - Model 868



Box 1228, Ann Arbor, Michigan 48106-1228 U.S.A.
 Phone: (734) 662-5691 ▪ FAX: (734) 662-6652