

# Service Parts & Dimensions – 1010-12.00

Effective: October 2002 (replaces May, 1996)

## Model 3250 Multi-Tube Indicator (Carbon Steel or Stainless Steel Housing)

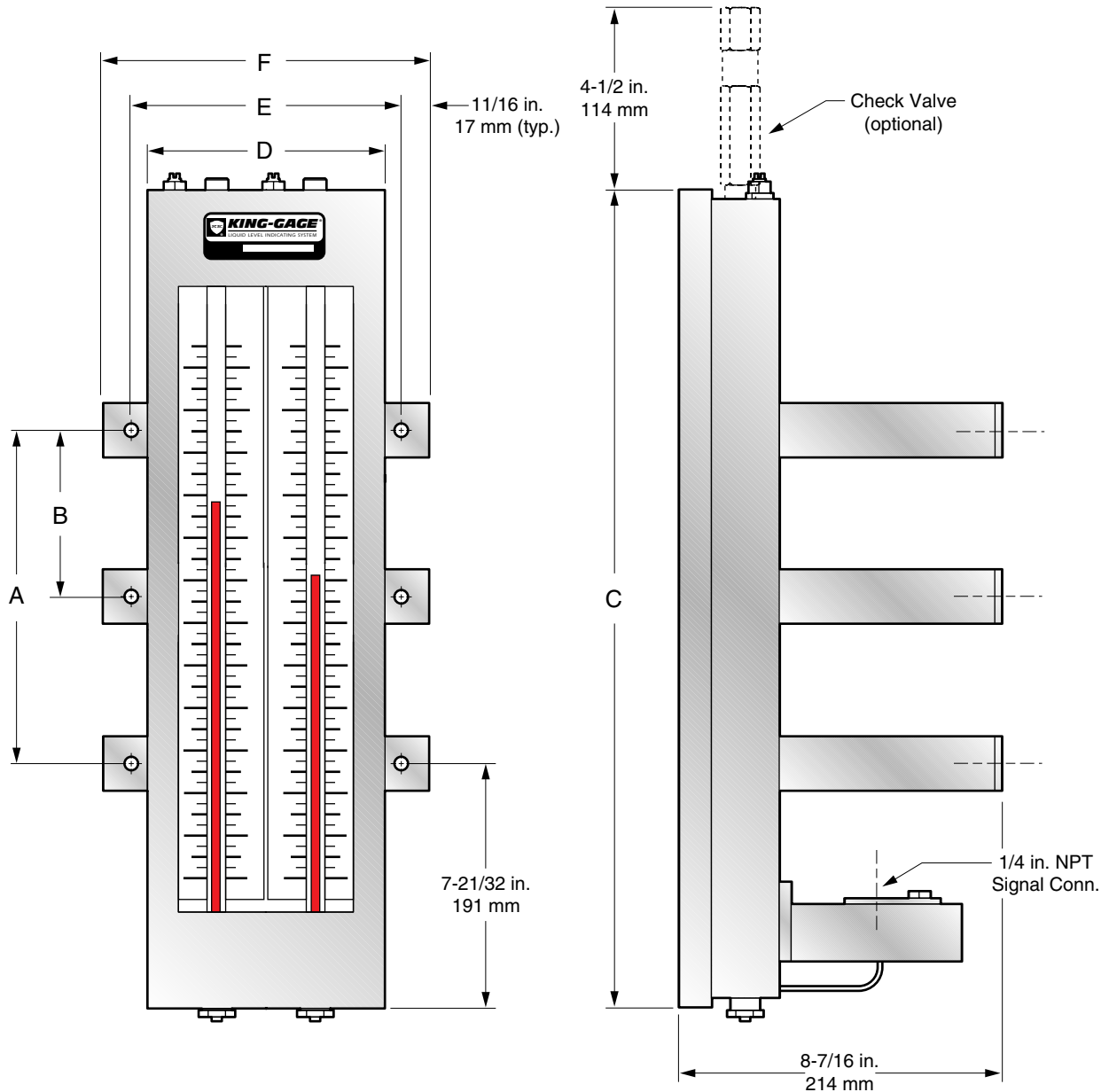

Dimensions by Indicator Range (inches)

	20 In.	30 In.	40 In.	50 In.	60 In.
Dim.					
A	10-1/2	20-1/2	30-1/2	40-1/2	50-1/2
B	-	-	-	-	27
C	25-1/2	35-1/2	45-1/2	55-1/2	65-1/2

Dimensions by Number of Tubes (inches)

	2 Tubes	4 Tubes	6 Tubes	8 Tubes	10 Tubes
Dim.					
D	5-5/8	10-1/4	14-7/8	19-1/2	24-1/8
E	6-5/16	10-15/16	15-9/16	20-3/16	24-13/16
F	7-11/16	12-5/16	16-15/16	21-9/16	26-3/16

**Model 3250 Service Parts:**

Item	Description	Part No.	Qty.	Notes
1	Vent Plug	6560	1	1
2	Glass Tube Repl. Kit	5164-x	1	1,2,3 (includes: glass tube, packing washers & O-rings)
3	Glass Tube Packing Seal Kit	5181-1	1	3 (includes: packing washers, O-rings & nuts)
4	Drain Plug	8115-4	1	1
5	Drain Plug Washer	4029-2	1	1
6	Well Tube Packing	8806	1	1
7	Indicator Well	8448-4	1	1
8	Overflow Check Valve (Optional)	8838	1	1
9	Replacement Scale	3201-1-X	1	2,6
		3201-2-X	1	2,6
10	Replacement Liquid			
	Red, No. 294	2992-x	1	4
	Purple, No. 175	9175-x	1	4
	Mercury	2604-3-1	1	5

**Notes:**

- Quantity required is determined by the number of indicating tubes. Quantity listed is per each tube.
- Dash number indicates range.
- Glass Tube Kit includes all items in Tube Packing Seal Kit.
- Dash number indicates bottle size (8 or 16 oz. bottles only).
- Sold by weight (1 lb. bottles only).
- When ordering a replacement scale, the following information must be supplied:
  - Tank Designation
  - Unit(s) of measurement
  - Scale serial number
  - Specific gravity, product density, etc.

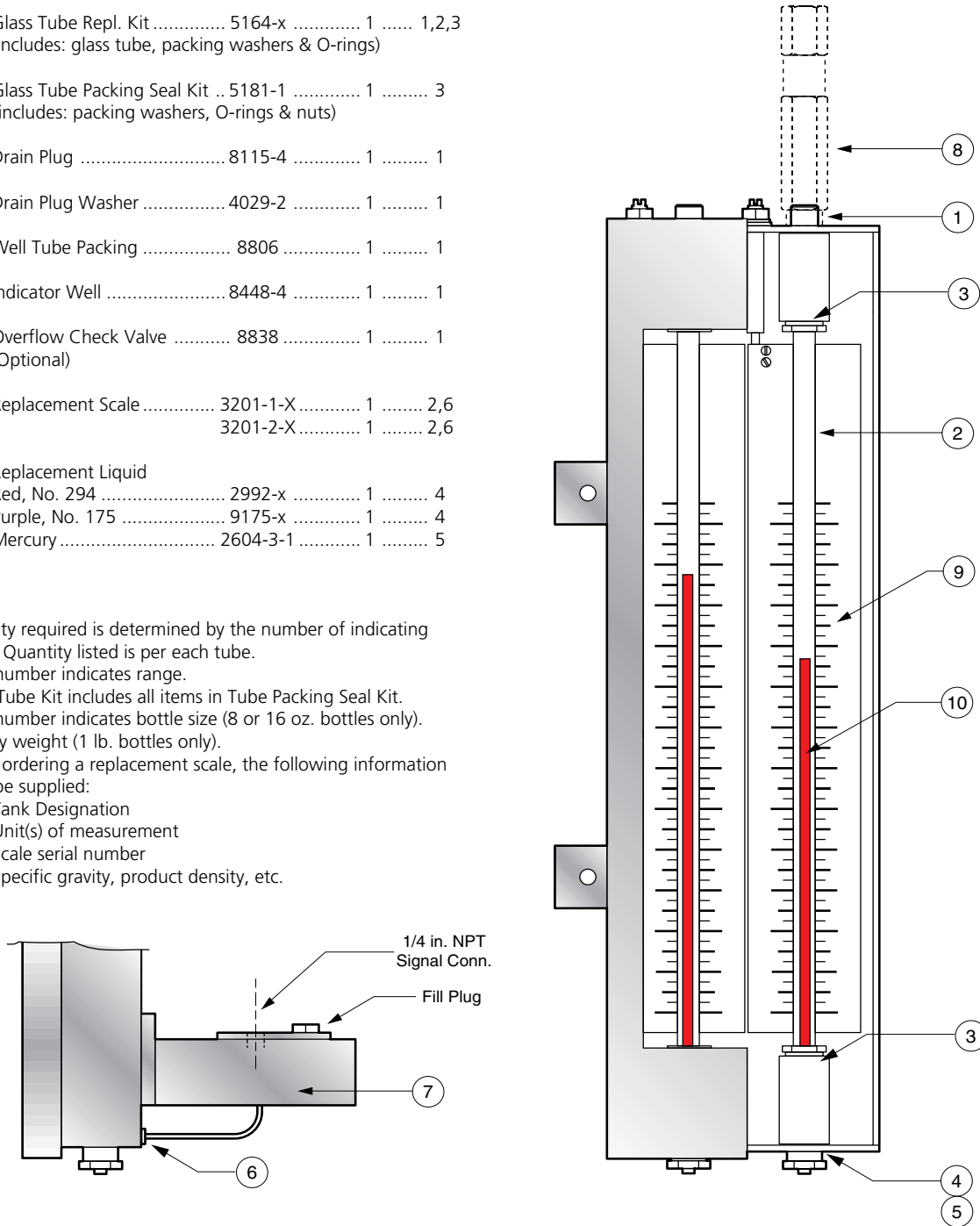

© KING-GAGE and the KE emblem are registered trademarks of King Engineering Corporation Ann Arbor, Michigan, U.S.A.

© 1996, 2002 King Engineering Corporation. All rights reserved. All specifications are subject to change without notice