



12 SCFM ultra-c™ Filters

Models:

- U122 Filter w/Manual Drain
- U123 Filter w/Automatic Drain

Rated Flow:

- 12 SCFM @ 100 psig
- 340L/min @ 7 Kg/cm²
- 20 m³/hr @ 7 bar

Max. Pressure:

150 psi

Connections:

1/2 in NPT (Input/Output)

Cartridges: Two (2) Element Design -

- 1st Stage Scrubber (coalescing)
- 2nd Stage Indicating Polisher

Physical Data:

- Housing - Aluminum/Polycarbonate
- Weight - 2 lbs.

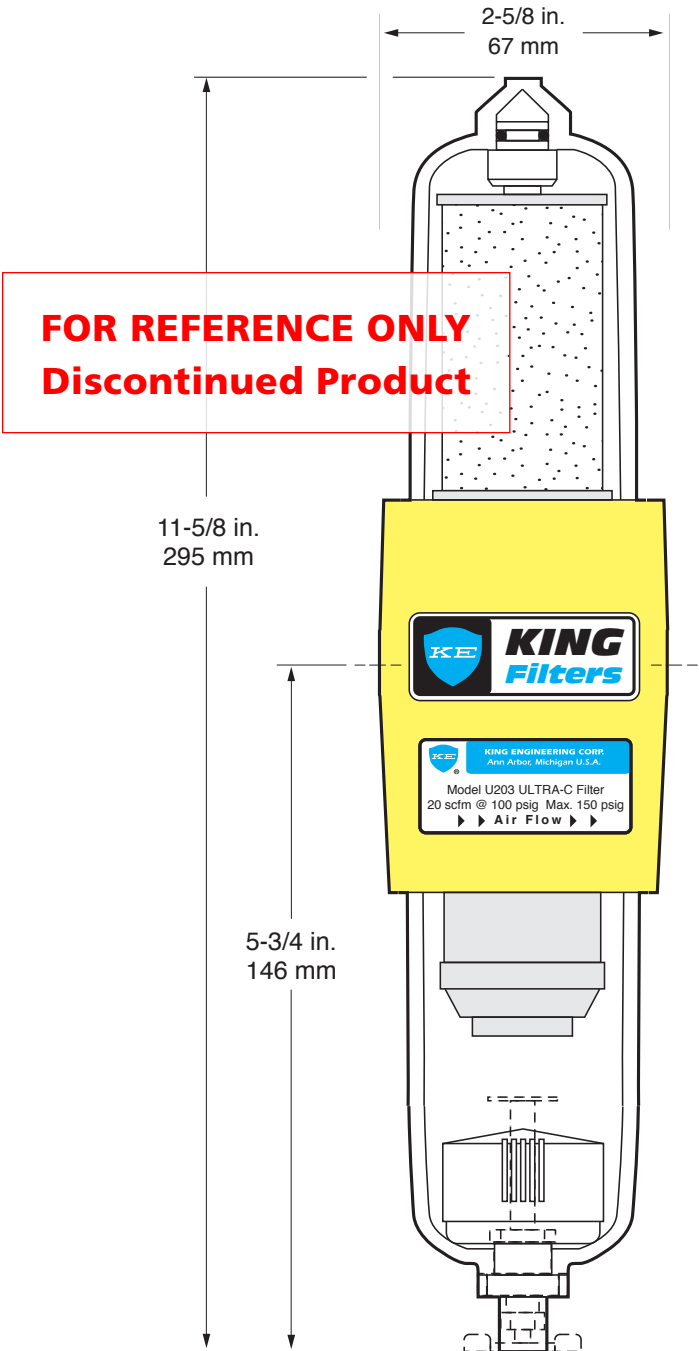

**FOR REFERENCE ONLY
Discontinued Product**

Inside:

- Installation Instructions.....page 2
- Service Parts.....page 3
- Cartridge Replacementpage 4

U122/123
Two Stage Filter
with Indicating Cartridge

Installation Instructions

Vapor and Condensation

Many types of pneumatic equipment and processes use compressed air that must be clean, dry and oil-free. This requires the removal of liquids, aerosols, dust and solid particulates from the airstream. Generally, only condensed liquids need to be removed. Visible fog or mist is actually composed of condensed liquid droplets. These are easily removed by using a coalescing compressed air filter at the end-use point.

Vapor is liquid in evaporated form. In this gaseous state, the liquid vapor will be invisible. Oil and water vapor are commonly present in compressed air systems. If either type of vapor must be removed, a compressed air dryer must be used. Desiccant dryers, for instance, use media that attracts the vapor molecules through a process called "adsorption".

Application Note

Polycarbonate Sumps/Acrylic Cases

Polycarbonate sumps and/or acrylic plastic housings will be damaged if exposed to phosphate ester (synthetic) lubricants, chlorinated hydrocarbon solvents, methanol, acetone, ketones or lacquer solvents. Continued exposure to these compounds may result in premature failure of the pressure housing. Use only metal sumps/housings in environments where these materials and/or vapors are present.

Use of metal safety guards is generally recommended in certain instances, occupational safety regulations may require the use of metal guards or metal pressure housings.

Manufacturer's warranties are void in the event of misapplication or negligence and manufacturer assumes no responsibility for loss under such circumstances.

Installation Instructions

1. Locate filter in coolest location in air system.
2. Install drip leg upstream of filter.

3. Locate filter as near end use as possible.
4. Always make inlet connection to port marked "Inlet" on the filter.
5. Auto Drain requires minimum 20 psi (1.4 kg/cm²) inlet pressure for proper operation.
6. Pressure gauges installed on both sides of the filter are useful to indicate when filter is being used in its proper flow range and also indicate when cartridges need replacing.
7. Pressure rating 150 psig. Maximum temperature when plastic bowl is used is 125° F./52° C.
8. It is important to the proper operation of the filter that the sump be drained daily. Failure to do this may cause permanent damage to equipment down-stream of the filter.

End-Use Filters

Filtering the entire compressed air system at one central location does not generally provide sufficient cleaning for all end-use applications. Moreover, most compressed air piping contains some amount of rust, scale and condensed liquids. Water vapor that may be present in warm air will tend to condense into liquid when the air cools.

A compressed air filter installed just upstream of the end-use is generally the most efficient means of ensuring clean, dry air. These end-use filters can provide clean air to meet individual process requirements. A coalescing filter should be specified due to its long service life where liquid contaminants may be encountered.

Do not undersize a compressed air filter. Exceeding the listed flow rate of the filter will have a proportionate decrease in the service life of the cartridge elements. Frequent cartridge replacement necessitated by undersizing an application significantly increases maintenance costs. Maximum efficiency is generally obtained between 15%-100% of the maximum rating.

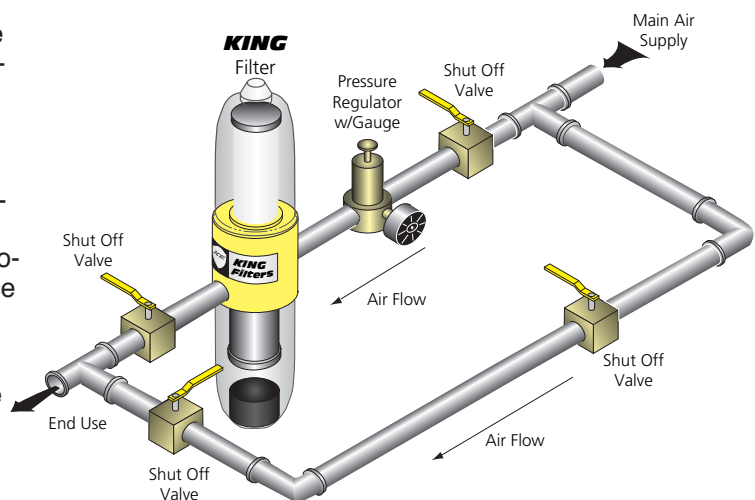

Replacement Filter Cartridges:

Model U122/U123

Lower: 1st Stage Element - U3000
(Coalescing Type)

Upper: 2nd Stage Element - U3001
(Color Change Indicating)

Item	Description	Part No.	Qty.
1	Scrubber Cartridge (note 1)	above	1
2	Color-Change Polisher (note 2)	above	1
3	Bowl Assembly (note 3)	U4002	1
4	O-Ring (note 4)	U6495-557	2
5	Sump w/Auto Drain (note 3)	4522-6	1
6	Sump w/Manual Drain (note 3)	U4001	1
7	Manual Drain	6120-4	1
8	Automatic Drain	2465-31	1
9	Mounting Bracket	U6524-163	1

Notes:

1. Includes o-ring, p/n 6495-9.
2. Includes o-ring, p/n 6495-219.
3. Includes o-ring, p/n U6495-557.
4. Included with items 3,5 & 6.

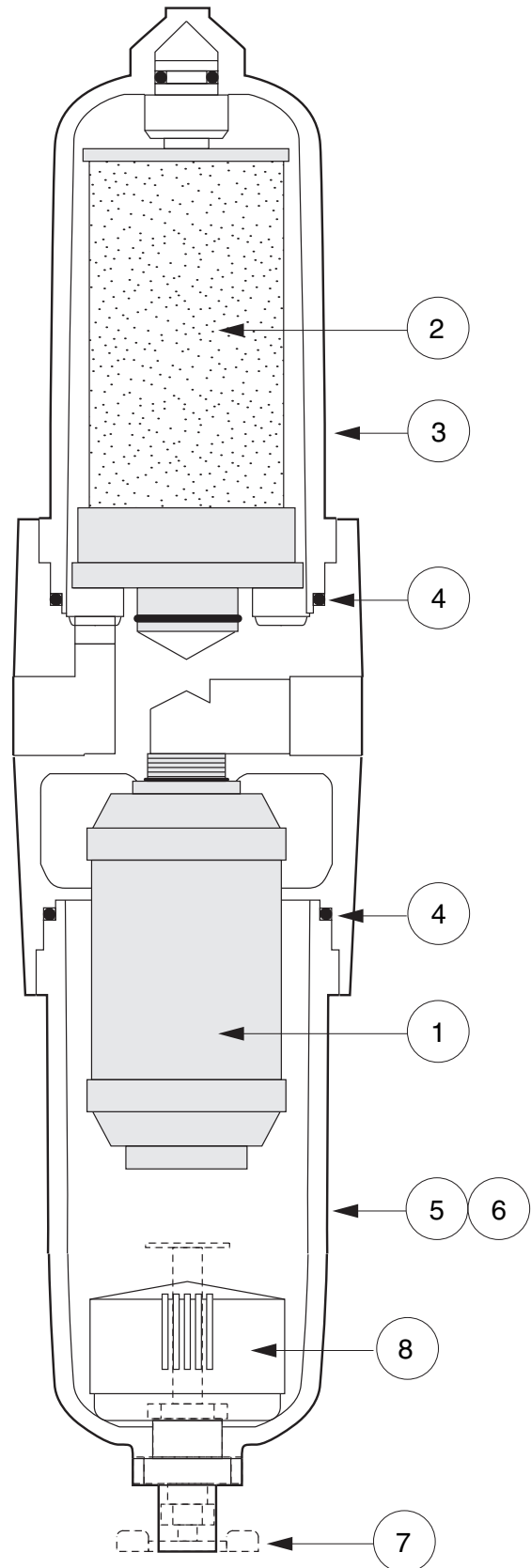

Cartridge Replacement

Under normal operating conditions, the only servicing which need be done to a King filter is to change the cartridge and indicating polisher. The number of times that this must be done will vary with each installation. Generally, the cartridges are changed when the pressure drop across the filter becomes objectionable or when the indicating polisher is pink halfway.

To change the cartridge the following procedure should be followed:

1. Turn off the air supply and drain the filter. This will vent the filter of all compressed air.
2. Remove the sump.
3. By using a King Filter utility wrench (p/n 2585) or inserting the points of long nose pliers into the two slots in the bottom of the scrubber cartridge it can be unscrewed. Install a new scrubber cartridge and replace the sump.
4. Turn on the air supply and the filter will start functioning immediately.

Instructions for Installing Indicating Polisher

1. Remove upper bowl. Remove the old polisher by grasping it with a rag, pulling straight up with a twisting motion.
2. Any contamination of bowl or filter body should be cleaned away. See below.
3. Install a new polisher by pushing down with a twisting motion until it seats firmly. A small amount of Vaseline or Neva-Stain on the o-ring may aid in installing the new polisher.
4. Replace the bowl.
5. Turn on the air supply and the filter will start functioning immediately.

To clean Polycarbonate bowls use mild soap and water only!
Do not use cleansing agents such as acetone, benzene, carbon tetrachloride, gasoline, toluene, etc., which are damaging to this plastic.

Caution! it is important to the proper operation of the filter that the sump be drained daily. Failure to do this may cause permanent damage to equipment downstream of the filter.

