



Service Parts & Dimensions

6000 - 1.03

Effective : January 1998 (replaces november, 1992)

20 SCFM Air-Guard™ Coalescing Filters

Models:

- 4525-19 Filter w/Manual Drain
- 4525-19T Filter w/Automatic Drain

Capacity:

- 20 SCFM @ 100 psig
- 566 l/min @ 7 Kg/cm²
- 34 m³/hr @ 7 bar

Max Pressure:

150psig

Connections:

1/2 in NPT

Cartridges:

- Two (2) Element Design -
- 1st Stage Scrubber (coalescing)
- 2nd Stage Polisher (adsorptive)

Physical Data:

- Housing - Aluminum/Polycarbonate
- Weight - 8lbs/3.63 kg

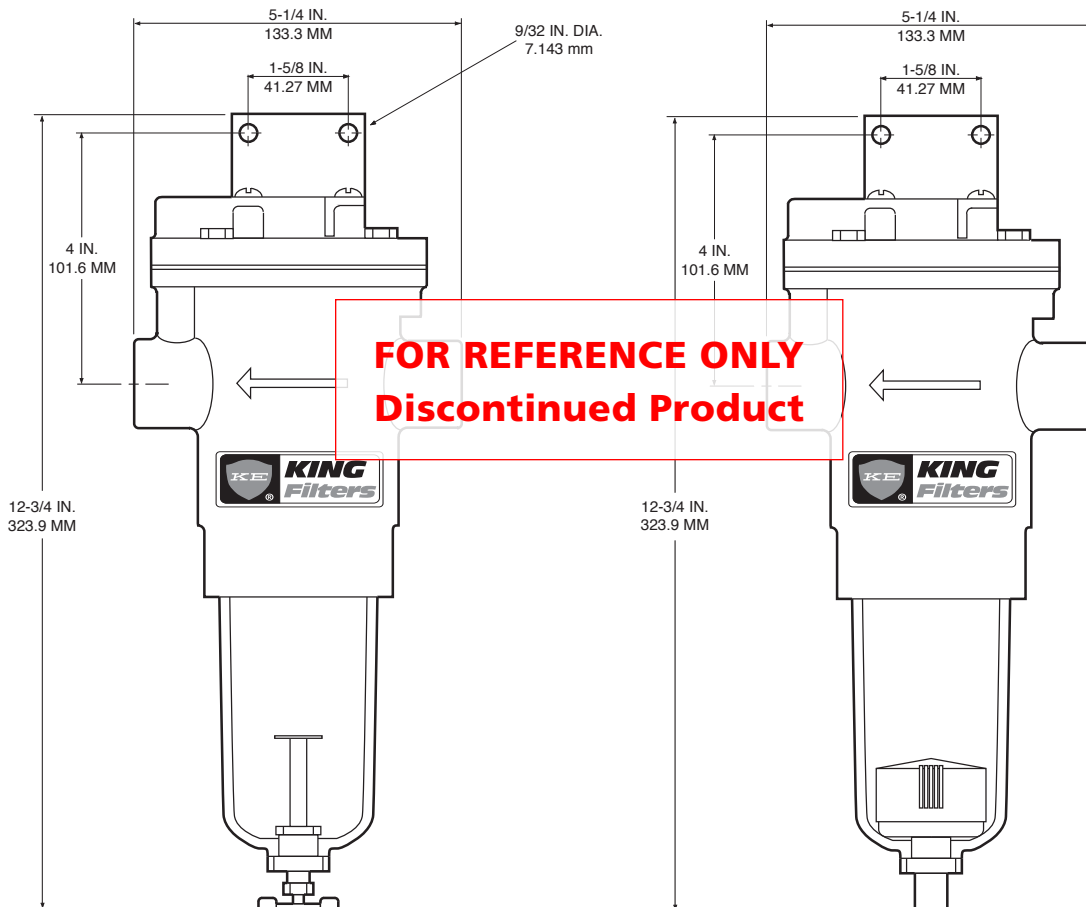

Inside:

- Installation Instructions.....page 2
- Service Parts.....page 3
- Cartridge Replacement.....page 4

Installation Instructions

End-Use Filters

Filtering the entire compressed air system at one central location does not generally provide sufficient cleaning for all end-use applications. Moreover, most compressed air piping contains some amount of rust, scale and condensed liquids. Water vapor that may be present in warm air will tend to condense into liquid when the air cools.

A compressed air filter installed just upstream of the end-use is generally the most efficient means of ensuring clean, dry air. These end-use filters can provide clean air to meet individual process requirements. A coalescing filter should be specified due to its long service life where liquid contaminants may be encountered.

Do not undersize a compressed air filter. Exceeding the listed flow rate of the filter will have a proportion-

ate decrease in the service life of the cartridge elements. Frequent cartridge replacement necessitated by undersizing an application significantly increases maintenance costs. Maximum efficiency is generally obtained between 15%-100% of the maximum rating.

Vapor and Condensation

Many types of pneumatic equipment and processes use compressed air that must be clean, dry and oil-free. This requires the removal of liquids, aerosols, dust and solid particulates from the airstream. Generally, only condensed liquids need to be removed. Visible fog or mist is actually composed of condensed liquid droplets. These are easily removed by using a coalescing compressed air filter at the end-use point.

6. Pressure gauges installed on both sides of the filter are useful to indicate when filter is being used in its proper flow range and also indicate when cartridges need replacing.

7. Pressure rating 150 psig. Maximum temperature except when plastic bowl is used is 200° F./93° C. Maximum temperature when plastic bowl is used is 125° F./52° C.

8. It is important to the proper operation of the filter that the sump be drained daily (or be equipped with auto-drain). Failure to do this may cause permanent damage to equipment down-stream of the filter.

Vapor is liquid in evaporated form. In this gaseous state, the liquid vapor will be invisible. Oil and water vapor are commonly present in compressed air systems. If either type of vapor must be removed, a compressed air dryer must be used. Desiccant dryers, for instance, use media that attracts the vapor molecules through a process called "adsorption".

Application Note

Manufacturer's warranties are void in the event of misapplication or negligence and manufacturer assumes no responsibility for loss under such circumstances.

Installation Instructions

1. Locate filter in coolest location in air system.
2. Install drip leg upstream of filter.
3. Locate filter as near end use as possible.
4. Always make inlet connection to port marked "Inlet" on the filter.
5. Auto Drain requires minimum 20 psi (1.4 kg/cm²) inlet pressure for proper operation.

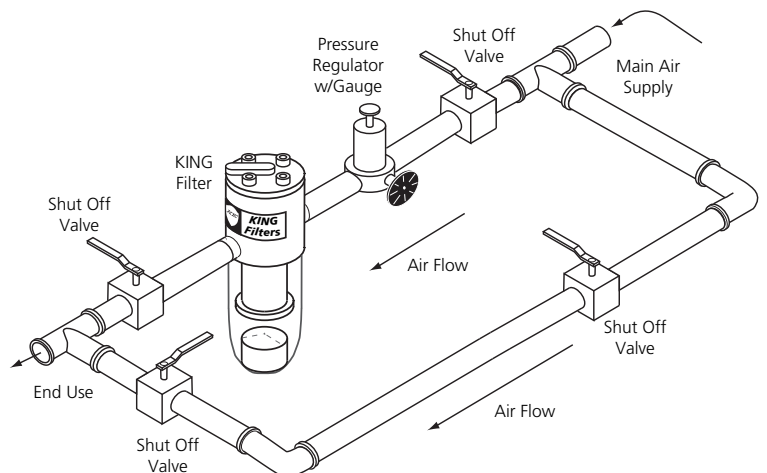

Replacement Filter Cartridges:

(Standard)

0.1 Micron Replacement Set A22-11-6-5
Type 750 Scrubber/Type 800 Polisher

Type 750 Scrubber only - Order no. 9318-80
Type 800 Polisher only - Order no. A31-1-5

(Optional)

2.0 Micron Replacement Set A22-11-1-1
Type 300 Scrubber/Type 300 Polisher

Type 300 Scrubber only - Order no. 9318
Type 300 Polisher only - Order no. A31-1-1

Note: Other cartridge grades are available.
Details upon request.

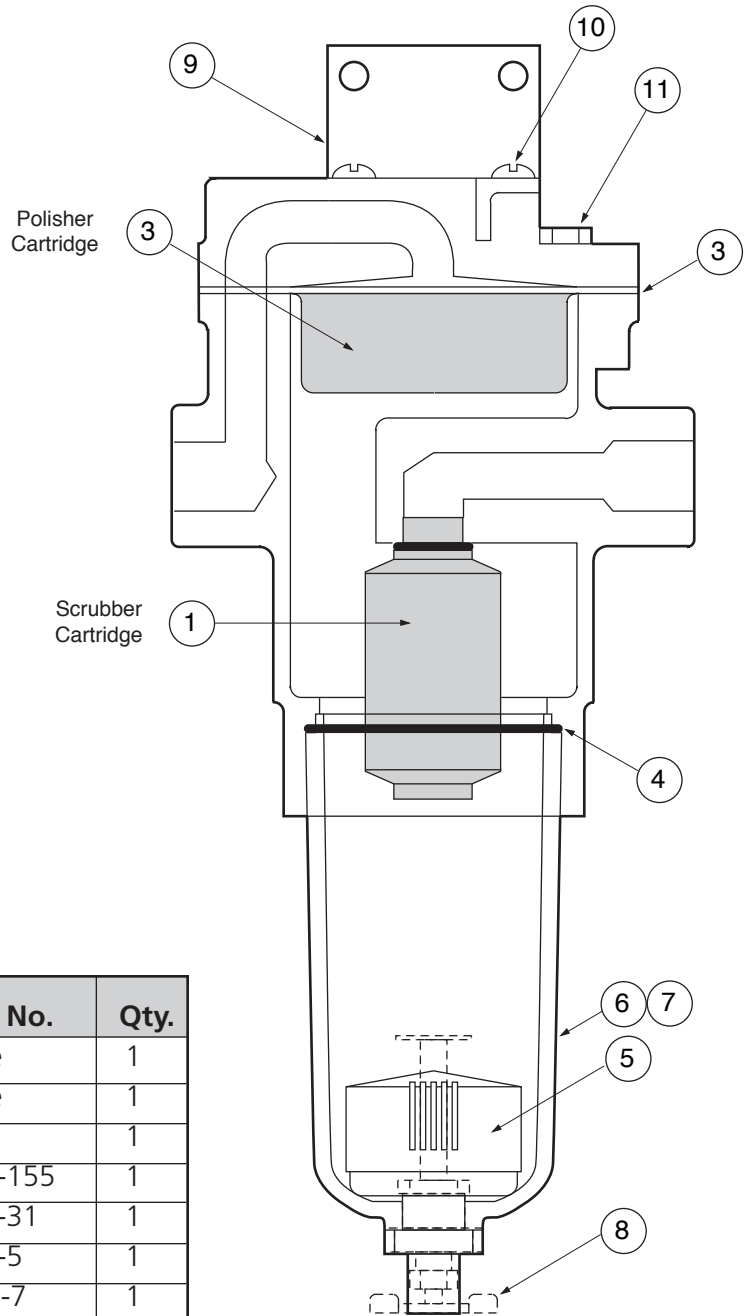

| Item | Description | Part No. | Qty. |
|--------|--------------------------------|----------|------|
| 1 | Scrubber Cartridge (1st Stage) | above | 1 |
| 2 | Polisher (2nd Stage) | above | 1 |
| 3 | Gasket | 9329 | 1 |
| 4 | O-Ring | 2200-155 | 1 |
| 5 | Automatic Drain | 2465-31 | 1 |
| 6 | Sump w/Auto. Drain (note 1) | 4522-5 | 1 |
| 7 | Sump w/Manual Drain (note 1) | 3277-7 | 1 |
| 8 | Manual Drain Petcock | 6120-4 | 1 |
| 9 | Mounting Bracket | 7624-3 | 1 |
| 10 | Bracket Screw | 1544S-3 | 2 |
| 11 | Housing Bolt | 8279-19 | 4 |
| Notes: | | | |

1. To replace sump only, order p/n 3277-7.
2. Shatterguards are available for the polycarbonate filter sump. Details upon request.
3. Item 1 includes o-ring, p/n 6495-10.

Cartridge Replacement

Under normal operating conditions, the only servicing which need be done to a King filter is to change the cartridges. The number of times that this must be done will vary with each installation. Generally, the cartridges are changed when the pressure drop across the filter becomes objectionable.

To change the cartridges the following procedure should be followed:

1. Turn off the air supply and drain the filter. This will vent the filter of all compressed air.
2. Remove the sump.
3. By using a King Filter utility wrench (p/n 2585) or inserting the points of long nose pliers into the two slots in the bottom of the scrubber cartridge it can be unscrewed. Install a new scrubber cartridge and replace the sump.
4. Remove the four housing bolts from the top of the filter and lift off the cover plate. Remove the gasket and lift out the old polisher cartridge.
5. Drop in a new polisher cartridge followed by a new gasket and the cover plate. Tighten the four screws alternating from one to another until all are tightened.
6. Turn on the air supply and the filter will start functioning immediately.

To clean polycarbonate bowls use mild soap and water only. Do not use cleaning agents such as acetone, benzene, gasoline, toluene, carbon tetrachloride, etc., which are damaging to this plastic

Caution! It is important to the proper operation of the filter that the sump be drained daily (or be equipped with auto-drain). Failure to do this may cause permanent damage to equipment downstream of the filter.

