



## Service Parts & Dimensions

6000-750.00

Effective: February, 1998 (replaces April, 1993)

# 750/1000 SCFM Triple-Guard Filters

### Models Numbers/Rated Flow –

#### 2440-3 –

750 SCFM @ 100 psig  
21237 L/min @ 7 kg/cm<sup>2</sup>  
1275 m<sup>3</sup>/hr @ 7 bar

#### 2441-3 –

1000 SCFM @ 100 psig  
28316 L/min @ 7 kg/cm<sup>2</sup>  
1700 m<sup>3</sup>/hr @ 7 bar

### Connections –

3" flange  
(150 Class ANSI)

### Max. Pressure –

250 psi max.

### Physical Data –

Housing - Carbon Steel  
Weight – 425 lbs.

### Discontinued Models –

2440-1 (750 SCFM)  
2440-8 (750 SCFM)  
2441-1 (1000 SCFM)  
2441-8 (1000 SCFM)

Replacement items listed  
on reverse side apply to  
above models.

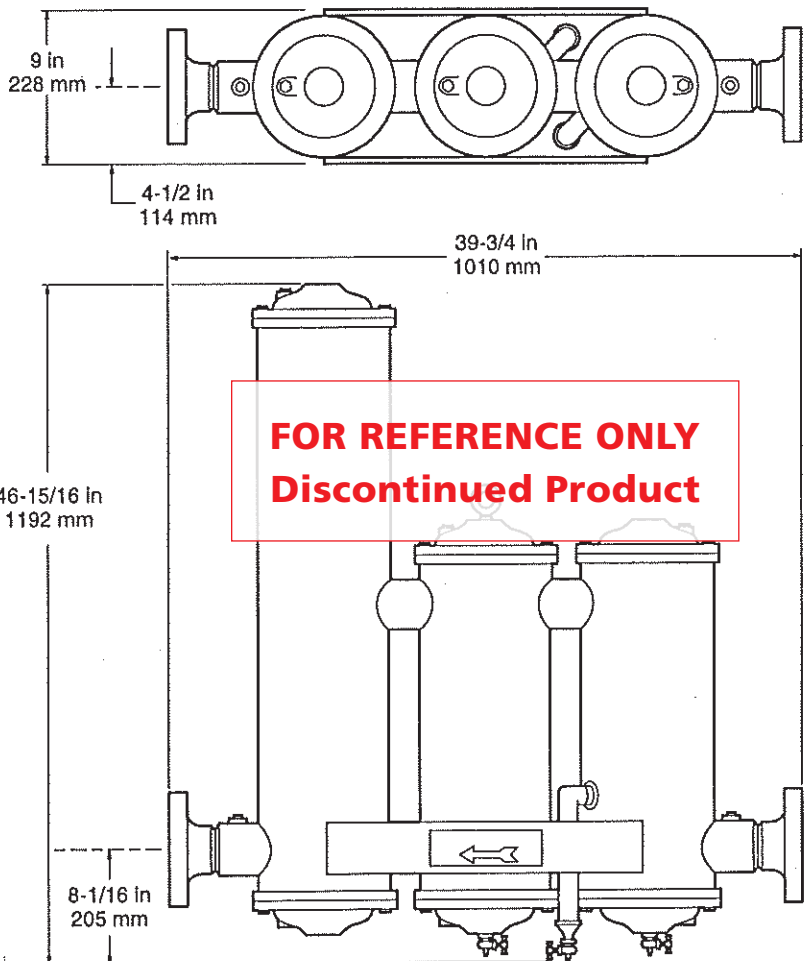

P. O. Box 1228, Ann Arbor, Michigan 48106-1228 U.S.A.  
3201 South State Street, Ann Arbor, Michigan 48108-1625 U.S.A.

Phone: (734) 662-5691 • FAX: (734) 662-6652 • www.king-gage.com

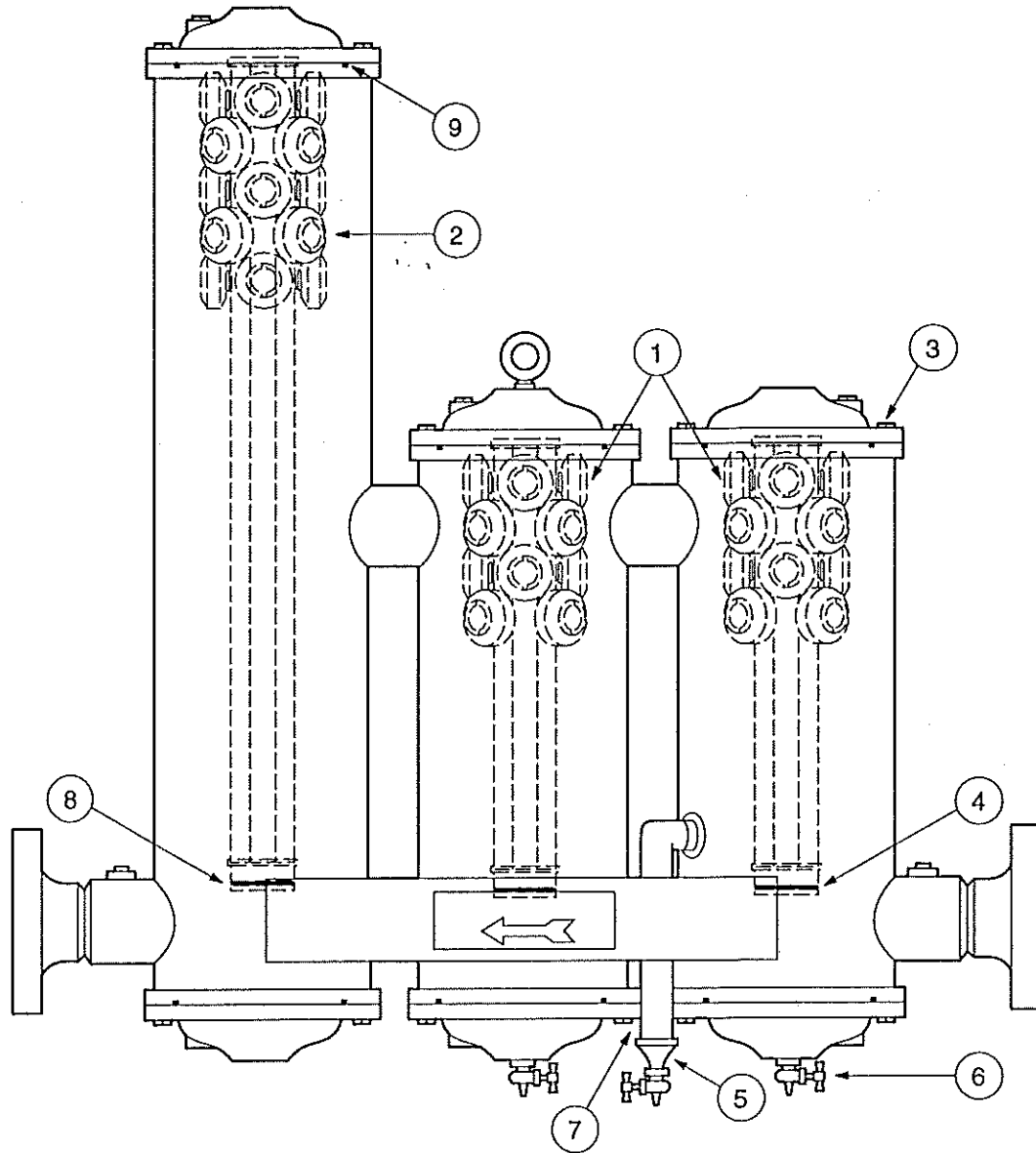

Item	Description	Part No.	Qty.
1	Pair of Scrubber Cartridge Assy's.	See Chart	1
2	Polisher Cartridge Assy.	See Chart	1
3	3/8"-16 Hex Nut	8763-9	48
4	O-Ring (note 1)	9316-6	2
5	Reducing Coupling	6178-13CP	2
6	Drain Valve	9509-12	4
7	Nipple	6173-44	2
8	O-Ring (note 2)	9316-4	1
9	O-Ring (note 3)	9316-39	6

**(2nd Stage) Scrubber Cartridges**

Cartridge Type	750 SCFM	1000 SCFM
100	2422-32-4	2422-48-4
300	2422-32-1	2422-48-1

**(3rd Stage) Polisher Cartridges**

Cartridge Type	750 SCFM	1000 SCFM
100	2424-40-4	2424-56-4
300	2424-40-1	2424-56-1

**Notes:**

1. Included as part of item 1 replacement assembly.
2. Included as part of item 2 replacement assembly.
3. Used with upper and lower cover plates.