



# Service Parts & Dimensions

6000 - 80.00

Effective : February,1998 (replaces April, 1993)

## 80 SCFM Air-Guard™ Coalescing Filters

### Models:

- 2479-1 Filter w/Manual Drain
- 2479-1T Filter w/Automatic Drain

### Rated Flow:

- 80 SCFM @ 100 psig
- 2265 l/min @ 7 Kg/cm<sup>2</sup>
- 136 m<sup>3</sup>/hr @ 7 bar

### Max. Pressure:

150 psi

### Connections:

1 in NPT

### Cartridges: Two (2) Element Design -

- 1st Stage Scrubber (coalescing)
- 2nd Stage Polisher (adsorptive)

### Physical Data:

- Housing - Aluminum
- Weight - 25 lbs.

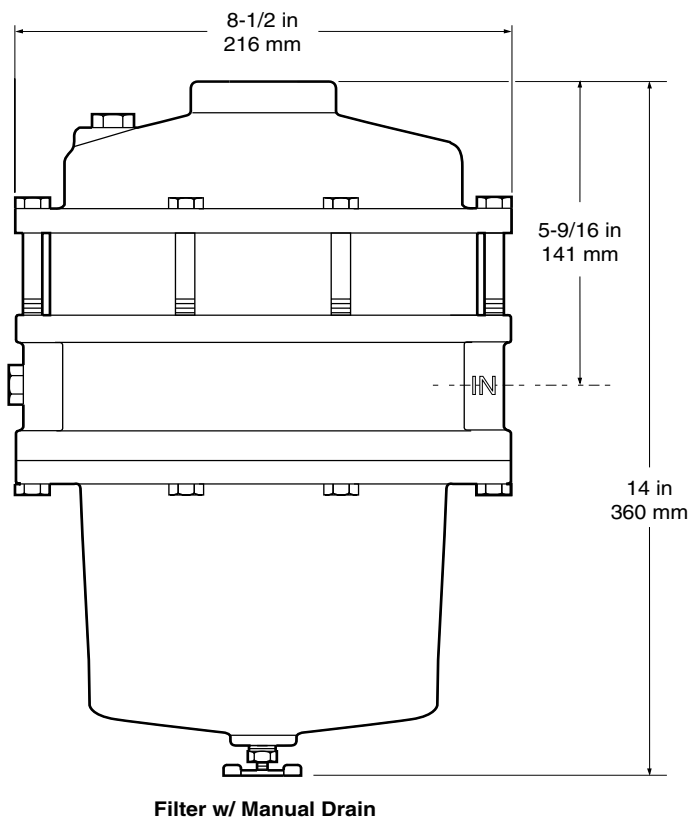
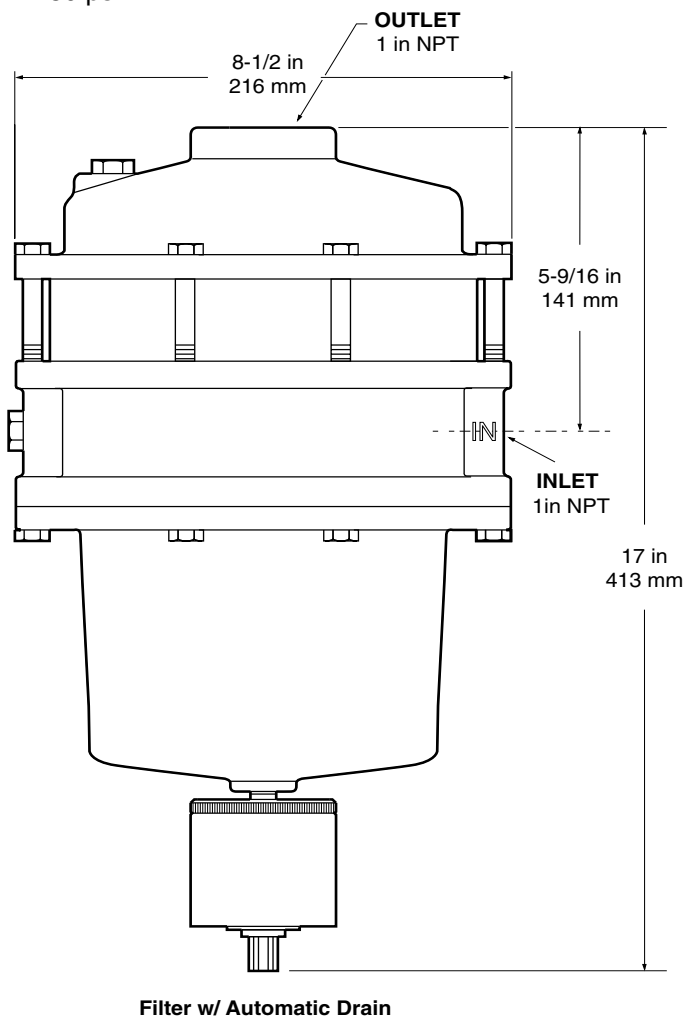

### Inside:

- Installation Instructions ..... page 2
- Service Parts ..... page 3
- Cartridge Replacement ..... page 4

# Installation Instructions

## End-Use Filters

Filtering the entire compressed air system at one central location does not generally provide sufficient cleaning for all end-use applications. Moreover, most compressed air piping contains some amount of rust, scale and condensed liquids. Water vapor that may be present in warm air will tend to condense into liquid when the air cools.

A compressed air filter installed just upstream of the end-use is generally the most efficient means of ensuring clean, dry air. These end-use filters can provide clean air to meet individual process requirements. A coalescing filter should be specified due to its long service life where liquid contaminants may be encountered.

*Do not undersize a compressed air filter.* Exceeding the listed flow rate of the filter will have a proportionate

decrease in the service life of the cartridge elements. Frequent cartridge replacement necessitated by undersizing an application significantly increases maintenance costs. Maximum efficiency is generally obtained between 15%-100% of the maximum rating.

## Vapor and Condensation

Many types of pneumatic equipment and processes use compressed air that must be clean, dry and oil-free. This requires the removal of liquids, aerosols, dust and solid particulates from the airstream. Generally, only condensed liquids need to be removed. Visible fog or mist is actually composed of condensed liquid droplets. These are easily removed by using a coalescing compressed air filter at the end-use point.

Vapor is liquid in evaporated form. In this gaseous state, the liquid vapor will be invisible. Oil and water vapor are commonly present in compressed air systems. If either type of vapor must be removed, a compressed air dryer must be used. Desiccant dryers, for instance, use media that attracts the vapor molecules through a process called "adsorption".

## Application Note

Manufacturer's warranties are void in the event of misapplication or negligence and manufacturer assumes no responsibility for loss under such circumstances.

## Installation Instructions

1. Locate filter in coolest location in air system.
2. Install drip leg upstream of filter.
3. Locate filter as near end use as possible.
4. Always make inlet connection to port marked "Inlet" on the filter.
5. Auto Drain requires minimum 20 psi (1.4 kg/cm<sup>2</sup>) inlet pressure for proper operation.
6. Pressure gauges installed on both sides of the filter are useful to indicate when filter is being used in its proper flow range and also indicate when cartridges need replacing.
7. Pressure rating 150 psig. Maximum temperature is 200° F./93° C.
8. It is important to the proper operation of the filter that the sump be drained daily (or be equipped with auto-drain). Failure to do this may cause permanent damage to equipment down-stream of the filter.

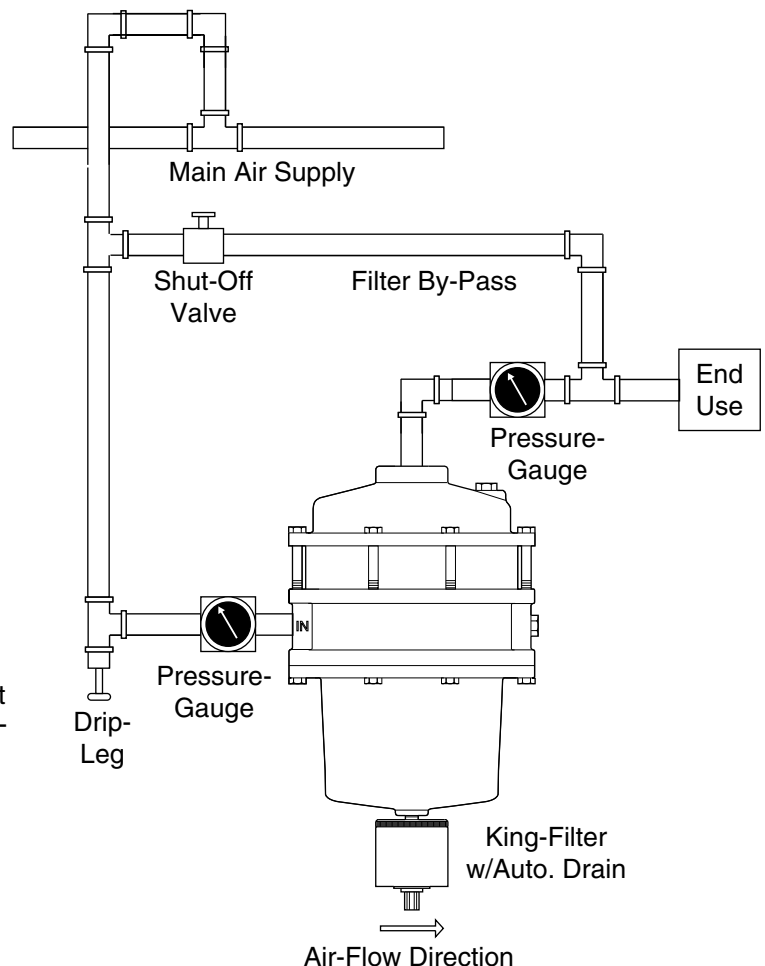

## Service Parts

### Replacement Filter Cartridges:

#### (Standard)

0.1 Micron Replacement Set 22-41-6-5  
Includes: Type 750 Scrubber (qty. 4) and  
Type 800 Polisher (qty. 1)

Type 750 Scrubber only - Order no. 2430-4-6  
Type 800 Polisher only - Order no. 9326-241

#### (Optional)

2.0 Micron Replacement Set 22-41-1-1  
Includes: Type 300 Scrubber (qty. 4) and  
Type 300 Polisher (qty. 1)

Type 300 Scrubber only - Order no. 2430-4-1  
Type 300 Polisher only - Order no. 9326-201

Note: Other cartridge grades are available.  
Details upon request.

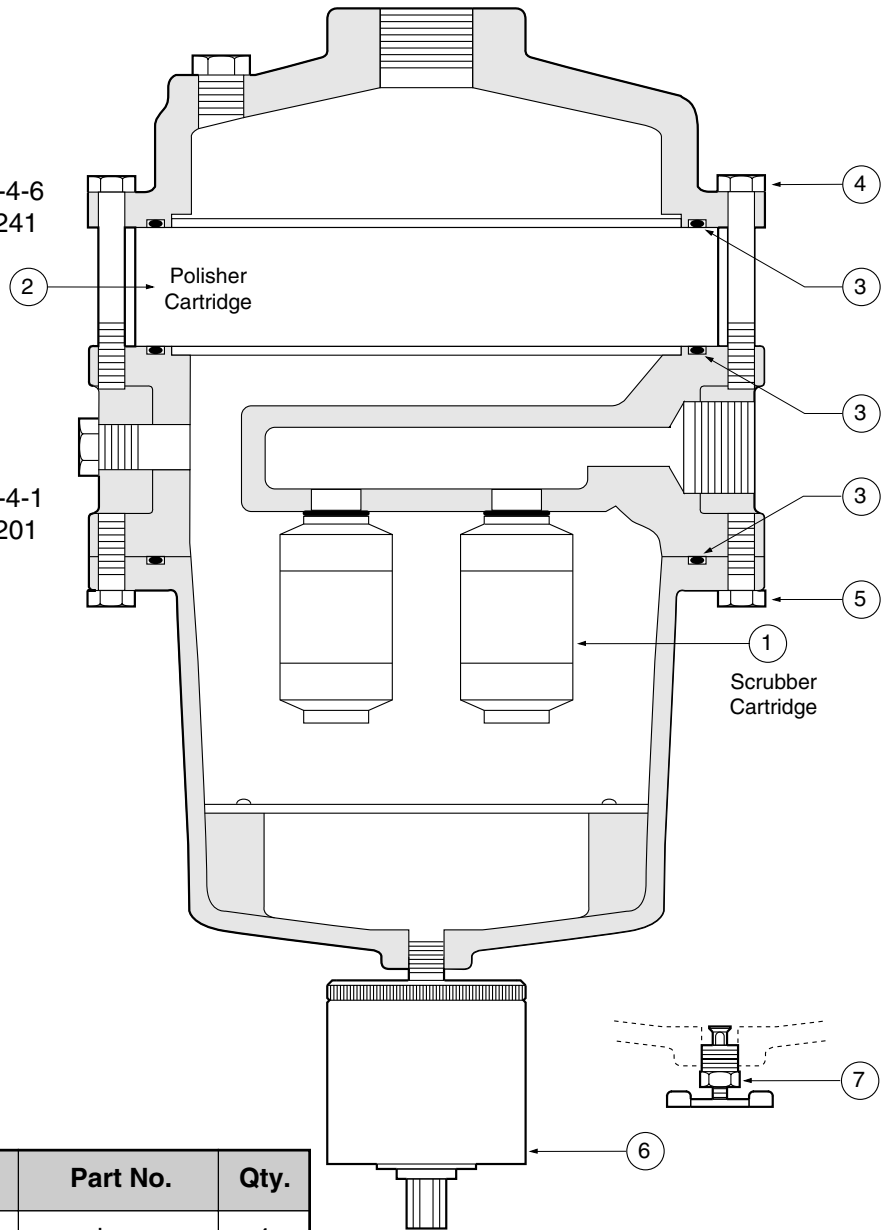

Item	Description	Part No.	Qty.
1	Scrubber Cartridge (1st Stage)	above	4
2	Polisher Cartridge (2nd Stage)	above	1
3	O-Ring	9316-39	3
4	Cap Screw	10143-11	8
5	Cap Screw	10143-7	8
6	Automatic Drain	2465-36	1
7	Manual Drain Petcock	6120-4	1

## Cartridge Replacement

Under normal operating conditions, the only servicing which need be done to a King Filter is to change the cartridges. The number of times that this must be done will vary with each installation. Generally, the cartridges are changed when the pressure drop across the filter becomes objectionable.

To change the cartridges, the following procedure must be followed:

1. Turn off the air supply and drain the filter; this will vent the filter of all compressed air.
2. Loosen the screws holding the sump in place and carefully lower the sump.
3. On filters so equipped, remove the scrubber cartridge from the cartridge extension pieces. Place a wrench on the extensions so that they are not removed. By using a King Filter utility wrench (p/n 2585) or inserting the points of long nose pliers into the two slots in the bottom of the scrubber cartridge, it can be unscrewed.
4. Remove the remaining cartridges and install new units in their place. Replace the sump being sure the sump o-ring is in place.
5. Loosen the screws holding the cover plate in place and carefully remove the cover plate and polisher cartridge.
6. The o-ring in the cover plate and filter body should be lubricated lightly with a vaseline type lubricant.
7. When installing the new polisher, be sure the surface with the index pin and hex head nut is on the bottom. This positioning insures correct air flow direction through the cartridge. Reinstall cover plate.
8. Close the drain valve and slowly turn on the air supply. The filter will start functioning immediately.

**Caution!** it is important to the proper operation of the filter that the sump be drained daily (or be equipped with auto-drain). Failure to do this may cause permanent damage to equipment downstream of the filter.

