



# Condensed Catalog



**Compressed Air  
Coalescing Filters,  
Filter-Dryers, Dryers,  
Aerosol Filters and  
Pressure Regulators**



**Terms and Conditions**

**Terms and Conditions of Sale** — All prices are quoted in U.S.A. dollars. Pricing and availability are subject to change without notice. Shipment terms are F.O.B. Factory, Ann Arbor, Michigan.

**Payment Methods** — Include credit card, prepay, C.O.D., wire transfer or open account. New customers may apply for open account by completing a Credit Application and Agreement form. Open account standard terms are Net 30 days. A 1-1/2% (18% annually) service charge will be added to all past due amounts.

**Taxes** — Prices do not include any federal, state or local, sales, use, occupation and/or excise taxes or duties. Customers will be liable for any such taxes unless statement or exemption is provided.

**Packaging** — Prices include standard packaging in such a manner as to prevent damage through normal handling by the shipping method used. Special packaging, if required or requested, will be quoted as a separate item.

**Re-stocking Policy** — Under certain conditions the Factory will accept returned materials for credit - less any applicable re-stocking charge. The minimum handling charge is 15% of invoice price or \$50.00 - which ever is greater. The product must be returned in the original packaging within 3 months of shipment. Contact the Factory for details and return authorization number.

**Warranty** — All King Engineering products are guaranteed to be free from defects in material and workmanship for one year from date of purchase. Any product or part found to be defective under normal use within one year from the date of purchase will be repaired or replaced at no charge if returned to the company at Ann Arbor, Michigan within ten days of discovery of the defect. No other warranties, whether expressed, implied or statutory, including the warranties of fitness for a particular purpose or merchantability, are given by this agreement.

The exclusive remedy for nonconformity of these goods shall be repair and replacement of the nonconforming goods or parts.

Seller shall not be liable for consequential damages resulting from breach of this agreement. The term “consequential damages” shall include but not be limited to damage to all machines, equipment and goods other than the goods sold hereby, interruption of production, loss of profits, delays of any kind, administrative expense and overhead.

**KING Filter & Cartridge Set key**

**9460 - 3T - 6 - 5**

Base Number

**Polisher Type**

|   |     |
|---|-----|
| 5 | 800 |
| 4 | 100 |
| 2 | 400 |
| 1 | 300 |

**Scrubber Type**

|   |     |
|---|-----|
| 6 | 750 |
| 4 | 100 |
| 2 | 400 |
| 1 | 300 |

Standard cartridge set is highlighted.

© 2006 King Engineering Corporation. All rights reserved.

® KING-GAGE and the KE emblem are registered trademarks of King Engineering Corporation, Ann Arbor MI, U.S.A.

™ Air-Guard, Metl-Guard, Triple Guard, Ultra-C and Visi-Guard are trademarks denoting KING Filters manufactured by King Engineering Corporation, Ann Arbor, MI, U.S.A.

The information contained in this price list was accurate at the time of release. Pricing and specifications are subject to change without notice.

**Ultra-C™  
Coalescing  
20  
SCFM Filters**

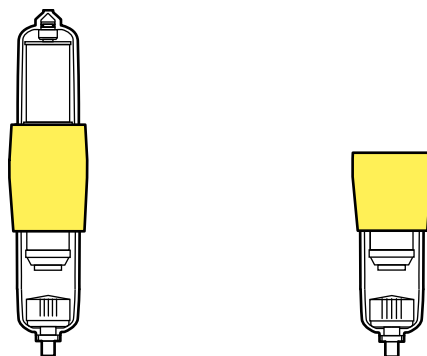

|                      |                     |              |                    |              |
|----------------------|---------------------|--------------|--------------------|--------------|
| <b>Rated Flow</b>    | 20 SCFM             |              | 20 SCFM            |              |
| <b>Connections</b>   | 1/2" NPT            |              | 1/2" NPT           |              |
| <b>Max. Pressure</b> | 150 psi             |              | 150 psi            |              |
| <b>Micron Rating</b> | 0.1 Micron (99.98%) |              | 0.5 Micron (99.9%) |              |
| <b>Housing</b>       | Aluminum            |              | Aluminum           |              |
| <b>Sump</b>          | Polycarbonate       |              | Polycarbonate      |              |
| <b>Drain</b>         | Manual              | Auto.        | Manual             | Auto.        |
| <b>Model</b>         | <b>U-202</b>        | <b>U-203</b> | <b>U-200</b>       | <b>U-201</b> |

■ Filters include Ultra-C cartridge elements. (Ultra-C elements are not interchangeable with other KING filter cartridge elements.)

**Air-Guard™  
Coalescing  
20 SCFM  
Filters**



|                |                 |
|----------------|-----------------|
| 20 SCFM        |                 |
| 1/2" NPT       |                 |
| 150 psi        |                 |
| Bronze         |                 |
| Bronze         |                 |
| Manual         | Auto.           |
| <b>9313-24</b> | <b>9313-24T</b> |

**Effective Flow Rates for KING  
Filters Based on Inlet Pressure**

|                              | SCFM     |           |           |           |           |
|------------------------------|----------|-----------|-----------|-----------|-----------|
| @ 150 psig                   | 3        | 18        | 30        | 90        | 120       |
| <b>Rated Flow @ 150 psig</b> | <b>2</b> | <b>12</b> | <b>20</b> | <b>60</b> | <b>80</b> |
| @ 70 psig                    | 1.6      | 9.6       | 16        | 48        | 64        |
| @ 50 psig                    | 1.2      | 7.2       | 12        | 36        | 48        |
| @ 25 psig                    | 0.6      | 3.6       | 6         | 18        | 24        |

■ Filters models are listed by rated flow at 100 psig delivered into free air.

■ Filters listed include type 750/800 cartridge set.

**Air-Guard™  
Coalescing  
60, 80 & 100  
SCFM Filters**

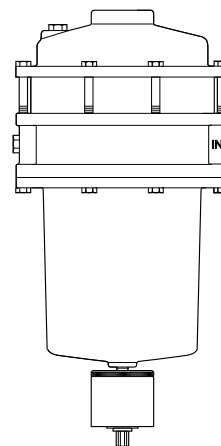
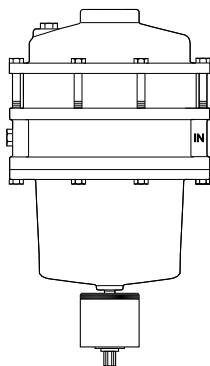
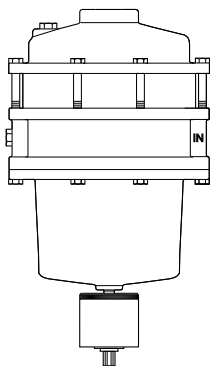

|                      |               |                |               |                |               |                |
|----------------------|---------------|----------------|---------------|----------------|---------------|----------------|
| <b>Rated Flow</b>    | 60 SCFM       |                | 80 SCFM       |                | 100 SCFM      |                |
| <b>Connections</b>   | 1" NPT        |                | 1" NPT        |                | 1" NPT        |                |
| <b>Max. Pressure</b> | 150 psi       |                | 150 psi       |                | 150 psi       |                |
| <b>Housing</b>       | Aluminum      |                | Aluminum      |                | Aluminum      |                |
| <b>Sump</b>          | Aluminum      |                | Aluminum      |                | Aluminum      |                |
| <b>Drain</b>         | Manual        | Auto.          | Manual        | Auto.          | Manual        | Auto.          |
| <b>Model</b>         | <b>9460-3</b> | <b>9460-3T</b> | <b>2479-1</b> | <b>2479-1T</b> | <b>2260-1</b> | <b>2260-1T</b> |

■ Filters listed include type 750/800 cartridge set.

**Visi-Guard™ &  
Metl-Guard™  
Dryers**

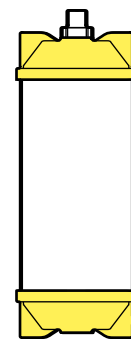
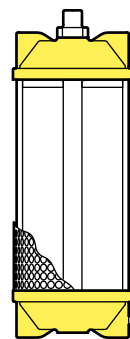
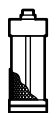

|                      |                                     |                                     |                                     |                                     |
|----------------------|-------------------------------------|-------------------------------------|-------------------------------------|-------------------------------------|
| <b>Rated Flow</b>    | 2 SCFM                              | 2 SCFM                              | 12 SCFM                             | 12 SCFM                             |
| <b>Connections</b>   | 1/4" NPT                            | 1/4" NPT                            | 1/2" NPT                            | 1/2" NPT                            |
| <b>Dryer Type</b>    | Visi-Guard<br>Single Stage<br>Dryer | Metl-Guard<br>Single Stage<br>Dryer | Visi-Guard<br>Single Stage<br>Dryer | Metl-Guard<br>Single Stage<br>Dryer |
| <b>Max. Pressure</b> | 150 psi                             | 150 psi                             | 150 psi                             | 150 psi                             |
| <b>Housing</b>       | Alum/Acrylic                        | Aluminum                            | Alum/Acrylic                        | Aluminum                            |
| <b>Model</b>         | <b>1734-6-*</b>                     | <b>1734-2-*</b>                     | <b>1716-10-*</b>                    | <b>1716-6-*</b>                     |

■ Prices include desiccant charge. \*Please specify desiccant type when ordering dryer.

**Visi-Guard™ & Metl-Guard™ Filter/Dryers**

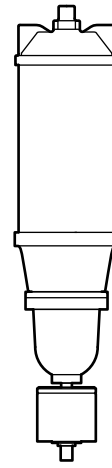
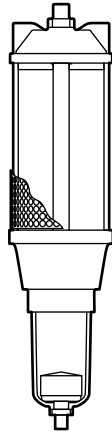

|                      |                                    |                 |                                    |                 |
|----------------------|------------------------------------|-----------------|------------------------------------|-----------------|
| <b>Rated Flow</b>    | 12 SCFM                            |                 | 12 SCFM                            |                 |
| <b>Connections</b>   | 1/2" NPT                           |                 | 1/2" NPT                           |                 |
| <b>Dryer Type</b>    | Visi-Guard Dual Stage Filter-Dryer |                 | Metl-Guard Dual Stage Filter-Dryer |                 |
| <b>Max. Pressure</b> | 150 psi                            |                 | 150 psi                            |                 |
| <b>Housing</b>       | Alum/Acrylic                       |                 | Aluminum                           |                 |
| <b>Sump</b>          | Polycarbonate                      |                 | Aluminum                           |                 |
| <b>Drain</b>         | Manual                             | Auto.           | Manual                             | Auto.           |
| <b>Model</b>         | <b>4532-23</b>                     | <b>4532-23T</b> | <b>1784-15</b>                     | <b>1784-15T</b> |

■ Filters listed include type 750 scrubber cartridge and desiccant charge. Please specify desiccant type when ordering filter-dryer.

**Dryer & Desiccant Key**

**1716 - 10 - 1**

Base Number

**Desiccant Type**

- 1 ..... SG-1
- 4 ..... AC-1
- 5 ..... MS-1
- 6 ..... MS-2
- 8 ..... SG-2

**Filter-Dryer & Desiccant key**

**4532 - 23T - 6 - 1**

Base Number

**Scrubber Type**

- 6 ..... 750
- 4 ..... 100
- 2 ..... 400
- 1 ..... 300

**Desiccant Type**

- 1 ..... SG-1
- 4 ..... AC-1
- 5 ..... MS-1
- 6 ..... MS-2
- 8 ..... SG-2

Standard cartridge set is highlighted.

**SG-1 Indicating Silica Gel** – Changes from bright blue to pink as water vapor is adsorbed. Can lower dew point to -50°F (-45°C). Rated for temperatures up to 100°F (38°C).

**MS-1 Silicate** – Higher temperature desiccant for water vapor removal. Lowers dew point to -100°F (-73°C). Rated for temperatures up to 200°F (93°C).

**MS-2 Silicate** – Molecular seive desiccant for removing oil vapor. Can reduce oil content to under 0.5 ppm (w/w rating). Rated for temperatures to 200°F (93°C).

**AC-1 Activated Charcoal** – Removes oil vapor and is especially useful in removing oily taste/smell from compressed air. Rated for temperatures to 120°F (49°C).

**Desiccant Replacement Charges** – For Water & Oil Vapor Removal

| Type                       | SG-1        | MS-1          | MS-2          | AC-1          |
|----------------------------|-------------|---------------|---------------|---------------|
| Material                   | silica gel  | silicate      | silicate      | charcoal      |
| Removal                    | water vapor | water vapor   | oil vapor     | oil vapor     |
| <b>2 SCFM Recharge</b>     | <b>1735</b> | <b>1735-5</b> | <b>1735-6</b> | <b>1735-4</b> |
| <b>10/12 SCFM Recharge</b> | <b>1730</b> | <b>1730-5</b> | <b>1730-6</b> | <b>1730-4</b> |

■ Silica Gel changes color from bright blue to pink as water vapor is adsorbed. Silicate refers to a molecular sieve material composed of sodium alumino silicate and does not change color. Charcoal refers to activated charcoal for oil vapor and/or odor removal.

**Triple Guard™ Discontinued**  
**350/500/750/1000 scfm**  
**Models No Longer Available**

**Replacement Cartridge Sets Only**  
**(See Page 10)**

**100 SCFM Aerosol Filter**

|               |                 |
|---------------|-----------------|
| Connections   | 1" NPT          |
| Max. Pressure | 150 psig        |
| Housing       | Aluminum        |
| <b>Model</b>  | <b>2160-3-5</b> |

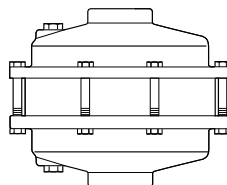

**2 SCFM Aerosol Strainers** – One Piece Disposable Filters

| Connections   | 1/4" NPT            | 1/4" NPT            | 1/4" NPT            |
|---------------|---------------------|---------------------|---------------------|
| Inlet         | male                | female              | female              |
| Outlet        | female              | male                | female              |
| Max. Pressure | 125 psig            | 125 psig            | 125 psig            |
| Housing       | Steel               | Steel               | Steel               |
| <b>Model</b>  | <b>2201-14-12-1</b> | <b>2201-32-12-1</b> | <b>2201-34-12-1</b> |

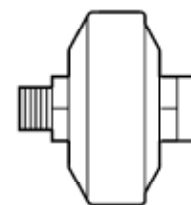

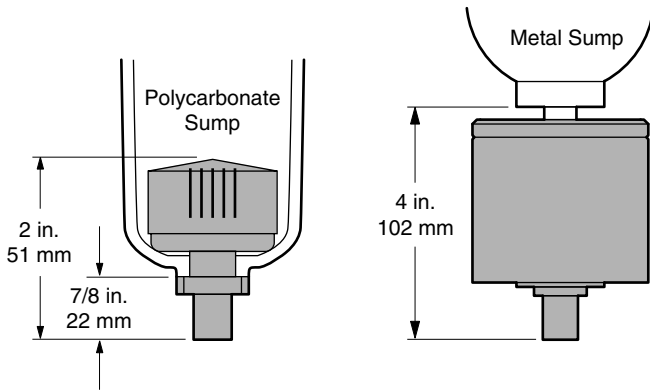

**Auto-Drains (12 to 200 SCFM Service)**

| Use for            | Poly. Sump     | Metal Sump     |
|--------------------|----------------|----------------|
| <b>Part Number</b> | <b>2465-31</b> | <b>2465-36</b> |

**Metal Shatterguard**

| Use For            | Part No.  |
|--------------------|-----------|
| Polycarbonate Sump | 3255-30-1 |

- Not for 12 SCFM, Ultra-C U-122/U-123 filters. Can also be used for 20 SCFM Color-Change upper bowl. Also replaces U3052.

**Mounting Brackets**

| Applicable Filters    | Part No.  |
|-----------------------|-----------|
| 12 SCFM Ultra-C       | U6524-163 |
| 20 SCFM Ultra-C       | U6524-151 |
| 60/80/100 SCFM Filter | 1707-3    |

- Bracket used to secure filter housing to wall or other structural member.

**Pressure Drop Kits**

| Inlet Pressure | NPT     | Part No.  |
|----------------|---------|-----------|
| 150 psi        | 1/2 in. | 1760-3-53 |
| 150 psi        | 1/4 in. | 1760-7-53 |
| 300 psi        | 1/4 in. | 1760-3-55 |

- Pressure drop kits include a pair of matched pressure gauges. These are used to signal element replacement as pressure drop increases.

**Replacement Sumps**

| Description                         | Part No. |
|-------------------------------------|----------|
| Ultra-C 12 SCFM Sump w/Manual Drain | U4001    |
| Ultra-C 12 SCFM Sump w/Auto-Drain   | 4522-6   |
| Polycarbonate Sump w/Manual Drain   | 3277-7   |
| Polycarbonate Sump w/Auto-Drain     | 4522-5   |
| Upper Bowl (12 SCFM Color-Change)   | U4002    |
| Upper Bowl (20 SCFM Color-Change)   | 3277-8   |

- U4003 is replaced by 3277-7. U4004 is replaced by 3277-8.

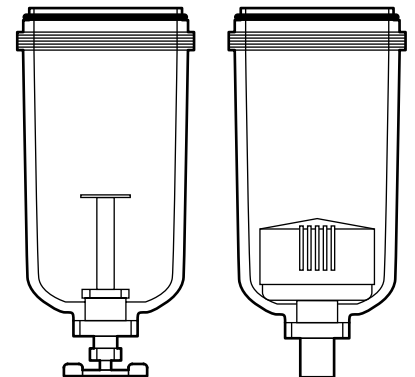

Polycarbonate Sump with Manual Drain

Polycarbonate Sump with Auto-Drain

## Air-Guard Filter Replacement Cartridges

### Replacement Cartridge Sets for 2-Stage Filters

| SCFM | Cartridge Type            | Micron Rating | Part Number |
|------|---------------------------|---------------|-------------|
| 20   | 300 Scrubber/300 Polisher | 2.0           | A22-11-1-1  |
| 20   | 750 Scrubber/800 Polisher | 0.1           | A22-11-6-5  |
| 60   | 300 Scrubber/300 Polisher | 2.0           | 22-31-1-1   |
| 60   | 750 Scrubber/800 Polisher | 0.1           | 22-31-6-5   |
| 80   | 300 Scrubber/300 Polisher | 2.0           | 22-41-1-1   |
| 80   | 750 Scrubber/800 Polisher | 0.1           | 22-41-6-5   |
| 100  | 300 Scrubber/300 Polisher | 2.0           | A22-51-1-1  |
| 100  | 750 Scrubber/800 Polisher | 0.1           | A22-51-6-5  |

■ Includes 1st stage (scrubber) cartridge, 2nd stage (polisher) cartridge and gasket seal. For color-change filters, see Ultra-C Cartridges listing on page 10.

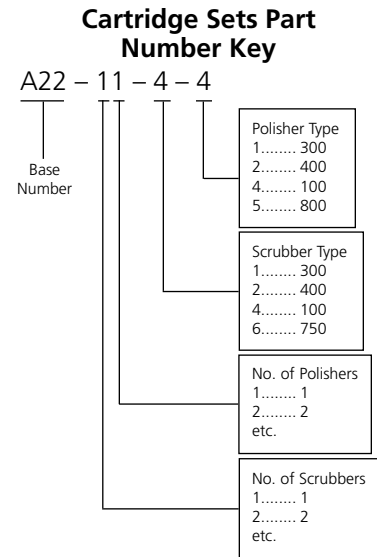

### Replacement Scrubber (1st Stage) Cartridges

| Cartridge Type | Part No. | Quantity Based on Filter Flow Rating |               |               |               |
|----------------|----------|--------------------------------------|---------------|---------------|---------------|
|                |          | 20 SCFM                              | 60 SCFM       | 80 SCFM       | 100 SCFM      |
| 100            | 9318-31  | 20 SCFM                              | 60 SCFM       | 80 SCFM       | 100 SCFM      |
| 300            | 9318     | Filters                              | Filters       | Filters       | Filters       |
| 400            | 9318-11  | (1) Scrubber                         | (3) Scrubbers | (4) Scrubbers | (5) Scrubbers |
| 750            | 9318-80  | required                             | required      | required      | required      |

■ Filters with rated flows above 20 SCFM use multiple Scrubber cartridge elements. Order quantity indicated based on filter flow rating. Not for use with Ultra-C Color-Change or single stage models (see page 10).

### Replacement Polisher (2nd Stage) Cartridges

| Cartridge Type | 20 SCFM | 60/80/100 SCFM | 100/200 SCFM |
|----------------|---------|----------------|--------------|
| 100            | A31-1-4 | 9326-231       | 9326-131     |
| 300            | A31-1-1 | 9326-201       | 9326-101     |
| 400            | A31-1-2 | 9326-211       | 9326-111     |
| 800            | A31-1-5 | 9326-241*      | 9326-141     |



Type 750 Scrubber

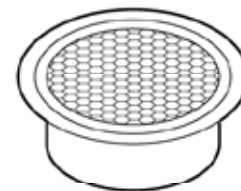

Type 800 Polisher

■ Polisher element part numbers listed include replacement sealing gasket for filter housing. See page 10 for Ultra-C Color-Change Type 750 Polisher.

■ **Note:** HP Service 100/200 SCFM polisher used for discontinued 300 psi service filters having ductile iron housings.

\* Also used as replacement element for 2160-3-5 Aerosol Filter.

**Ultra-C™ Replacement Cartridges**

**Ultra-C™ Replacement Scrubber**

| Cartridge Type | 12 SCFM | 20 SCFM |
|----------------|---------|---------|
| 750            | U3000   | U3002   |

**Ultra-C™ Color-Change Polisher**

| Cartridge Type | 12 SCFM | 20 SCFM |
|----------------|---------|---------|
| 750            | U3001   | U3003   |

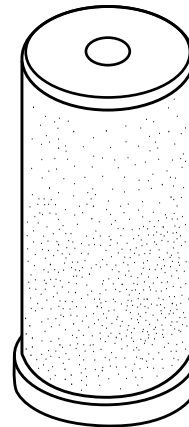

Type 750  
Color-Change  
Polisher

■ **Note:** For Air-Guard Filter 4580-19 (obsolete) re-order color change polisher part number 4584 (\$62.00).

**Triple Guard™ Mainline Filter Replacement Cartridges**

**(2nd Stage) Scrubber Cartridge Assembly**

| Cartridge Type | 350 SCFM  | 500 SCFM  | 750 SCFM   | 1000 SCFM  |
|----------------|-----------|-----------|------------|------------|
| 100            | 2422-16-4 | 2422-24-4 | 2422-32-4* | 2422-48-4* |
| 300            | 2422-16-1 | 2422-24-1 | 2422-32-1* | 2422-48-1* |

\* Part numbers listed for 750 & 1000 SCFM scrubber includes two (2) cartridge assemblies. 2422-32-x consists of a pair of 16-element cartridge assemblies. 2422-48-x consists of a pair of 24-element cartridge assemblies.

**(3rd Stage) Polisher Cartridge Assembly**

| Cartridge Type | 350 SCFM  | 500 SCFM  | 750 SCFM  | 1000 SCFM |
|----------------|-----------|-----------|-----------|-----------|
| 100            | 2424-20-4 | 2424-28-4 | 2424-40-4 | 2424-56-4 |
| 300            | 2424-20-1 | 2424-28-1 | 2424-40-1 | 2424-56-1 |

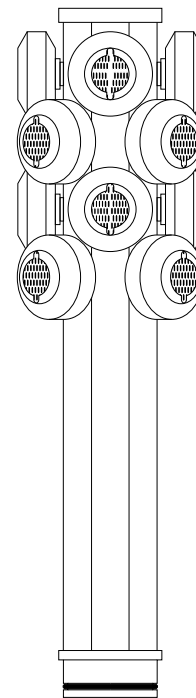

Triple-Guard  
Scrubber Cartridge  
Assembly

**Obsolete King Filters & Accessories**

|                    |  |
|--------------------|--|
| 1716-26 .....      | Metl-Guard Dryer 10 scfm; w/ moisture bullseye                     |
| 1716-30 .....      | Visi-Guard Dryer 10 scfm; w/ moisture bullseye                     |
| 1730-8 SG-2 .....  | Silica Gel (non-indicating); 10/12 scfm recharge pack              |
| 1735-8 SG-2 .....  | Silica Gel (non-indicating); 1/2 scfm recharge pack                |
| 1743-42 .....      | Bullseye Moisture Indicator; 3/8" NPT; in-line mount               |
| 1743-43 .....      | Bullseye Moisture Indicator; 1/4" NPT; flush mount                 |
| 1743-44 .....      | Bullseye Moisture Indicator; 3/8" NPT; flush mount                 |
| 1784-231 .....     | Metl-Guard Filter/Dryer 10 scfm; moisture bullseye; manual drain   |
| 1784-231T .....    | Metl-Guard Filter/Dryer 10 scfm; moisture bullseye; auto drain     |
| 2020-2 .....       | Metl-Guard Filter/Dryer 2 scfm; manual drain                       |
| 2020-3 .....       | Visi-Guard Filter/Dryer 2 scfm; manual drain                       |
| 2100-3-5 .....     | Aerosol filter 20 scfm; 1/2" NPT conn; 150 psi                     |
| 2151-3-5 .....     | Aerosol filter 200 scfm; 2" NPT conn; 300 psi                      |
| 2160-6-5 .....     | Aerosol filter 100 scfm; 1" NPT conn; 300 psi                      |
| 2201-12-12-1 ..... | Disposable Aerosol Strainer 2 scfm; 1/4" NPT Male-to-Male          |
| 2420-1 .....       | Triple-Guard Mainline Filter 350 scfm; 3" weld stub; 250 psi       |
| 2420-3 .....       | Triple-Guard Mainline Filter 350 scfm; 3" 150 lb. flange; 250 psi  |
| 2420-8 .....       | Triple-Guard Mainline Filter 350 scfm; 3" 300 lb. flange; 300 psi  |
| 2421-1 .....       | Triple-Guard Mainline Filter 500 scfm; 3" weld stub; 250 psi       |
| 2421-3 .....       | Triple-Guard Mainline Filter 500 scfm; 3" 150 lb. flange; 250 psi  |
| 2421-8 .....       | Triple-Guard Mainline Filter 500 scfm; 3"-300 lb. flange; 300 psi  |
| 2440-1 .....       | Triple-Guard Mainline Filter 750 scfm; 3" weld stub; 250 psi       |
| 2440-3 .....       | Triple-Guard Mainline Filter 750 scfm; 3" 150 lb. flange; 250 psi  |
| 2440-8 .....       | Triple-Guard Mainline Filter 750 scfm; 3"-300 lb flange; 300 psi   |
| 2441-1 .....       | Triple-Guard Mainline Filter 1000 scfm; 3" weld stub; 250 psi      |
| 2441-3 .....       | Triple-Guard Mainline Filter 1000 scfm; 3" 150 lb. flange; 250 psi |
| 2441-8 .....       | Triple-Guard Mainline Filter 1000 scfm; 3"-300 lb flange; 300 psi  |
| 4532-32 .....      | Visi-Guard Filter/Dryer 10 scfm; moisture bullseye; manual drain   |
| 4532-32T .....     | Visi-Guard Filter/Dryer 10 scfm; moisture bullseye; auto drain     |
| 4580-19 .....      | Air-Guard 20 scfm filter; manual drain; 1/2" NPT conn; 150 psi     |
| 4580-19T .....     | Air-Guard 20 scfm filter; auto drain; 1/2" NPT conn; 150 psi       |
| 6543-23 .....      | Desiccant Moisture Indicator; 1/2" NPT conn                        |
| 6543-3 .....       | Desiccant Moisture Indicator; 1/4" NPT conn                        |
| 6543-31 .....      | Desiccant Moisture Indicator; 3/8" NPT conn                        |
| 9450-3 .....       | Air-Guard 100 scfm filter; manual drain; 2" NPT conn; 300 psi      |
| 9450-4 .....       | Air-Guard 150 scfm filter; manual drain; 2" NPT conn; 300 psi      |
| 9450-5 .....       | Air-Guard 200 scfm filter; manual drain; 2" NPT conn; 300 psi      |
| 9450-7 .....       | Air-Guard 100 scfm filter; manual drain; 2" NPT conn; 150 psi      |
| 9450-7T .....      | Air-Guard 100 scfm filter; auto drain; 2" NPT conn; 150 psi        |
| 9450-8 .....       | Air-Guard 150 scfm filter; manual drain; 2" NPT conn; 150 psi      |
| 9450-8T .....      | Air-Guard 150 scfm filter; auto drain; 2" NPT conn; 150 psi        |
| 9450-9 .....       | Air-Guard 200 scfm filter; manual drain; 2" NPT conn; 150 psi      |
| 9450-9T .....      | Air-Guard 200 scfm filter; auto drain; 2" NPT conn; 150 psi        |

continued on page 12

**Obsolete King Filters & Accessories (continued)**

|             |  |
|-------------|--|
| U204 .....  | Ultra-C Color Change (single stage polisher); 20 scfm                |
| U800 .....  | Ultra-C single stage filter 80 scfm; manual drain                    |
| U801H ..... | Ultra-C single stage filter 80 scfm; auto drain                      |
| U801L ..... | Ultra-C single stage filter 80 scfm; low press auto drain            |
| U4003.....  | Sump w/ manual drain; replace with 3277-7                            |
| U4004.....  | Upper bowl; replace with 3277-8                                      |
| U5000.....  | Ultra-C auto drain; replace with 2465-36 for U800 (80 scfm) filters. |

**Service Parts & Dimensions Sheets**

|  | <b>Reference No.</b> |
|--|----------------------|
| 2 SCFM Aerosol Strainer; 2201-14-12-1,<br>2201-32-12-1, 2201-34-12-1 ..... | 6000-2.00            |
| 12 SCFM Ultra-C Color Change Filter; U122, U123.....                       | 6000-20.00           |
| 20 SCFM Air-Guard Bronze Filter; 9313-24, -24T.....                        | 6000-1.00            |
| 20 SCFM Air-Guard Filter; 4525-19, -19T.....                               | 6000-1.03            |
| 20 SCFM Ultra-C Filter; U200, U201, U202, U203 .....                       | 6000-23.00           |
| 60 SCFM Air-Guard Filter; 9460-3, -3T.....                                 | 6000-60.00           |
| 80 SCFM Air-Guard Filter; 2479-1, -1T.....                                 | 6000-80.00           |
| 100 SCFM Air-Guard Filter; 2260-1, -1T.....                                | 6000-100.00          |
| 100 SCFM Aerosol Filter; 2160-3-5.....                                     | 6000-100.50          |
| 350 SCFM Triple-Guard Filter; 2420-3.....                                  | 6000-350.00          |
| 500 SCFM Triple-Guard Filter; 2421-3.....                                  | 6000-350.00          |
| 750 SCFM Triple-Guard Filter; 2440-3.....                                  | 6000-750.00          |
| 1000 SCFM Triple-Guard Filter; 2441-3.....                                 | 6000-750.00          |
| 1 SCFM Special Vacuum Service Dryer; 2002-1 .....                          | 6000-2.20            |
| 2 SCFM Visi-Guard/Metl-Guard Dryer; 1734-2, -6.....                        | 6000-2.10            |
| 12 SCFM Visi-Guard/Metl-Guard Dryer; 1716-6, -10.....                      | 6000-12.00           |
| 12 SCFM Visi-Guard Filter/Dryer; 4532-23, -23T.....                        | 6000-1.09            |
| 12 SCFM Metl-Guard Filter/Dryer; 1784-15, -15T.....                        | 6000-1.20            |
| Air Line Moisture Indicator; 1743-41.....                                  | 7000-1.00            |
| Auto Drain Assembly; 2465-31, -36.....                                     | 7000-2.00            |
| Metal Shatterguard; 3255-30-1 .....  | 7000-4.00            |
| Pressure Regulators; 7840, 7842, 7848, 7849.....                           | 7000-5.00            |