

Sensor Mounting Shells and Adapters

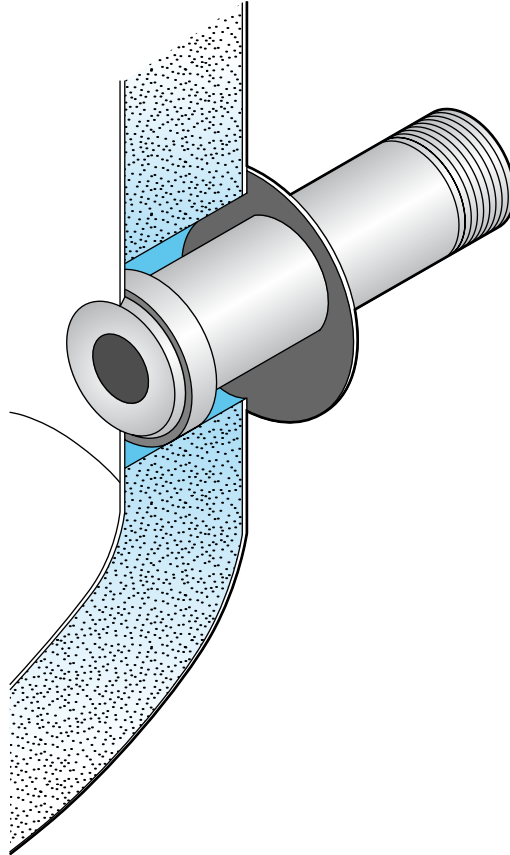

Part Numbers and Applications

Guide to Tank Mounting Shells and Retrofit Adapter Inserts for use with King-Gage® AcraSensor and ES2 Transmitter.

KING-GAGE Mounting Shells/Adapters:

- Flush Weld Tank Shellspage 2
- 2 in. Tri-Clamp Adapter.....page 3
- 2 in. Pipe Mount Adapter.....page 4
- Flange Mount Adapterpage 4

Flush Mount Conversions:

- Cherry Burrell Retrofit Adapter.....page 5
- Tank-Mate Retrofit Adapterpage 5
- Foxboro, Rosemount (Emerson) Adapter ..page 6
- Wizard, Floe, Continental Adapter.....page 6
- Anderson Instr. Retrofit Adapter.....page 7

Sensor Mounting Shells and Adapters

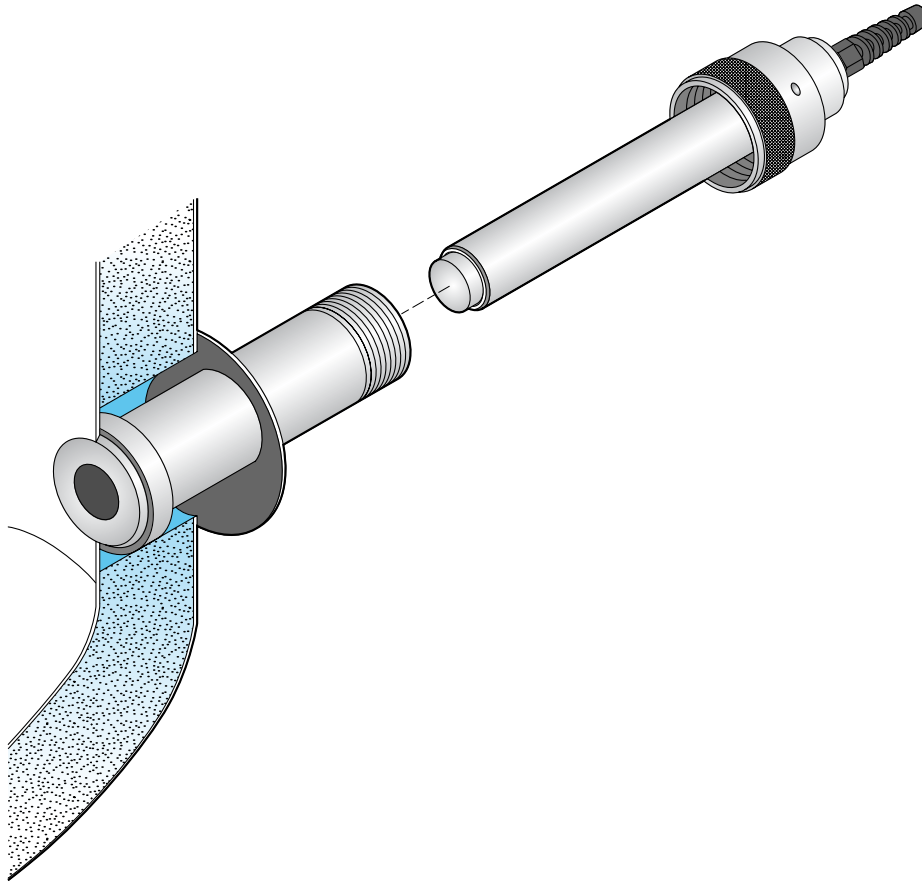

Flush Weld Tank Shells

Receiver for sensor is designed to be flush-welded to the inside tank wall. Provides for flush mounting of sensor in accordance with 3-A Sanitary Standard for CIP (clean-In-Place) installation. Wetted face of shell 316L stainless; all other portions 304 stainless.

Insulated Tank Wall:

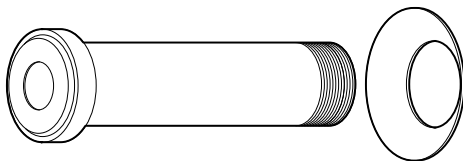

Receiver for sensor is designed to be flush-welded to the inside tank wall. Provides for flush mounting of sensor in accordance with 3-A Sanitary Standard for CIP (clean-in-place) installation.

Part Number	Wetted Material	Max. Tank Wall	Length	
1777-2	Short Mount 316L stainless steel	n/a	1-7/8 in.	48 mm
1777	Standard Mount 316L stainless steel	4-1/2 in.	6-1/4 in.	159 mm
1777-3	Long Mount 316L stainless steel	6-3/4 in.	8-1/2 in.	216 mm

• Insulated tank shells include trim bezel for outer wall

2 in. Tri-Clamp Adapter

External mount adapter mates to Tri-Clover MP-2 in. quick-release sanitary fitting. Adapter package does not include gasket or clamp assembly. Wetted face of shell 316L stainless steel; all other portions 304 stainless steel.

Part Number	Wetted Material	Length	
1749-25	316L stainless steel	1-7/8 in.	48 mm
1749-27	316L stainless steel	6-1/4 in.	159 mm

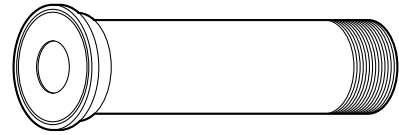

External mount adapter mates to Tri-Clover MP-2" quick release sanitary fitting. Adapter package does not include gasket or clamp assembly. Compatible with ES2 Model 5501 or AcraSensor Model 4501 / 8999-1-3 (short adapter); compatible with ES2 Model 5502 or AcraSensor Model 4502 / 8999-2-3 (standard adapter).

Shell Welding Protector

These shell inserts are used to protect the face of the King shell during the welding and grinding/blending operations.

Part Number	Description
5664-1	Shell Welding Protector

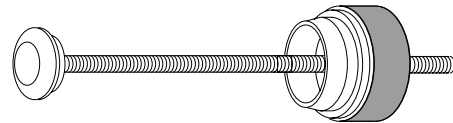

These shell inserts are used to protect the face of the King Shell during the welding and grinding/blending operations.

Shell Plug

Used to seal an installed tank shell or adapter. Permits use of tank prior to sensor installation or when sensor is removed for service.

Part Number	Applications
2584-4	King non-insulated shell (short mount)
2584-3	King insulated shell (standard mount) King flange-mount shells Tank-Mate adapter (short) Cherry-Burrell adapter (short) Cont./Floer/Wizard adapter Foxboro/Rosemount (short)
2584-6	King insulated shell (long mount) Tank-Mate adapter (long) Cherry-Burrell adapter (long) Foxboro/Rosemount (long)

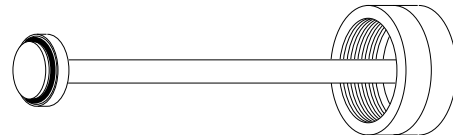

Used to seal an installed tank shell or adaptor. Permits use of tank prior to sensor installation or when sensor is removed for service.

Pipe Mount Adapter Shells

Mounting adapter mates to 2 in. NPT pipe thread. Specify whether male (NPT-M) or female (NPT-F) adapter is required. Available in 304 stainless steel only.

Part Number	Adapter Thread	Length	
5872-1-2	2 in. NPT-M	7-3/4 in.	197 mm
5872-2-2	2 in. NPT-F		

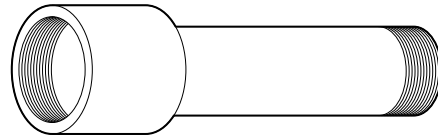
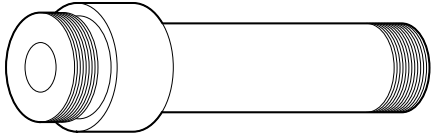

Compatible with ES2 Model 5502 standard mount transmitter or AcraSensor Model 4502 / 8999-2-3 standard mount package. Mates to 2" NPT common tapered pipe thread.

Flange Mount Adapter

Adapter mates to 150-lb. ANSI flange (2 in., 3 in., or 4 in. sizes available). Adapter has flat-faced flange 316L stainless steel. Gasket and bolt fasteners are not included.

Part Number	Flange Size/ Material	Length	
5627-3	2 in.-150 lb./316L stainless steel	6-1/2 in.	159 mm
5627-13	3 in.-150 lb./316L stainless steel	6-1/2 in.	159 mm
5627-23	4 in.-150 lb./316L stainless steel	6-1/2 in.	159 mm

Compatible with ES2 Model 5502 standard mount transmitter or AcraSensor Model 4502 / 8999-2-3 standard mount package. Adapter mates to 150-lb ANSI flange (2", 3" or 4" sizes as noted). Gasket and bolt fasteners are not included.

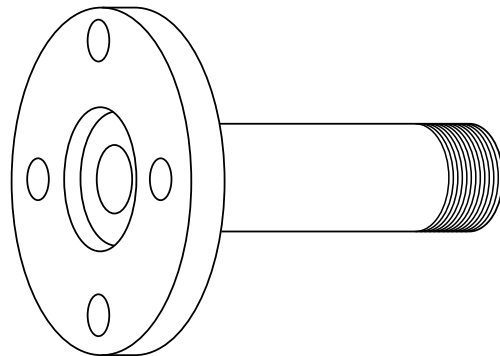

Flush Mount Conversion Adapters

Specially designed adapter inserts permit retrofit installation of sensor into existing flush mount shell by other manufacturers. Adapters available in 304 stainless steel only.

Note: We recommend verifying existing shell configurations for dimensional compatibility with intended conversion adapter.

Short Cherry-Burrell adapter is compatible with ES2 Model 5502 standard mount transmitter or AcraSensor Model 4502 / 8999-2-3 standard mount package.

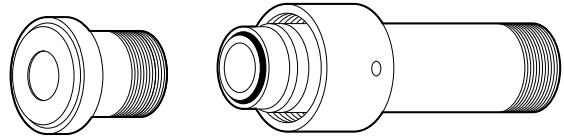

Long Cherry-Burrell adapter is compatible with ES2 Model 5503 long mount transmitter or AcraSensor Model 4503 / 8999-3-3 long mount package.

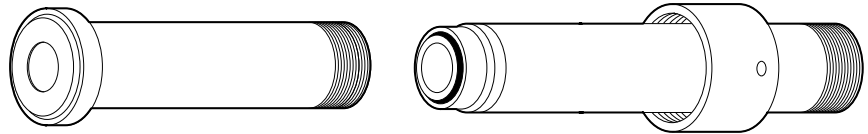

Cherry-Burrell Conversion Adapters

Manufacturer	Part Number	Length		Retrofit Application	King Sensor
Cherry-Burrell	5640-1	6-1/4 in.	159 mm	Short/Non Insulated	Standard
	5640-2	8-1/2 in.	216 mm	Standard/Insulated	Long

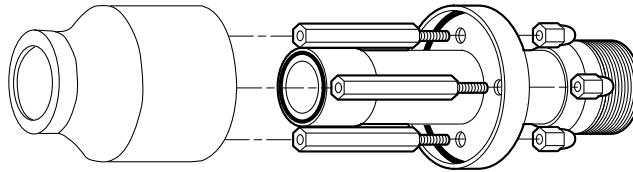

Short Tank Mate adapter is compatible with ES2 Model 5502 standard mount transmitter or AcraSensor Model 4502 / 8999-2-3 standard mount package.

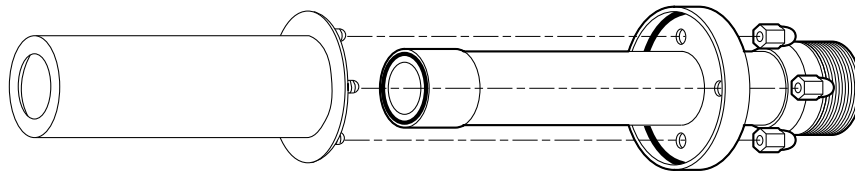

Long Tank Mate adapter is compatible with ES2 Model 5503 long mount transmitter or AcraSensor Model 4503 / 8999-3-3 long mount package.

Tank-Mate Conversion Adapters

Manufacturer	Part Number	Length		Retrofit Application	King Sensor
Tank-Mate	5641-1	6-1/4 in.	159 mm	Short/Non Insulated	Standard
	5641-2	8-1/2 in.	216 mm	Standard/Insulated	Long

- Includes: Acorn nuts (both) and spacers (5641-1 only)

Flush Mount Conversion Adapters (continued)

Standard Foxboro adapter is compatible with ES2 Model 5502 standard mount transmitter or AcraSensor Model 4502 / 8999-2-3 standard mount package.

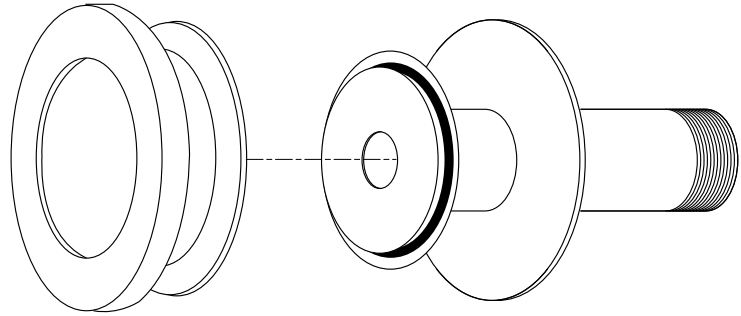

Long Foxboro adapter is compatible with ES2 Model 5503 long mount transmitter or AcraSensor Model 4503 / 8999-3-3 long mount package.

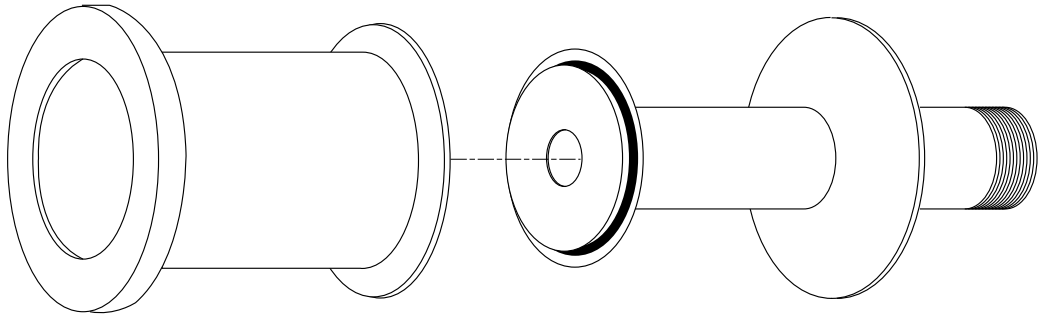

Foxboro Conversion Adapters

Manufacturer	Part Number	Length		Retrofit Application	King Sensor
Foxboro, Rosemount (Emerson)	5905-1	6-1/4 in.	159 mm	2 in. extension spud	Standard
	5905-2	8-1/2 in.	216 mm	6 in. extension spud	Long

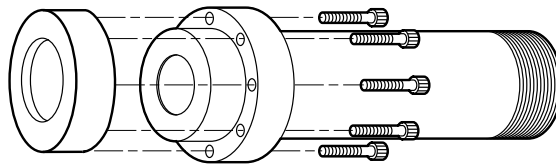

Continental/Floe/Wizard adapter is compatible with ES2 Model 5502 standard mount transmitter or AcraSensor Model 4502 / 8999-2-3 standard mount package. Adapter includes cap screws and O-ring.

Wizard/Continental/Floe Conversion Adapters

Manufacturer	Part No.	Length		Retrofit Application	King Sensor
Wizard/Cont./ Floe	5665-1	6-1/4 in.	159 mm	Insulated Tank or Single Wall Tank	Standard

- Includes: Cap screws

Flush Mount Conversion Adapters (continued)

Short adapter for Anderson Instrument is compatible with ES2 Model 5502 standard mount transmitter or AcraSensor Model 4502 / 8999-2-3 standard mount package.

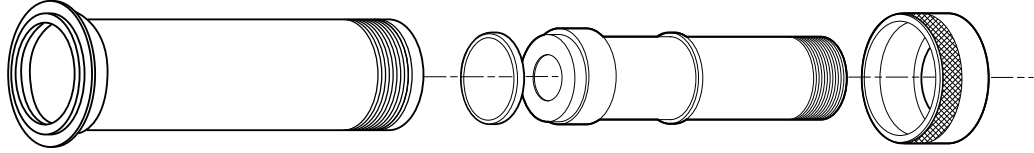

Long adapter for Anderson Instrument is compatible with ES2 Model 5503 long mount transmitter or AcraSensor Model 4503 / 8999-3-3 long mount package.

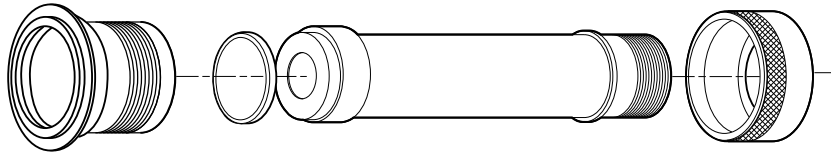

Anderson Conversion Adapters

Manufacturer	Part No.	Length		Retrofit Application	King Sensor
Anderson	5878-1	6-1/4 in.	159 mm	Short/ Non Insulated	Standard
	5878-2	8-1/2 in.	216 mm	Standard/Insulated	Long

- Includes: Clamp ring

AcraSensor and ES2 Transmitter Dimensions

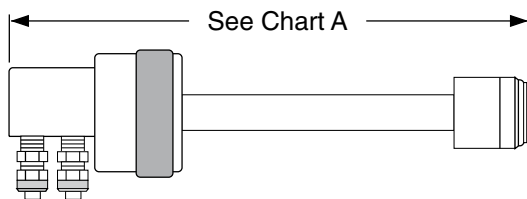

Chart A
AcraSensor

Model Number	Length in Inches	Length in mm	
4501-X-XX 8999-1-3	4	102	short
4502-X-XX 8999-2-3	8-3/8	213	standard
4503-X-XX 8999-3-3	10-5/8	270	long

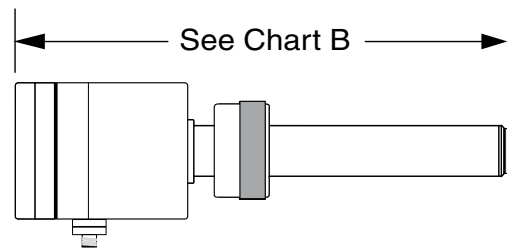

Chart B
ES2 Transmitter

Model Number	Length in Inches	Length in mm	
5501-3-XX 5501-3R-XX	5-5/8	143	short
5502-3-XX 5502-3R-XX	10-1/8	257	standard
5503-3-XX 5503-3R-XX	11-5/8	295	long



3201 South State, Ann Arbor, Michigan 48108 U.S.A.
PO Box 1228, Ann Arbor, Michigan 48106-1228
Phone: 734-662-5691 ▪ FAX: 734-662-6652
www.king-gage.com

® King-Gage and the KE emblem are registered trademarks of
King Engineering Corporation, Ann Arbor, Michigan, U.S.A.

Specifications are subject to change without notice.

© 2001, 2009 King Engineering Corporation, all rights reserved.