

KING-GAGE® Marine Systems

Tank Level and Draft Indicating Systems for the Marine and Offshore Industries

LP2™ Multiple Tank Tank Level Indicator

- Displays Tank Volume and/or Depth
- Nonvolatile Datapack iButton Memory
- 8 Tank Input Channels
- Dual Serial Communications Ports

The new LP2 Multiple Tank indicator combines intelligent signal processing and accurate volumetric measurement. LP2 indicators will provide continuous measurement of liquid levels for ballast, fuel oil, potable water or other service tanks. These units calculate level on the basis of hydrostatic pressure created by liquid depth.

LP2 multiple tank indicators accept up to eight input channels that receive proportional 4-20 mA signals from liquid level transmitters. The actual sensor used to detect hydrostatic pressure (created by liquid depth) can be either electronic or pneumatic. With the latter, an electronic pressure transmitter is used to convert the sensor's pneumatic signal into 4-20 mA output (using a KING-GAGE® D/P Module or D/P Transmitter).

LP2 indicators express tank level directly in engineering units. The indicator references a capacity profile to correlate transmitter output to actual tank geometry. The indicator then formats the resulting value directly as the total weight or volume of liquid in the tank. As an operator interface, the keypad provides access to function selection and density adjustments. There are no user conversion factors involved or scaling points to enter. All application details are factory programmed into an innovative nonvolatile modular memory called the *Datapack iButton*.



LP2™ Multiple Tank Indicator

Applications Include:

- Ship's Draft
- Ballast Water Tanks
- Fuel Oil Tanks
- Day Tanks
- Bunker Oil Tanks
- Drill Water Tanks
- Lube Oil Sump Tanks
- Inner Bottom Tanks
- Liquid Cargo Tanks



Surface Mount Enclosure
Rugged corrosion proof housing for bulkhead mounting (requires 100-240 Vac electrical connection).



Flush Mount Panel
Flush stainless steel panel for console mounting (see mounting dimensions on page 4).

Typical Ballast Tank Indicating System

788 Purge Control supplies air to downpipe in tank. Pressure created due to liquid depth generates a proportional 4-20 mA output signal from the transmitter. The LP2 indicator calculates the actual tank level (or volume amount).

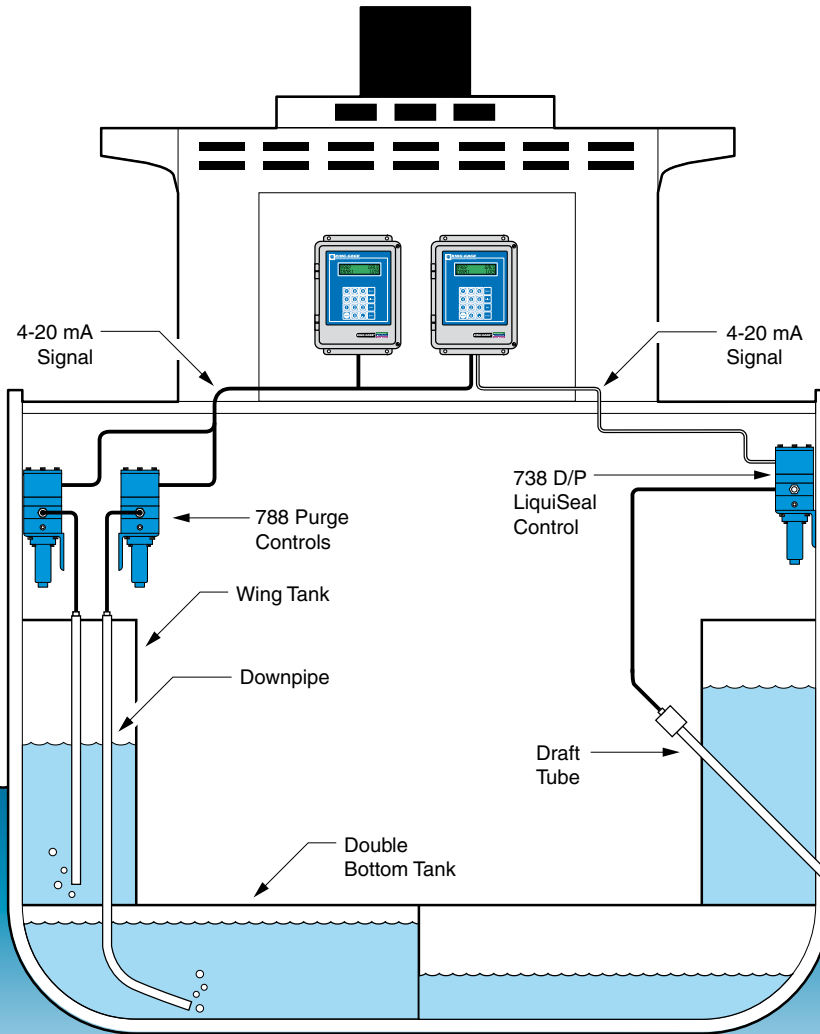

Typical Draft Indicating System

738 D/P LiquiSeal Sensor provides air purge to draft tube. Pressure created within tube is sensed by sensor which outputs a proportional 4-20 mA signal. Corresponding draft level is shown on the LP2 indicator.

LP2 Tank Level and Draft Indicating Systems

The local operator interface panel permits direct entry of density values, supervisory password protection, manual and automatic scanning display modes. An alphanumeric LCD panel provides 10-character tank identification with 8-digit display value and current density selection.

Dual serial ports support multiple network configurations including query-response communications with a computer (or automated control system), remote satellite displays.

Application Programming

The LP2 indicator references a capacity profile to correlate transmitter output to actual tank geometry. This profile plus additional application details are factory programmed into an innovative nonvolatile Datapack iButton memory module. Different units of measurement and/or specific gravity values can be assigned to each tank in the system. LP2 stores all the user selections in its Datapack iButton memory. The more critical data is restricted to read only access to prevent any possible corruption of the original factory programming.

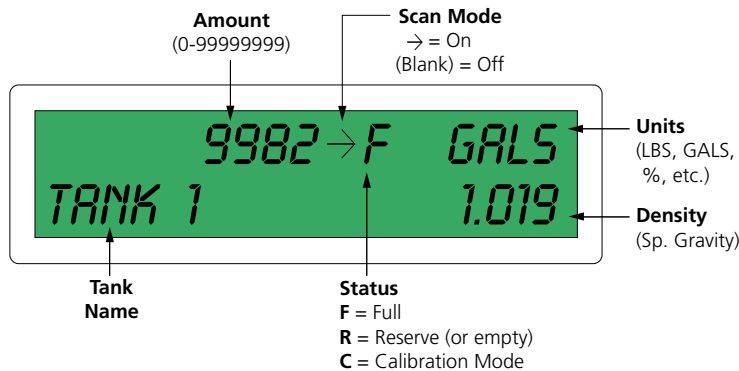

Specifications

Power Requirements

100-240 Vac, 50-60 Hz, 25 watts (fused internally for 2.5 A 120/250 V)

Temperature Range (Environmental)

30°F to 120°F (0°C to 50°C) operating range

Signal Input

4-20 milliampères (mAdc)

Input Channels

8 input channels; two wire 4-20 mA analog signal

Keypad

Membrane numeric keypad, five (5) function keys, positive tactile response

Power Output

24 Vdc nominal; fused @ 0.5 Amp

Input Impedance (Resistance)

120 ohm nominal (2.4 Vdc drop @ 20 mAdc)

Memory

Nonvolatile 64kbit memory iButton*

Digital Readout

Alphanumeric 0.3173 in. (8 mm) 16-character x 2-line LCD; numeric 8-digit (0-99999999 maximum)

Accuracy

±0.048% FS (±0.024% FS, typical)

Resolution

±0.024% FS maximum (±0.004 mA)

Communications

Two (2) serial EIA RS-485 ports; two wire multidrop

You can view tank input channels either by scanning or random access. Press the desired channel number directly to view tank level. To continue viewing tank channels in sequential order, simply press SELECT to view the next channel. Holding the key down for 3-seconds initiates the auto scroll mode for all tank channels. Press any key to restore normal single channel display mode.

The user interface of the LP2 is extremely easy to operate. Simply press the MENU key to cycle through options such as Display Unit selection, Specific Gravity input, Calibration mode and Password Access (to restrict specific gravity entry).

Menu Display Modes

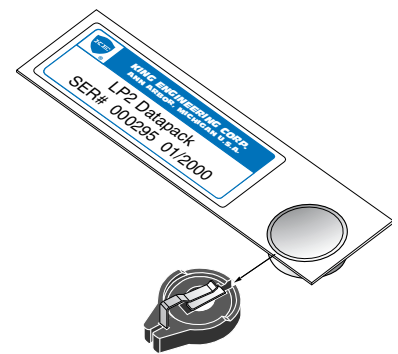
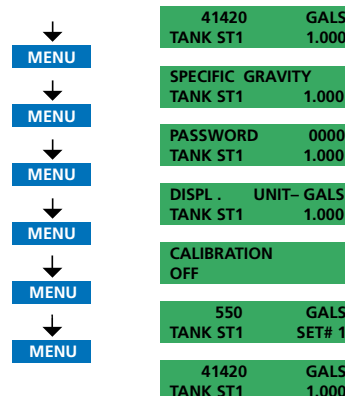

Datapack iButton

KING-GAGE® Marine Systems

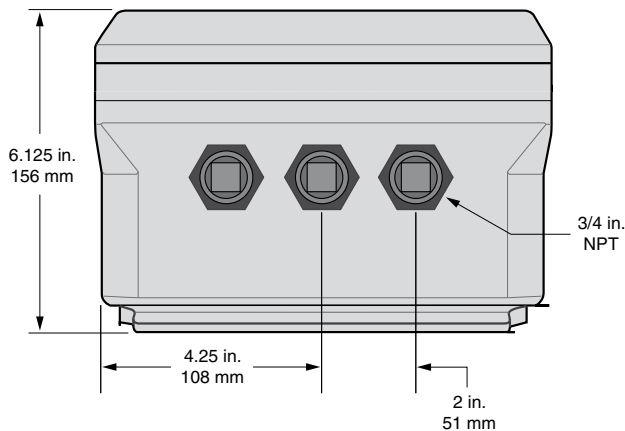
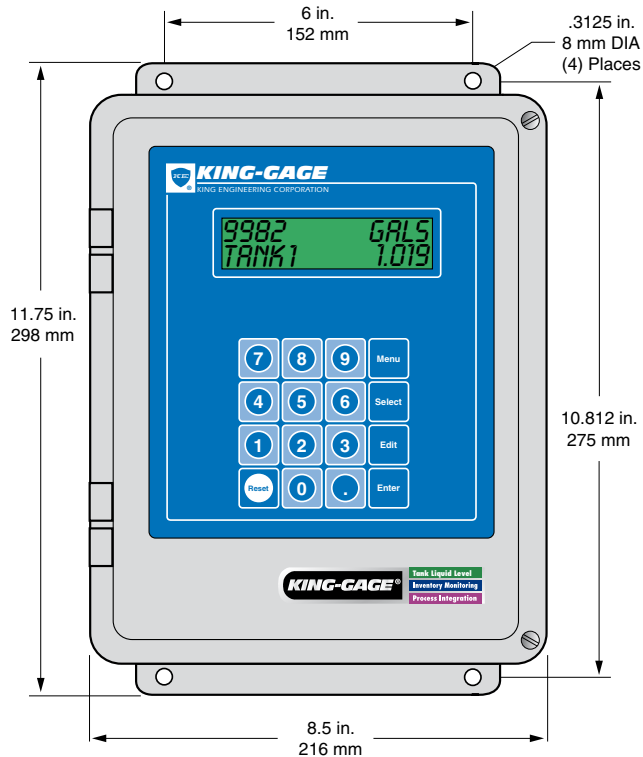

Model 4641-2-0

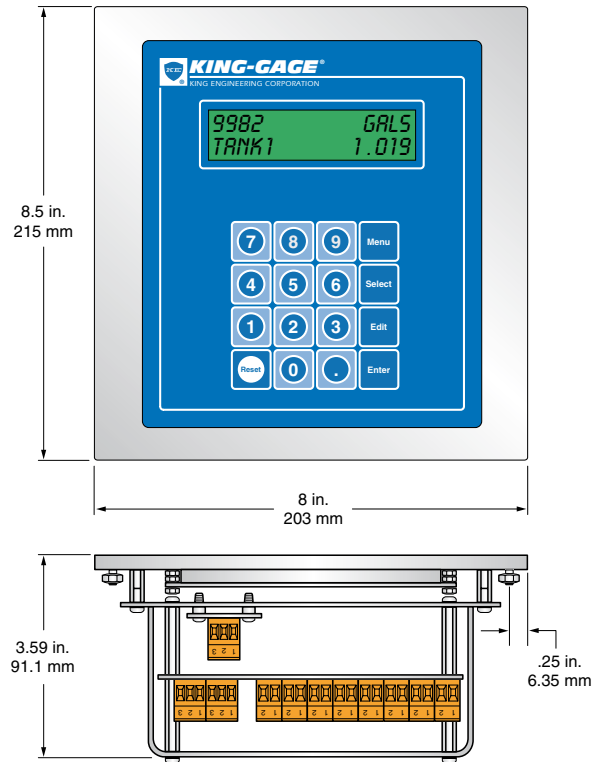

Model 4641-4-0

■ **Enclosures**

Shown: Engineered thermoplastic (NORYL) enclosure; UL 50, NEMA type 3, 3S, 4, 4X, 12; hinged cover with dual latching screws.

Optional: 14 gauge stainless steel enclosure; UL 50 type 4, 4X, 12, 13; hinged cover with dual latching screw lugs.

Also Shown: Flush mount; 11 gauge stainless steel plate, 2B finish; closed cell neoprene gasket; aluminum rear cover housing.



3201 South State, Ann Arbor, Michigan 48108 U.S.A.
 PO Box 1228, Ann Arbor, Michigan 48106-1228
 Phone: 734-662-5691 • FAX: 734-662-6652



www.king-gage.com

© KING-GAGE and the KE emblem are registered trademarks of King Engineering Corporation, Ann Arbor, Michigan U.S.A.

All specifications are subject to change without notice.
 © 2008 King Engineering Corporation, all rights reserved.