

KING-GAGE® Marine Systems

Tank Level and Draft Indicating Systems for the Marine and Offshore Industries

LevelBAR HP Marine Tank Level Indicator

- Self-Contained Hand Pump System
- On Demand Monitoring of Tank Level
- Individually Calibrated Indicator Scale

The **KING-GAGE LevelBAR HP** bright multi-segment LED column provides graphic indication of level for shipboard tanks applications. This self contained unit is actuated by an integral hand pump to pressurize the system. It will provide on-demand monitoring of tank level by measuring hydrostatic pressure created by liquid depth. The LevelBAR HP is applicable to ballast, fuel oil, waste water, and other shipboard tanks.

All LevelBAR indicators include a custom graduated tank level scale in units of total volume, weight, or depth of the liquid contents. A backlighting feature makes the scale readable in the absence of ambient illumination while the red LED column is viewable even in bright daylight. LevelBAR t indicator can be used as a direct replacement for mercury tank gauges or other fluid-filled manometers.

This unit is well adapted for service on marine vessels and offshore rigs. Rugged stainless steel housing resists corrosion while affording suitable protection for the internal electronics and intended to meet splash proof requirements. The use of waterproof conduit hubs or fittings may be required during installation. Not rated for continuous explosion hazard areas.

Simple proven principle employs a hand pump to supply air which fills the pipe. The resulting pressure created (within the pipe) and sensed by the indicator is directly proportional to liquid depth.

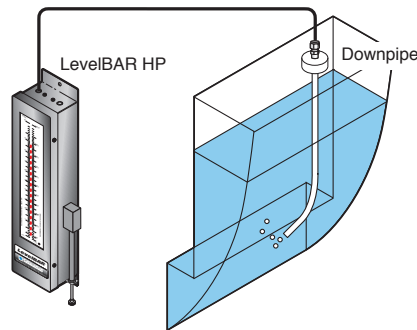

LevelBAR Hand Pump System



KING-GAGE® Marine Systems

LevelBAR HP Custom Scale

Scales are calculated for the individual tank geometry and product specific gravity permitting the LevelBAR HP system to be used for almost any kind and shape of tank, including wing or void tanks. Each is custom marked in any specified unit of measurement (gallons, pounds, liters, short tons, etc.). An optional 2-unit scale can be specified to combine any two different measurements such as weight and volume, or volume and depth.

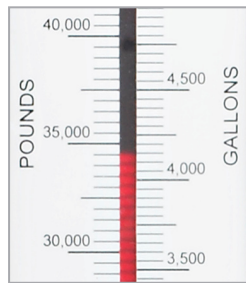

Specifications

Display Accuracy/Resolution

1%

Display Type

100-segment LED (light emitting diode)

Display Length

10"/254 mm

Input Power

100–240 Vac, 50/60 Hz

Temperature Range (Environmental)

30°F to 120°F (-1°C to 49°C) operating range

Pressure Ranges

0–5, –10, –15, –30 psid fixed range transmitter element (accepts clean, dry air/gas pressure input). Maximum pressure rating is 300% FS.

Minimum pressure range for proper operation is 50% of nominal. The lowest acceptable input pressure range is 0–2.5 psid using the 0–5 psid transducer element.

Pressure Accuracy

0.5% FS

Physical Data

304 stainless steel housing and cover with gasket seal, transparent polycarbonate display window. Intended to meet splash proof requirements. The use of waterproof conduit hubs or fittings may be required during installation. Not rated for continuous explosion hazard areas.

Model No. Designations

5111-3

- 0 = pneumatic D/P input (0–5 psid pressure range)
- 1 = pneumatic D/P input (0–10 psid pressure range)
- 2 = pneumatic D/P input (0–15 psid pressure range)
- 3 = pneumatic D/P input (0–30 psid pressure range)

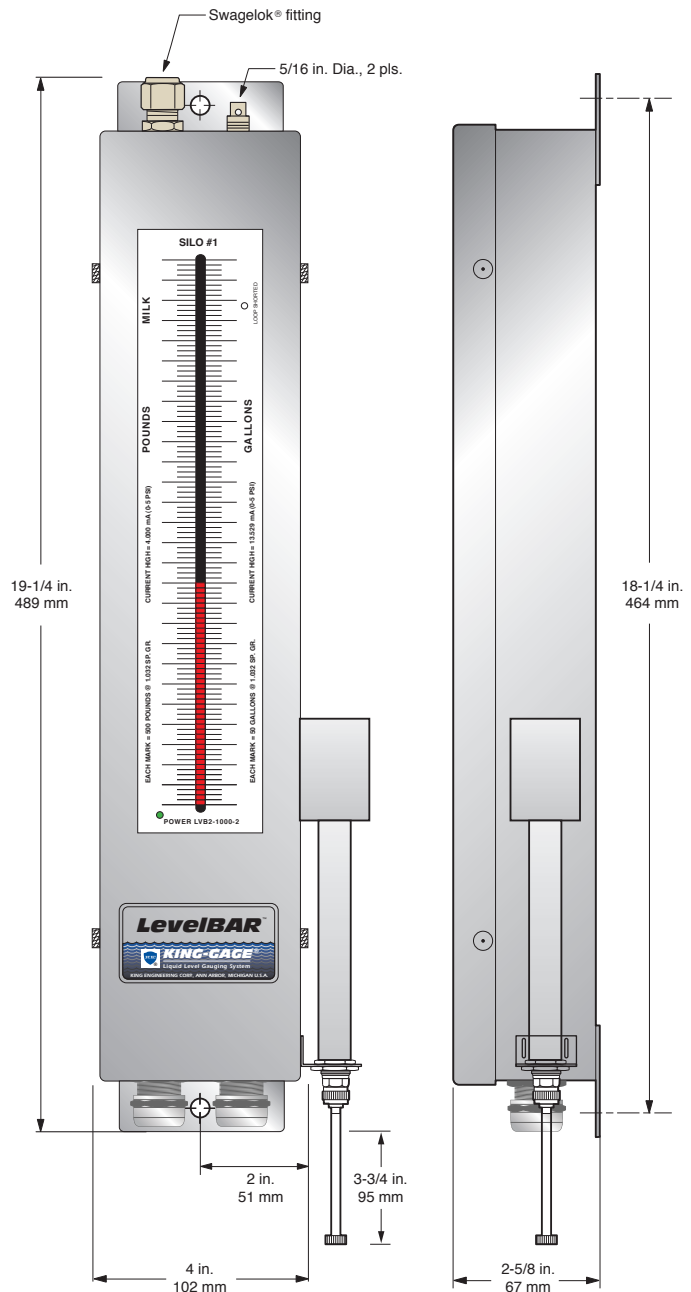

3201 South State, Ann Arbor, Michigan 48108 U.S.A.
PO Box 1228, Ann Arbor, Michigan 48106-1228
Phone: 734-662-5691 • FAX: 734-662-6652



www.king-gage.com

© KING-GAGE and the KE emblem are registered trademarks of King Engineering Corporation, Ann Arbor, Michigan U.S.A.

All specifications are subject to change without notice.
© 2010 King Engineering Corporation, all rights reserved.