

**Sensor Mounting (Tank Shell)**

The tank shell provides for the physical installation of the sensor to the tank. The sensor must penetrate the tank lining to permit direct contact with the liquid contents. The tank shell should be installed as close to the bottom of the tank as practical. The physical location should allow adequate clearance (minimum of 6 inches) for installation/removal of sensor probe.

Shell is available in three (3) lengths to accommodate various tank wall thickness. See Figure 5-7.

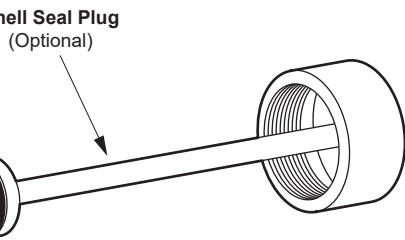
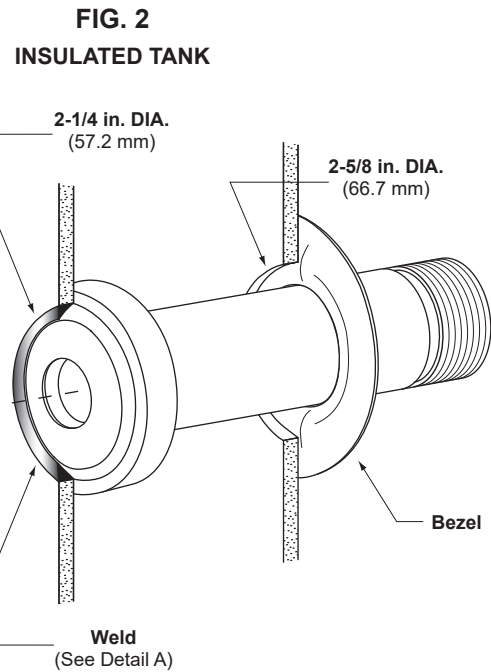
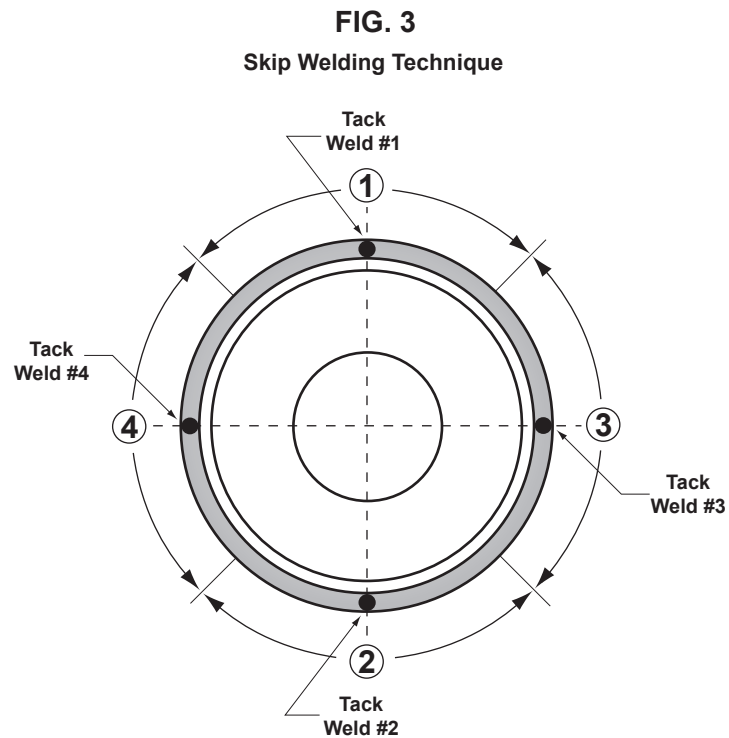

**Shell Seal Plug**

- Part No.**
- 2584-4 Short Length Plug Assy
  - 2584-3 Standard Length Plug Assy
  - 2584-6 Long Length Plug Assy

Plug assembly is intended to seal the opening at the tank wall of a KING-GAGE tank shell or adapter fitting. It permits use of the tank or processing vessel when the sensor has been removed or prior to sensor installation. Flush face and silicone rubber O-ring make installed plug assembly compatible with CIP tank cleaning process.

**TANK SHELLS**

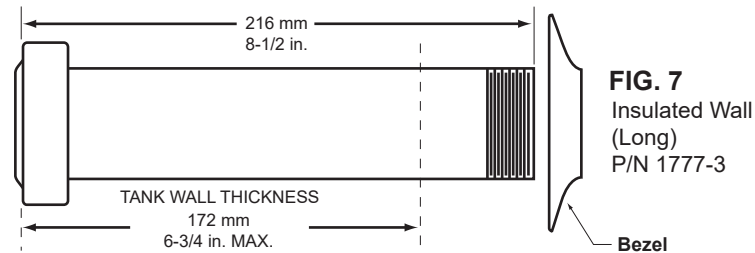
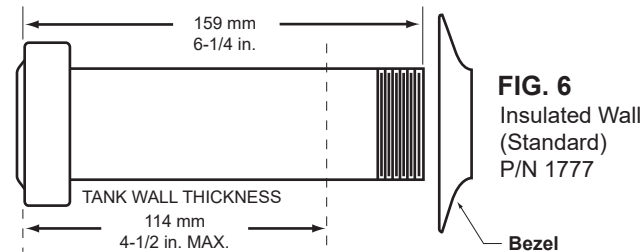
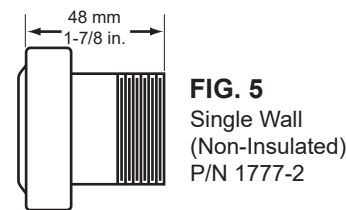

**Insulated Tank Wall -** machine a 2-1/4 in diameter hole (+1/32 in, -0 in tolerance) through the inner wall or liner. A second larger hole of 2-5/8 in diameter is required through the outer wall that will accommodate the larger welding flange end. Refer to Figure 2.

**Single Wall (Non-Insulated Tank) -** machine a 2-1/4 in diameter hole (+1/32 in, -0 in tolerance) through the tank wall. Refer to Figure 1.

**WELDING SHELL TO TANK**

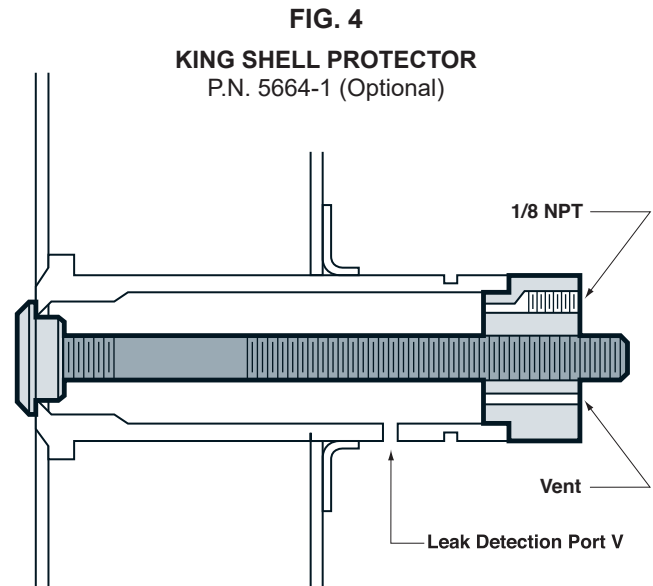

**Welding Procedure**

**CAUTION!** Excessive heat buildup during welding may warp tank shell and prevent proper seating of sensor. Position leak detection port downward during shell installation.

1. Tack weld the shell to the inner wall at several opposing points around the hole (see Figure 3).
2. Use small filler rod and make short welding passes (approx. 1-2 inches) and alternate between opposing points around the circumference. This will help to evenly distribute heat buildup over the flange end to avoid warping it.
3. Allow weld area to cool completely before blending/grinding the bead flush to the tank wall. We recommend using a plug or protector to guard against damaging the opening for the probe (see note below).
4. Insulated Tanks - bezel is provided for outer tank lining that may be placed over threaded end of shell and welded in place.

A separate shell protector is available that provides a 1/8 NPT connection for compressed air to cool the shell during the welding procedure. The protector is also intended to protect the opening on the flange end to avoid enlarging or damaging the hole when grinding down the weld bead. (See Figure 4)

**INSTALLATION INSTRUCTIONS**

**Tank Shell Installation and Recommended Welding Procedure**  
(P.N. 1777, 1777-2, and 1777-3)

E	10/10	Detection Port	DATE	10/05/10
D	11/05	Added Dim. mm	DRAWN	D.Kennedy
C	6/00	Redrawn	APP'D	

**KING-GAGE**  
A NOSHOK Company

1010 West Bagley Rd., Berea, Ohio 44017  
Ph 855.367.2494 www.king-gage.com

DWG NO.		<b>K-1060-1-1777</b>
SHEET		
<b>1</b>	OF	<b>1</b>
REV.		<b>E</b>