

Models 735, 738, 780, 788

Effective: January, 2012

DATA SHEET 1200-25

Purge Controls

- Continuous level measurement
- Reliable, proven sensing technique
- Simple to install and maintain

A downpipe is the simplest type of liquid level sensor, often referred to as a "bubbler." This is merely a length of open ended pipe that extends downward into the tank. LiquiSeal™ or Purge Control differential pressure air flow regulators are highly refined versions of the basic bubbler air control.

Downpipe Level Sensor

When purged with compressed air, liquid within the downpipe is displaced by air pressure equal to the hydrostatic force of liquid in the tank. If carefully regulated at a low rate of flow, air pressure will constantly maintain equilibrium against the force of the liquid. Air escapes out through the bottom of the pipe unless needed to increase pressure as liquid force (depth) increases.

The primary sensor element is typically 3/4 in. diameter pipe purchased from a local source. Always select piping material for compatibility with the tank contents. Downpipe purge systems can be used to measure virtually any type of liquid product including resins, asphalt or corrosive materials. Output is proportional to liquid depth and can

be transmitted as an electronic 4-20 mA signal or pneumatically as a direct 1:1 pressure signal.

LiquiSeal™ Purge Control

LiquiSeal D/P purge control is a fully integrated air purge regulator and level transmitter. Operation is based on the control regulating a continuous 1 cfh (cubic foot per hour) flow of compressed air into the tank downpipe. An internal differential pressure sensor element converts resulting pressure into a 4-20 mA dc two wire signal.

An all-pneumatic version of the LiquiSeal purge control is available. It provides a 1:1 pressure signal to a compatible indicator or external transducer through 1/4 in. airline tubing.

All LiquiSeal purge controls feature an internal isolation



diaphragm. Backpressure created by the continuous purging of the downpipe is applied to this internal diaphragm. Working as a pneumatic transmitter, an equivalent pressure is generated on the gauge side of the diaphragm. This process effectively isolates downstream components from contact with the liquid or vapor releases.



780 Series Purge Controls

788 D/P Purge Control is a more basic differential pressure regulator and air flow control. It generates a constant flow of compressed air to purge a downpipe. Its integral differential

pressure transmitter provides 4-20 mAdc output proportional to liquid level. 780 Purge Control is an all-pneumatic version that does not include the integral transmitter. It provides a 1:1 pressure signal to a compatible indicator or external transducer through 1/4 in. airline tubing. The purge control holds a fixed pressure differential across a precision orifice to ensure constant flow rate of 1 cfh (cubic foot per hour). This regulated low flow rate makes it possible to maintain a linear 1:1 response of the sensing system. In this way, backpressure sensed is equivalent to the hydrostatic head pressure due to actual liquid depth.

Pneumatic Output Signal

Purge Control or LiquiSeal Control provides air pressure signal to an external transmitter or compatible indicator (with integral transducer). Typically, 1/4" poly or soft copper tubing is used to convey the pressure signal up to 1000 feet from the tank.

Electronic 4-20 mA Output

D/P Purge Control or D/P LiquiSeal transmitter provides a 4-20 mA output over a two wire cable to an indicator or the analog I/O of a PLC. Using twisted pair shielded cabling permits transmission distances of several thousand feet to a remote receiver.

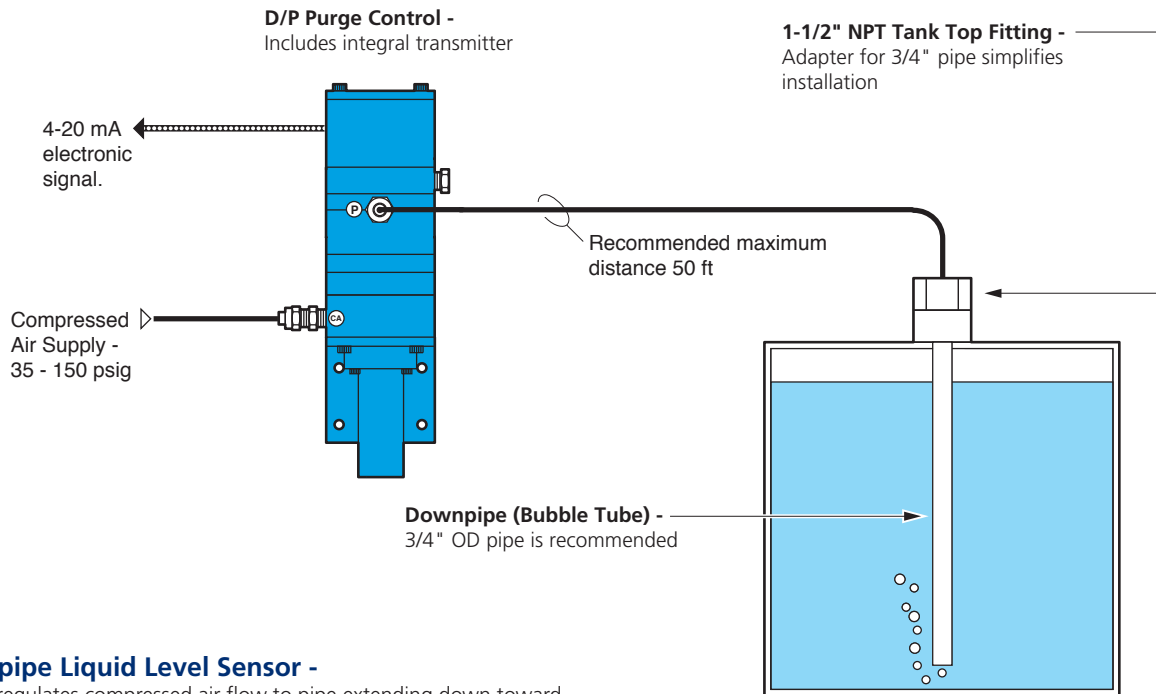

Downpipe Liquid Level Sensor -

Control regulates compressed air flow to pipe extending down toward tank bottom. Depth of liquid causes air pressure to increase or decrease proportionally. A differential pressure (D/P) transmitter provides a 4-20 mA signal that can be used for remote indication or process control functions.

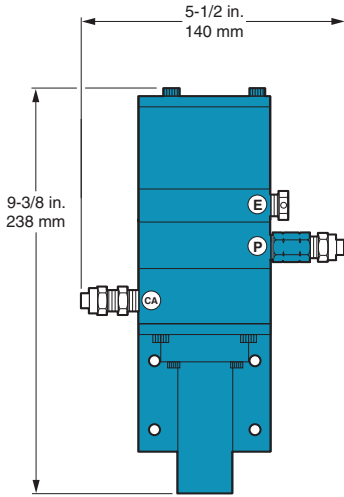

Model 788
D/P Purge Control

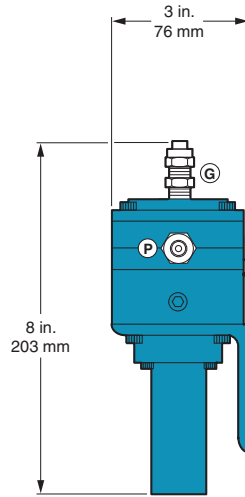

Model 780
Purge Control

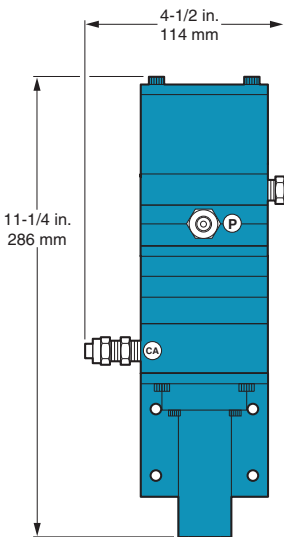

Model 738
D/P LiquiSeal Control

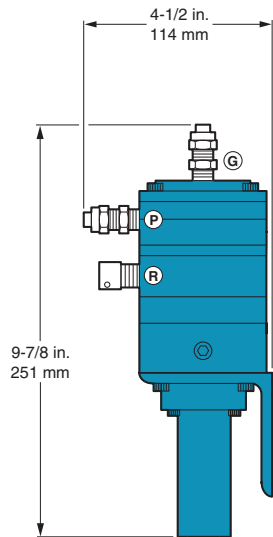

Model 735
LiquiSeal Control

SPECIFICATIONS

Accuracy

- 0-5 psid trans./control..... ± 0.34% FS
- 0-10 psid trans./control..... ± 0.27% FS
- 0-15 psid trans./control..... ± 0.24% FS
- 0-30 psid trans./control..... ± 0.22% FS
- 0-50 psid trans./control..... ± 0.21% FS

Repeatability

± 0.20% of calibrated span

Temperature Range

0 to 120°F / -16 to 54°C

Maximum Pressure

300% overrange

Burst Pressure

200 psig

Power Supply Voltage

14-40 Vdc (unregulated)

Compressed Air Requirement

35-150 psig supply pressure at control inlet. (Minimum supply pressure should be at least 20 psig greater than anticipated maximum liquid head pressure.)

Maximum Depth Measurement

1,937 in. water (49.0 m)

Purge Control

Unit incorporates differential air flow regulator with flow control orifice. Fixed differential set to nominal 10 psid. Output is 1:1 pneumatic pressure (hydrostatic force equivalent).

D/P Purge Control

Same as the above model but adds an integral differential pressure (D/P) transmitter converting pneumatic pressure into 4-20 mAdc electronic output. Ranges available: 0-5, -10, -30, -50 psid

Flow Rate (Air Purge)

Nominal 1 cfh (cubic feet per hour) at specified differential. Maximum air consumption under 5 cfh.

Material of Construction

Machined brass body with acrylic semi-gloss enamel finish; integral filter element is aluminum with acrylic semi-gloss enamel finish.

SafeGard Option (780 Purge Control)

An adjustable pressure-limiting control that permits pre-setting a maximum value for pressure output from the Purge Control. SafeGard range available as 25" to 650" water or 650" to 1750" water.

Span Adjustment Range

Transmitter turndown ratio is 3:1 for the 0-15, 0-30, 0-50 psid nominal ranges.

Nominal Minimum Range of Adjustment

0-5 psid	0-3 psid	0-83 in. thru 0-138 in. water/0-2.1 m thru 0-3.5 m water
0-10 psid	0-3 psid	0-83 in. thru 0-277 in. water/0-2.1 m thru 0-7.0 m water
0-15 psid	0-3 psid	0-83 in. thru 0-415 in. water/0-2.1 m thru 0-10.5 m water
0-30 psid	0-10 psid	0-277 in. thru 0-830 in. water/0-7.0 m thru 0-21.0 m water
0-50 psid	0-15 psid	0-415 in. thru 0-1384 in. water/0-10.5 m thru 0-35.1 m water

IMPORTANT! Accuracy, linearity, and non-repeatability values are based on nominal range.

Operating Limit (Maximum Pressure)

Pressure above 300% nominal range (overrange) will result in damage to the transmitter (200% may cause a shift in calibration). Burst pressure is 200 psi and will cause catastrophic and physical failure of the pressure element.

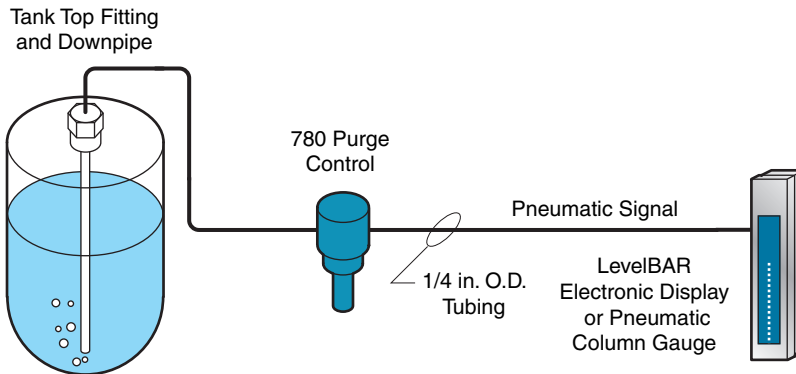

Pneumatic Output to Indicator

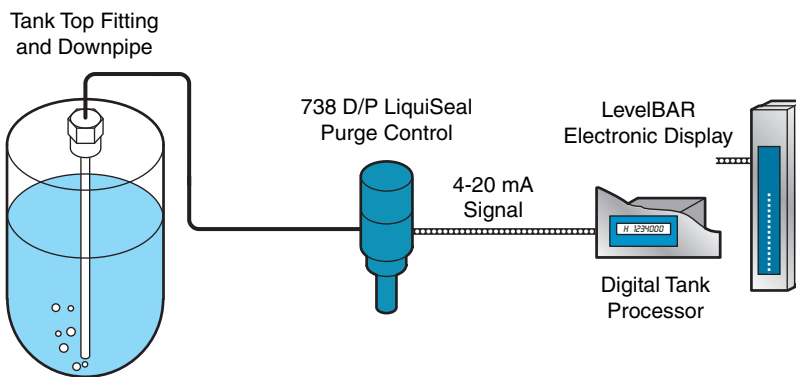

Electronic Output to Indicator

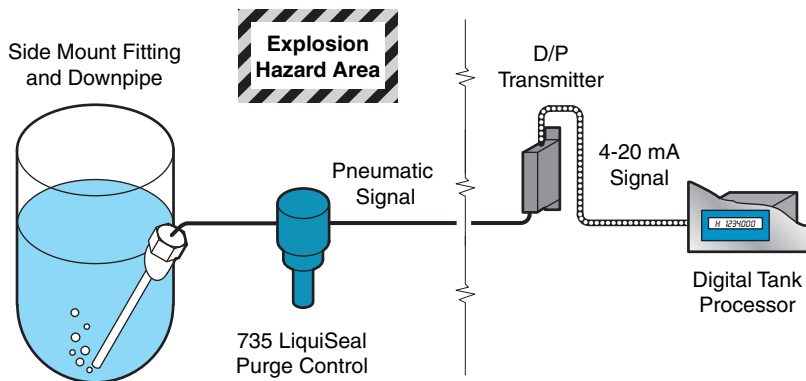

Pneumatic Output to External Transmitter

Tank Gauging Applications

A complete tank level gauging system can be configured using either pneumatic Purge Controls or D/P Purge Controls. The output signal can be routed to either an analog column display or digital readout. Indication is then provided directly as the total weight or volume of liquid in the tank.

Pneumatic Output to Indicator - Purge Control continuously purges tank downpipe and creates pressure corresponding to hydrostatic head of liquid. This pressure signal is conveyed through 1/4 in. airline tubing to a compatible electronic or pneumatic column indicator.

Electronic Output to Indicator - D/P Purge Control senses hydrostatic pressure due to liquid depth and transmits a proportional 4-20 mA output. KING-GAGE indicator correlates level to tank geometry to display actual volume amount (or weight) of liquid in tank.

Hazardous Zone Service - The downpipe sensor and pneumatic components are fully compatible with explosion hazard environments. This makes pneumatic the sensible alternative for hazardous areas without the cost and complications of intrinsic safety barriers or explosion-proof products.*

* Assumes only pneumatic components are situated in explosion hazard zone.