

Tank Top Fitting & Downpipe

Fitting Threads onto end of 3/4" pipe and suspends it from tank top. Mates to 1-1/2 NPT coupling or outlet. Distance from end of pipe to lowest point in tank should be accurately noted for indicator scaling purposes. If practical during installation, make final trim on pipe length to achieve 1-2" gap from tank bottom.

- 1-1. Pipe should standard tapered 3/4 NPT thread on one end. Check that threads are clean and not damaged.
- 1-2. Thread fitting onto end of pipe - use thread sealer to ensure leaking fit.
- 1-3. Insert pipe with fitting into tank opening. For tank connection other than 1-1/2 NPT, use bushing or adapter.

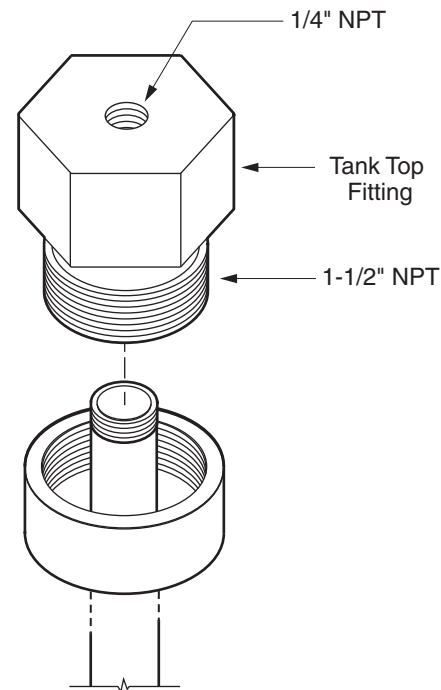

Model 735 LiquiSeal Purge Control

Recommended mounting location is close to tank at a height equal to or higher than tank top fitting/downpipe connection. A compressed air supply connection is required.

- 2-1. Mount control in the position shown. Disposable filter element should remain accessible for later replacement (recommended every 12 months). Allow adequate clearance beneath control.
- 2-2. Route compressed air supply line to control location. Installing a shut-off valve is recommended for future serving of control.

Compressed Air Supply Pressure

A sub-micron instrument grade coalescing filter should be installed upstream of the supply line to the control. Oil and/or water contamination of air supply may lead to component failure.

Minimum: 20 psi greater than anticipated liquid head pressure - or 35 psig, whichever is greater.

Maximum: Do not exceed 150 psig.

Note: If control location is subject to freezing temperatures, compressed air supply must be filtered and dry enough to prevent condensation or freeze-up in the control.

Final Tubing Connections

3/8" tubing is recommended for the air purge line to the tank top fitting/downpipe. 1/4" tubing is recommended for gauge pressure line to indicator or other receiver. Tube fittings, if supplied, correspond to tube sizes listed below. Do not "tee" into lines for any equipment that consumes air or is not specifically leaktight.

Designation	Connection	Tube Size
P - Purge	1/4 NPT	3/8" tube
G - Gauge	1/4 NPT	1/4" tube
CA - Air Supply	1/4 NPT	1/4" tube

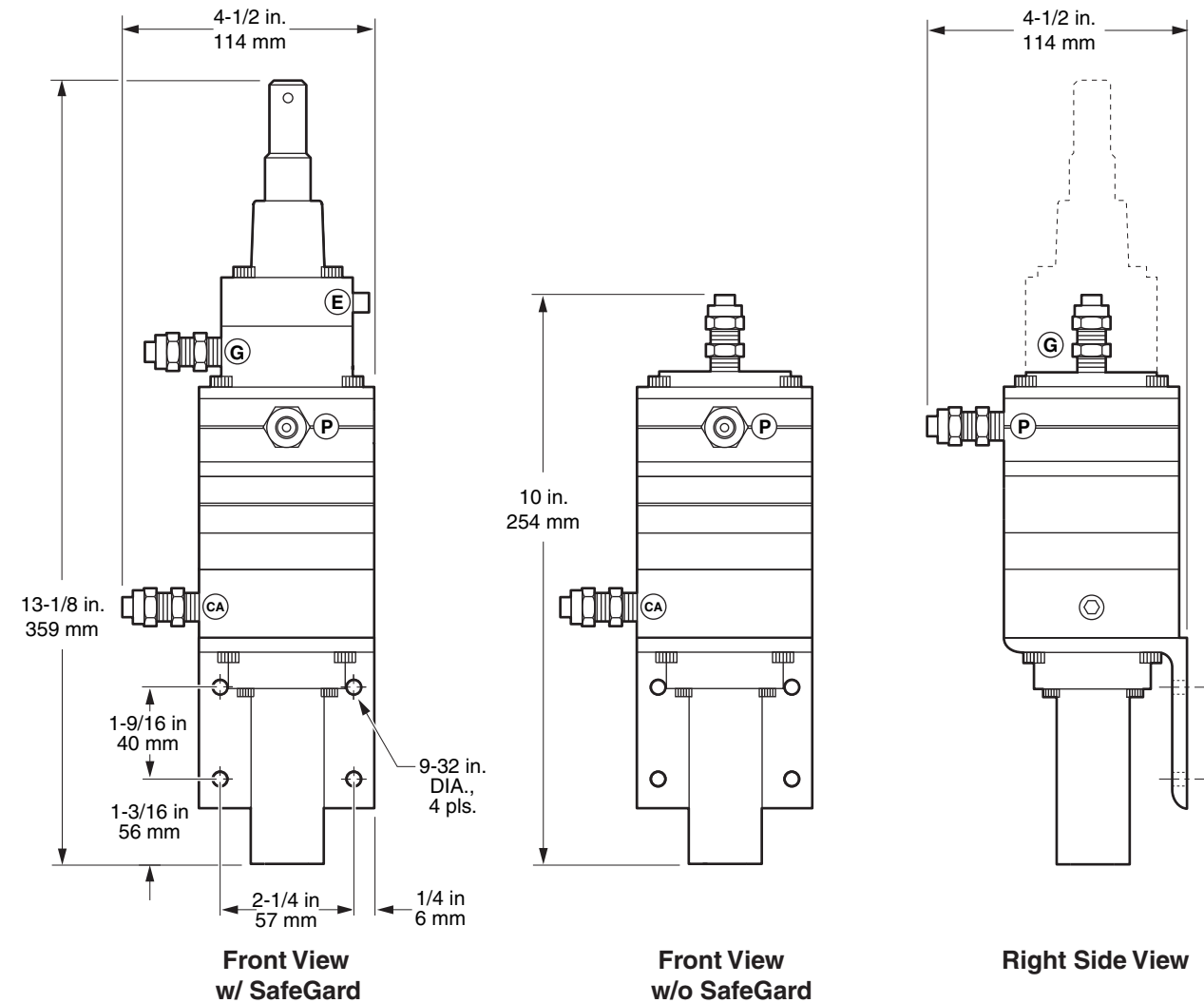
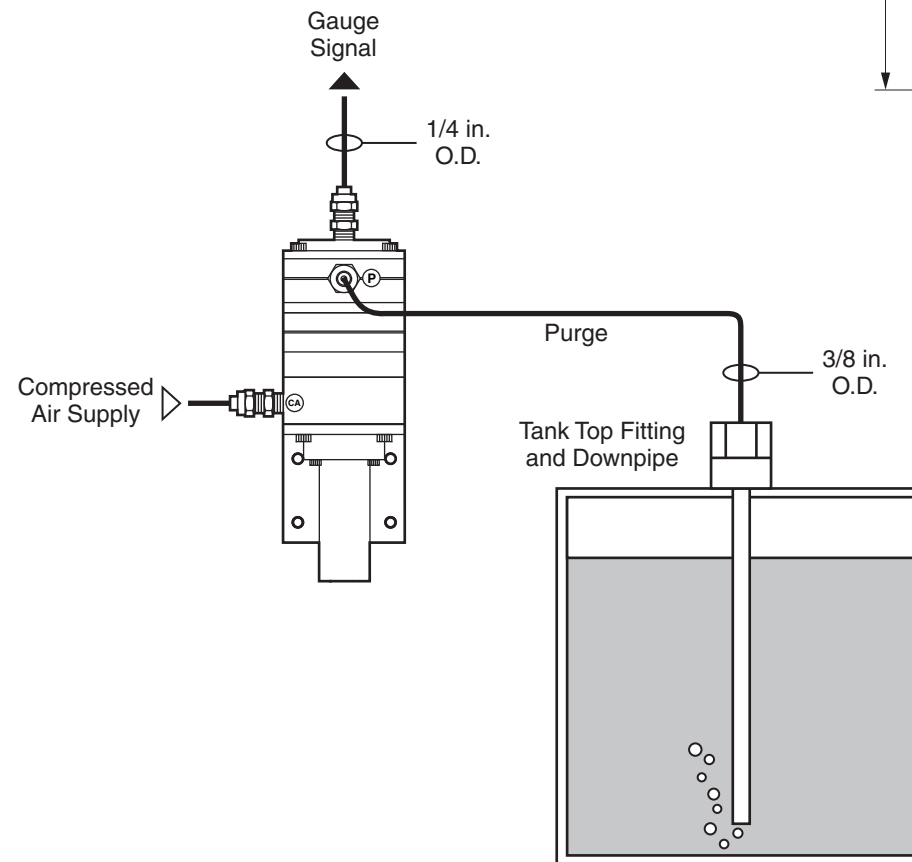

Note: Refer to instruction sheet(s) included with tank level indicator for gauge signal connections.

INSTALLATION INSTRUCTIONS

LiquiSeal Purge Control Model 735 (Air Supply and Downpipe Purge Connections)

DATE	02/21/00
DRAWN BY	M. Song
APPROVED	
A 2/00	Released

KING
ENGINEERING
CORPORATION
Box 1228, Ann Arbor, MI 48106-1228 U.S.A.
Phone: 734-662-5691 • FAX: 734-662-6652

DWG. NO.	K-1050-1-735
SHEET 1 OF 1	REV. E