

Service Parts & Dimensions – 1050-1.15

Effective: September 2014 (replaces April, 2012)

Model 738 D/P LiquiSeal Control

Part Number Reference:

738 - 918 - 1 8

Fittings:
1 - none
3 - Polyflo
4 - Swagelok

D/P Nominal Range:
0 - 5 psid
1 - 10 psid
2 - 15 psid
3 - 30 psid
4 - 50 psid

Fitting Reference:

P..... Air Purge
CA..... Compressed Air
E..... Equalizer Reference

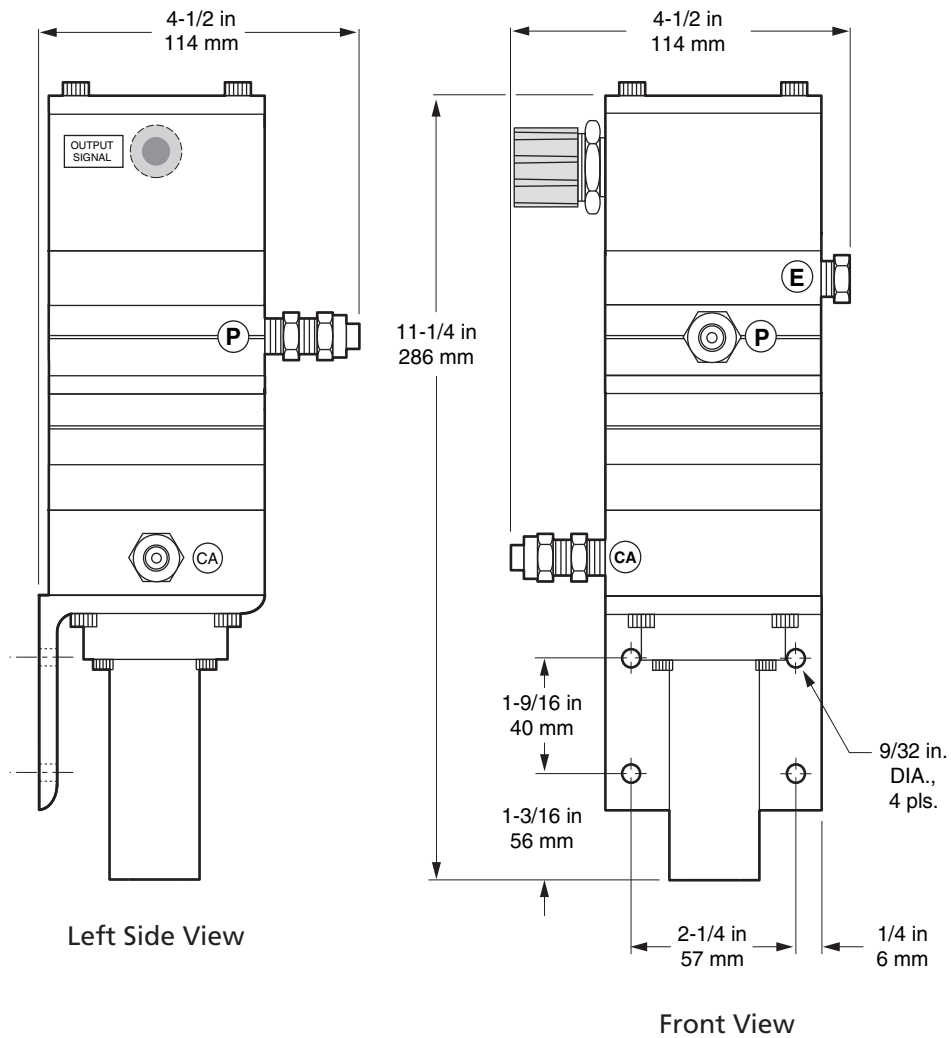

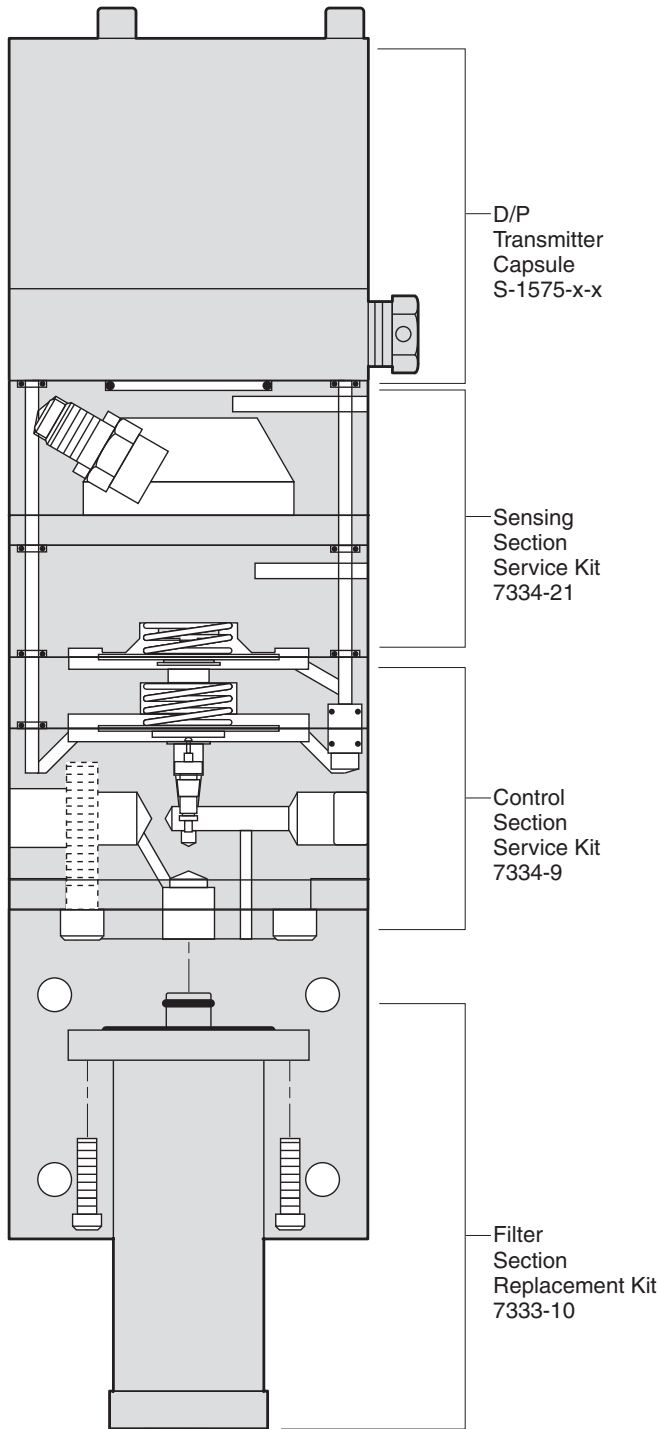

D/P Transmitter Capsule S-1575-x-x

Description	Part No.	Qty.
D/P transmitter capsule (0-5 PSID)	S-1575-0-1	*
D/P transmitter capsule (0-10 PSID)	S-1575-1-1	*
D/P transmitter capsule (0-15 PSID)	S-1575-2-1	*
D/P transmitter capsule (0-30 PSID)	S-1575-3-1	*
D/P transmitter capsule (0-50 PSID)	S-1575-4-1	*

* - Specify replacement transmitter capsule based on PSID range

Sensing Section Service Kit 7334-21

Description	Part No.	Qty.
Teflon Gasket	6438-3	1
O-Ring (large)	6495-407	1
O-Ring (small)	6495-559	6
Diaphragm Assembly	4508-5	1
Orifice Check Valve	7366-1	1

Control Section Service Kit 7334-9

Description	Part No.	Qty.
Replacement Valve Kit	3257-1	1
Orifice Assembly	4527-2	1
Diaphragm Assembly	4508-6	1
Spring (long)	6927-7	1
Diaphragm Assembly	4508-7	1
(w/ rubber seat)		
Spring (short)	6927-6	1
O-Ring	6495-559	5

Filter Section Replacement Kit 7333-10

Description	Part No.	Qty.
Filter w/ O-Rings	7333-10	1