

External TeleSensor

This type of sensor may be installed on an unused outlet on the side wall near the tank bottom or on the underside of the tank.

- Where practical, install a gate valve between the tank outlet flange and sensor to allow removal while tank is in use.
- Sensor flange is 2", 3" or 4" flat faced ANSI B.16 150-LB (gaskets and mounting hardware not included). Also available with special 3" Brewery flange (304 SS).
- Requires use of 860-series Sensor Control (or equivalent) and 35-150 psi/240-1035 kPa compressed air supply.

Installation

1. Remove plastic shipping cap inset into face of sensor flange. Avoid poking exposed diaphragm surface underneath.
2. Position sealing gasket for flange, align bolt circle of both flanges and insert bolts (not supplied).
3. Hand tighten bolts initially. Working from opposing positions around the bolt circle, tighten with adequate torque to ensure leak tight joint between the flanges.

IMPORTANT!

Gate valve is recommended to seal tank outlet in the event sensor must be serviced. Avoid use of valves that may create hydraulic pressure against sensor (e.g. globe or butterfly type valves). This may damage sensor or could create an unsafe pressure condition for removal.

Sensor Control Mounting

Refer to separate instructions for installation of the 860-series Sensor Control (or equivalent). Total length of 1/4" tubing connecting Sensor Control and TeleSensor should not exceed 50 feet. Avoid locations where Sensor Control would be exposed to freezing temperatures (< 32° F or 0° C and below).

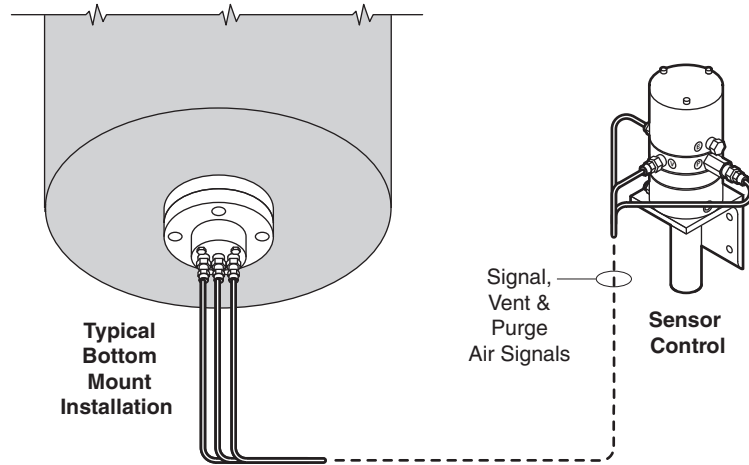
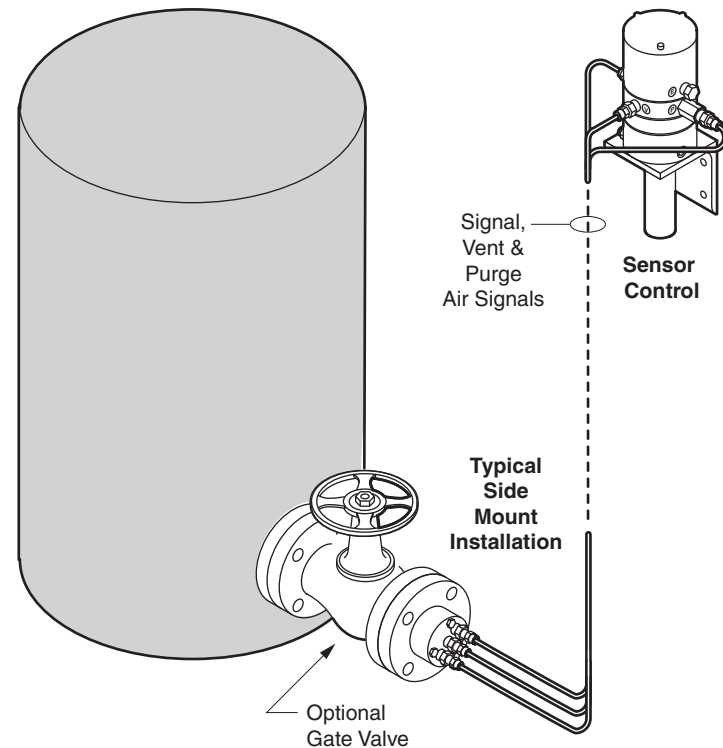

Typical Installations

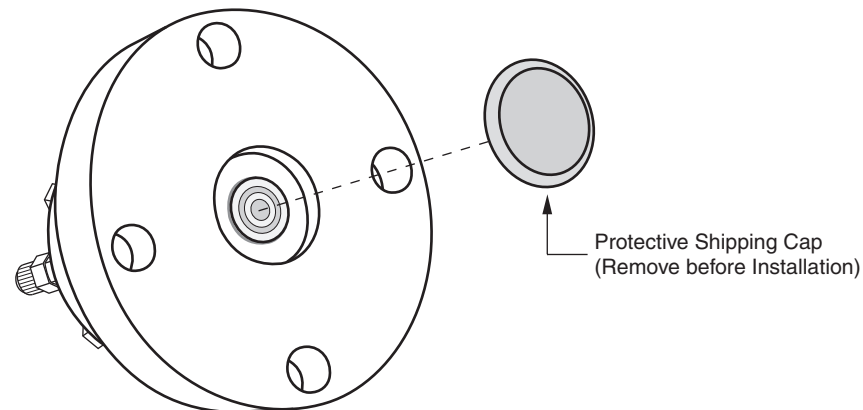

Connections - Airline Tubing

Fittings if supplied are for 1/4" tube. Three (3) separate tube lines are required to make the interconnections between Sensor Control and TeleSensor. Route tubing to avoid sharp bends or exposure to damage. Do not tee into any tube for equipment that consumes air or is not a sealed pressure device.

TeleSensor Connection Sensor Control

P (purge) connects to **P** (purge) outlet
S (signal) connects to **S** (signal) inlet
V (vent) connects to **V** (vent) inlet

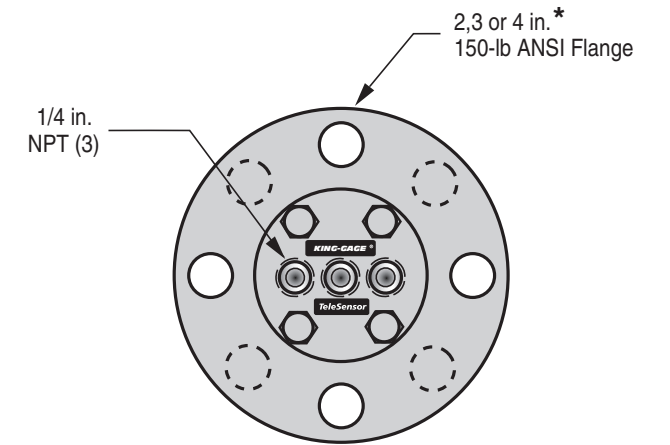
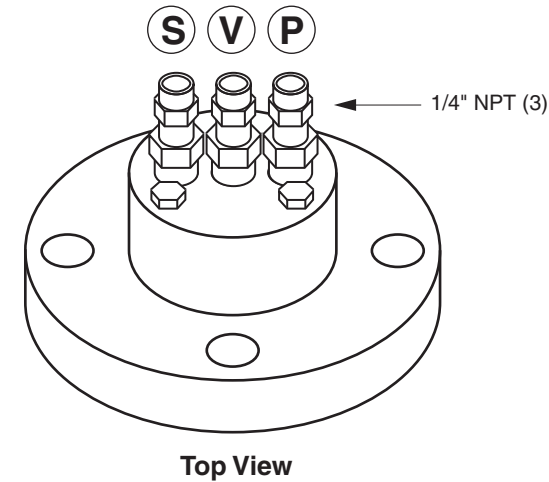

* 4 in. Flange has 8 bolt circle,
2 and 3 in. Flange have 4 bolt circle.

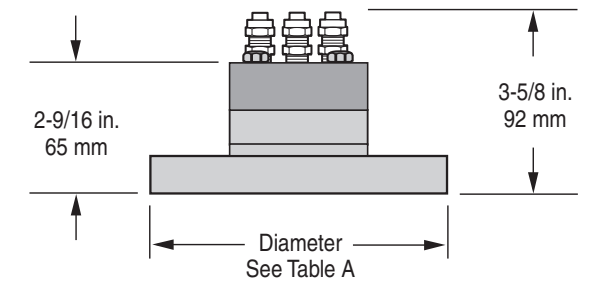

TeleSensor w/ Special
3-in. Brewery Flange (304 SS)

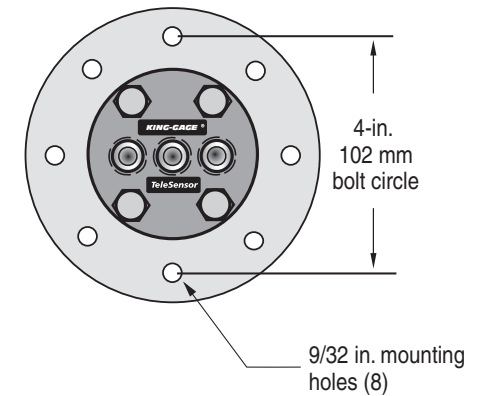

Table A - Model No. Flange Designation

Model No.	Flange Size	Diameter
922-xxx	2 in. 150-lb B.16 ANSI	6.0 in./ 153 mm
923-xxx	3 in. 150-lb B.16 ANSI	7.5 in./ 191 mm
924-xxx	4 in. 150-lb B.16 ANSI	9.0 in./ 229 mm
925-xxx	3 in. Brewery flange	5.0 in./127 mm

Reference Material -

- EX-1525-1 Troubleshooting Guide - TeleSensor Systems
 K-1090-1-860 Installation Instructions - 860 Sensor Control

		DATE	10/5/2004
C	10/05/04 Brewery Flange noted	DRAWN	Mktg Svc
B	11/22/02 Added Table A	APP'D	<i>JL</i>

INSTALLATION INSTRUCTIONS

External Mount TeleSensor

KING-GAGE
A NOSHOK Company

1010 West Bagley Rd., Berea, Ohio 44017
Ph 855.367.2494 www.king-gage.com

DWG NO.
K-1020-1-922

SHEET
1 OF **1**

REV.
C