

Air-Guard Dual Stage Filter 60 SCFM

9460 SERIES



- Designed for main supply line applications where pipe scale, residual oil aerosols, and condensation can degrade air quality
- Dual cartridge design provides long service life
- Supplied with KING Type 750/800 element set that includes coalescing scrubber and adsorptive polisher cartridges, Type 300/300 element set is optional

SPECIFICATIONS

Maximum pressure	150 psi
Rated flow	60 scfm @ 100 psig; 1699 l/min @ 7 Kg/cm ² ; 102 m ³ /hr @ 7 bar
Connections	1" NPT
Filter type	Dual cartridge coalescing elements
Housing	Aluminum
Sump	Aluminum
Efficiency	99.998% @ 0.1 micron
Weight	25.0 lb/11.3 kg

APPLICATIONS

- Main supply line applications where pipe scale, residual oil aerosols, and condensation can degrade air quality



ORDERING INFORMATION		
SERIES	9460 Air-Guard Dual Stage Filter 60 SCFM	
DRAIN TYPE	3 With manual drain	3T With auto drain
EFFICIENCY	6-5 99.998% @ 0.1 micron	1-1 98% @ 2.0 micron

EXAMPLE

Series9460 Series
 Drain type With auto drain
 Efficiency 98% @ 2.0 micron

9460 - 3T - 1-1

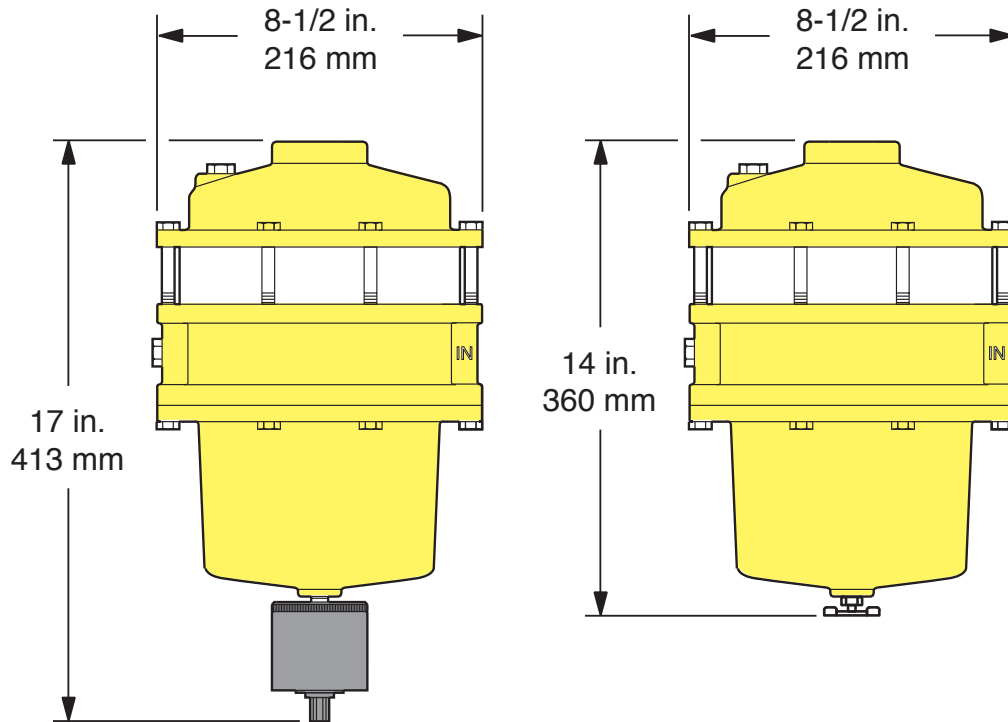

Replacement Cartridge Sets
22-31-6-5 - Type 750/800 (0.1 micron)
22-31-1-1 - Type 300/300 (2.0 micron)